

JT820

Parts Manual

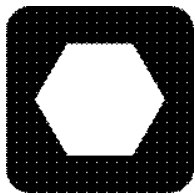

Ditch Witch[®]

JT820

ISSUE NO. 09PL-08/11

For Replacement Copy Order **P/N 053-435**

This product is covered by one or more of the following patents:

US B1 4,858,704; 4,953,638; 5,148,880; 5,242,026; 5,341,887; 5,490,569; 5,684,466; 5,713,423, 5,794,719; 5,880,680; 5,941,322; 6,085,852; 6,109,371; 6,179,065; 6,216,803; 6,250,403; 6,250,404; 6,290,606; 6,311,790; 6,411,094; 6,543,551; 6,550,547; 6,672,409; 6,739,413; 6,776,246; 6,808,210; 6,827,158; RE37,450; RE37,923; RE37,975; RE38,418

AU 689,533; 706,544; 718,034, 755,862

CA 2,156,398

FR 674,093

DE 694 17 019; 695 29 634; 297 01 406

EP 0683845; 0674093; 0817901; 0846841

GB 2,209,239; 2,312,006; EP674,093; EP846,841

JP 3,458,247

Other U.S. and foreign patents pending

This manual contains information concerning the following models:
JT820 Directional Drilling System

Copyright 1996, 2011 by The Charles Machine Works, Inc.

 , Ditch Witch, CMW, AutoCrowd, Modularmatic, Jet Trac, Roto Witch, Subsite, Fluid Miser, Perma-Soil, Power Pipe, Super Witch, Super Witch II, Pierce Arrow, The Underground, and The Underground Authority Worldwide are registered trademarks of The Charles Machine Works, Inc.

ID0040795

FOREWORD

This manual contains illustrated parts lists to help you select quality ProTech[®] Replacement parts for your Ditch Witch[®] equipment. Using other replacement parts will lessen the productivity of your equipment.

- ◆ Part numbers enclosed in a box are no longer available from The Charles Machine Works, Inc. Your local Ditch Witch dealer may be able to locate the part for you.
- ◆ Footnotes provide more information to help you identify parts shown in the manual.
- ◆ Assembly instructions and Tech Bits articles referenced in footnotes are available through your local Ditch Witch dealer.
- ◆ Description and specifications in this book were current at publication. However, The Charles Machine Works, Inc. reserves the right to improve equipment, so this manual might not reflect the most current improvements.
- ◆ Instructions on recommended equipment use and maintenance are in the Operator's Manual that was shipped with your equipment.

Keep the following in mind when ordering ProTech replacement parts:

- ◆ Specify parts you need by part number and description, not by illustration reference numbers.
- ◆ Have equipment model and serial number on hand to help ensure you get the right parts for your machine whether it's old or new.

Thank you for buying and using Ditch Witch equipment and ProTech replacement parts.

WARRANTY

DW WARRANTY Policy
July, 2005

POLICY 1: DITCH WITCH® EQUIPMENT AND REPLACEMENT PARTS LIMITED WARRANTY POLICY

Subject to the limitation and exclusions herein, free replacement parts will be provided at any authorized Ditch Witch dealership for any Ditch Witch equipment or parts manufactured by The Charles Machine Works, Inc. (CMW) that fail due to a defect in material or workmanship within one (1) year of first commercial use (Exception: 2 years for all SK500 Attachments). Free labor will be provided at any authorized Ditch Witch dealership for installation of parts under this warranty during the first year following "initial commercial" use of the serial numbered Ditch Witch equipment on which it is installed. The customer is responsible for transporting their equipment to an authorized Ditch Witch dealership for all warranty work.

EXCLUSIONS FROM PRODUCT WARRANTY

- All incidental or consequential damages.
- All defects, damages, or injuries caused by misuse, abuse, improper installation, alteration, neglect, or uses other than those for which products were intended.
- All defects, damages, or injuries caused by improper training, operation, or servicing of products in a manner inconsistent with manufacturer's recommendations.
- All engines and engine accessories (these are covered by original manufacturer's warranty).
- Tires, belts, and other parts which are subject to another manufacturer's warranty. (Such warranty will be available to purchaser.)
- ALL IMPLIED WARRANTIES NOT EXPRESSLY STATED HEREIN, INCLUDING ANY WARRANTY OF FITNESS FOR A PARTICULAR PURPOSE AND MERCHANTABILITY.

IF THE PRODUCTS ARE PURCHASED FOR COMMERCIAL PURPOSES, AS DEFINED BY THE UNIFORM COMMERCIAL CODE, THEN THERE ARE NO WARRANTIES WHICH EXTEND BEYOND THE FACE HEREOF AND THERE ARE NO IMPLIED WARRANTIES OF ANY KIND WHICH EXTEND TO A COMMERCIAL BUYER. ALL OTHER PROVISIONS OF THIS LIMITED WARRANTY APPLY INCLUDING THE DUTIES IMPOSED.

Ditch Witch products have been tested to deliver acceptable performance in most conditions. This does not imply they will deliver acceptable performance in all conditions. Therefore, to assure suitability, products should be operated under anticipated working conditions prior to purchase.

Defects will be determined by an inspection within thirty (30) days of the date of failure of the product or part by CMW or its authorized dealer. CMW will provide the location of its inspection facilities or it's nearest authorized dealer upon inquiry. CMW reserves the right to supply remanufactured replacement parts under this warranty as it deems appropriate.

Extended warranties are available upon request from your local Ditch Witch dealer or CMW.

Some states do not allow exclusion or limitation of incidental or consequential damages, so the above limitation or exclusion may not apply. Further, some states do not allow exclusion of or limitation of how long an implied warranty lasts, so the above limitation may not apply. This limited warranty gives product owner specific legal rights and the product owner may also have other rights which vary from state to state.

For information regarding this limited warranty, contact CMW's Product Support Department, P.O. Box 66, Perry, OK 73077-0066, or contact your local Ditch Witch dealer.

CONTENTS

Decals

Decal Location - JT820	8
------------------------------	---

Frame Components

Carriage	18
Chain Tensioner	24
Covers/Guards	46
Cylinder Grease	32
Drill Frame	14
Front Wrench	16
Fuel Tank/Hydraulic Reservoir	44
Idler	34
Mud Mixing System	40
Output Shaft	20
Rear Stabilizer	42
Roller	36
Seat Mount	48
Shift Lever	22
Spring	30
Track Group - Rubber	26
Track Group - Steel	28
Water Tank Support	38

Engine Components

Air Filter System	60
Alternator	56
Engine	52
Fuel Filter	58
Radiator	62
Throttle	54

Hydraulic

Anchor Driver Hydraulics	90
Break-out Hydraulics - Begins	98
Break-out Hydraulics - Ends	96
Carriage Thrust Hydraulics	92
Control Valves/Lever	80
Drive Control Valve/Lever	78
Flow Divider.....	110
Frame Tilt	88
Ground Drive Hydraulics	82
Hydraulic Cylinder (2.0"X1.0"X10.0")	130
Hydraulic Cylinder (3.0"X1.5"X4.0")	128
Hydraulic Cylinder (3.0"X1.5"X20.0")	132
Hydraulic Motor - Rotation	134
Hydraulic Oil Cooler	76
Hydraulic Reservoir	74
Hydraulic Schematic - Begins	70
Hydraulic Schematic - Ends	66
Mud Motor Hydraulics - Begins	104
Mud Motor Hydraulics - Ends.....	106
Mud Pump Plumbing	126
Mud Tank Plumbing	120
Pump Hydraulics	114
Pump Hydraulics - Begins	112

Pump Hydraulics - w/o Water Tank	116
Rotation Hydraulics	94
Stabilizer	86
Supply Hydraulics	108
Track Extend Hydraulics	84
Water Motor Hydraulics - Begins	100
Water Motor Hydraulics - Ends	102
Water Pump.....	124
Water Pump Plumbing	122
Water Tank Plumbing	118

Electrical

Console Gauges	142
Electrical Diagram - Engine/Frame	148
Electrical Diagram - Gauge Harness	154
Electrical Diagram - Operator Console	152
Electrical Schematic	156
Electrical Strike System	138
Ground Cables	140
Operators Station Gauges	144
Relay Panel	146

Options

2-Point Anchor Parts	172
4-Point Anchor System	174
Anchor Extension	176
Anchoring Hydraulics Heavy Duty	162
Anchoring Parts	170
Curb Stakes	178
Drill Pipe Accessories	182
EZ-Connect.....	184
Hydraulic Motor	164
Hydraulic Stake Driver	168
Mud Mixing Accessories	188
Soil Sampler	192
Transmitter Housing	166
Wash Wand	186
Water Transfer System	180
Working Light.....	190

Miscellaneous

Bolt/Nut Torque Chart.....	196
Parts Manual Change Request.....	201
Replacement O-Ring Chart	199
Warranty Registration	204

DECALS

DECAL KIT JT820

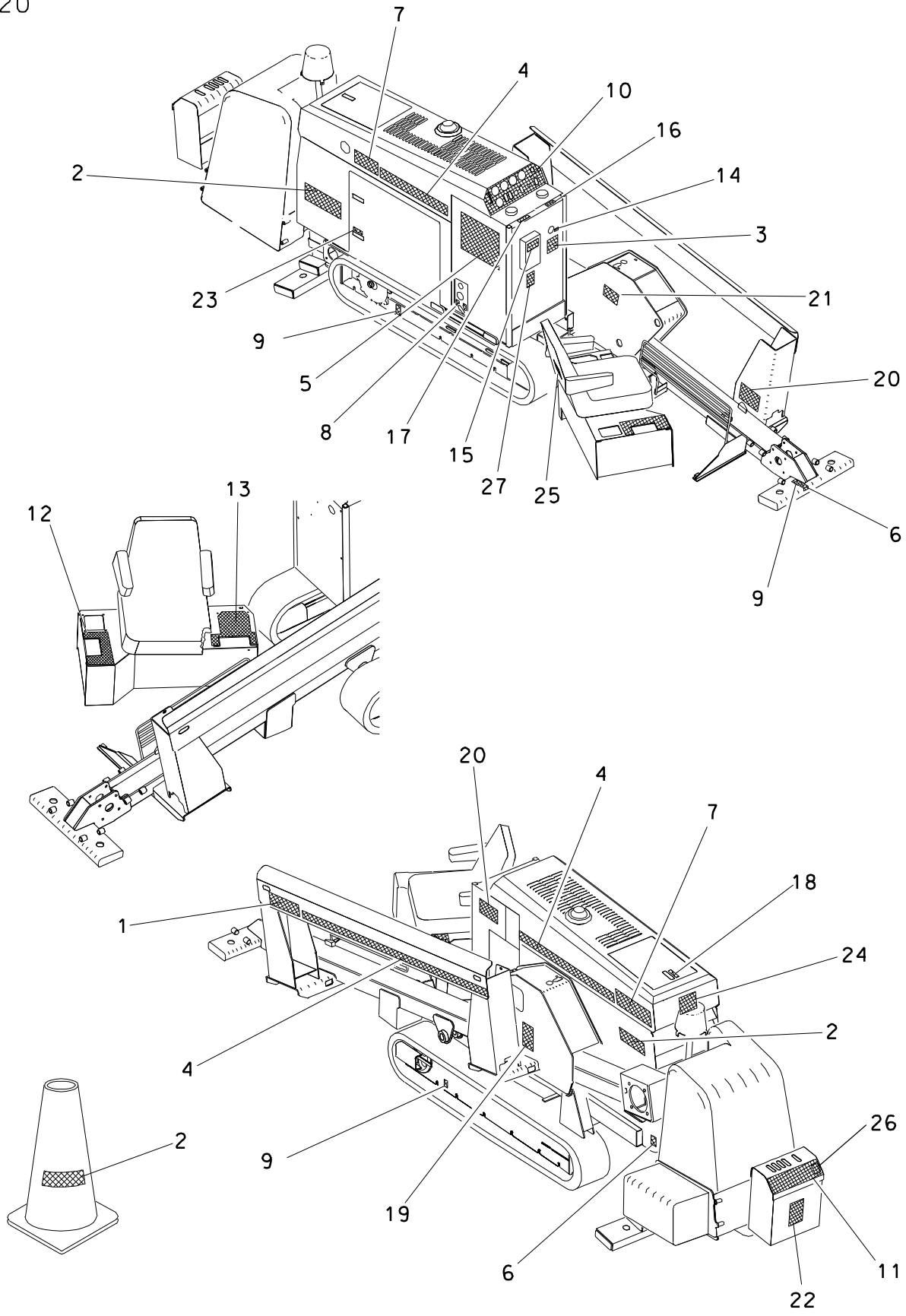

DECAL KIT JT820

REF NO.	PART NUMBER	QTY	DESCRIPTION	REMARKS
	275-659		DECAL KIT	
	803-104	1	DECAL LOCATION PAGE	
1.	274-024	1	DITCH WITCH LOGOTYPE	
2.	274-049	10	DANGER, ELECTROCUTION	8 REQ'D FOR TRAFFIC CONES
3.	274-050	1	DANGER, UNDERGROUND	
4.	274-247	A/R	ACCENT STRIPE	USE 126.00"
5.	274-312	1	DITCH WITCH LOGOTYPE	
6.	274-318	3	TIE DOWN	
7.	274-346	2	JT820 MODEL IDENTIFIER	
8.	274-375	1	MASTER DISCONNECT SWITCH	
9.	274-442	3	LIFT LOCATION	
10.	274-499	1	INSTRUMENT PANEL	
11.	274-500	1	SET-UP CONTROL PANEL	
12.	274-503	1	BORE CONTROL PANEL	
13.	274-593	1	LEFT CONTROL PANEL	
14.	275-023	1	OIL LEVEL	
15.	275-048	1	IMPORTANT, SAFETY RULES	
16.	275-120	1	RESERVOIR	
17.	275-148	1	FUEL TANK	DIESEL
18.	275-149	1	RADIATOR	COOLANT
19.	275-184	1	WARNING, MOVING PARTS	
20.	275-197	2	DANGER, ROTATING SHAFT	
21.	275-341	1	WARNING, SLIDING PARTS	
22.	275-383	1	NOTICE, SLOPE PARKING	
23.	275-400	1	NOTICE, OIL LEVEL	
24.	275-449	1	DITCH WITCH LOGO	
25.	275-450	1	DITCH WITCH LOGO	
26.	274-724	1	NO DIG	
27.	274-780	1	APPLICABLE PATENT(S)	

FOOTNOTES

DECAL KIT JT820

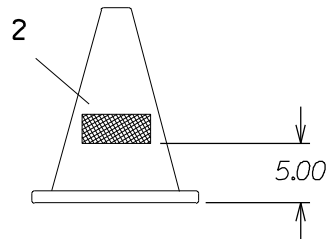
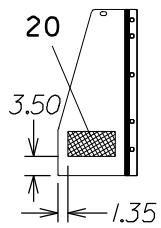
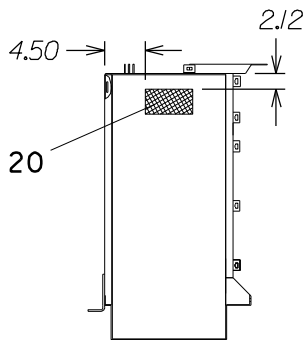
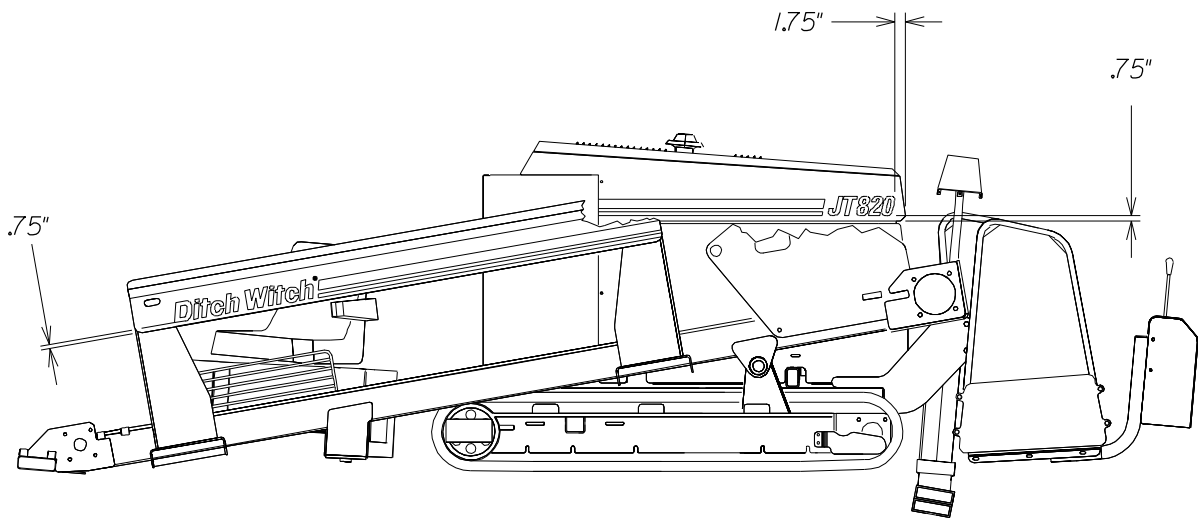
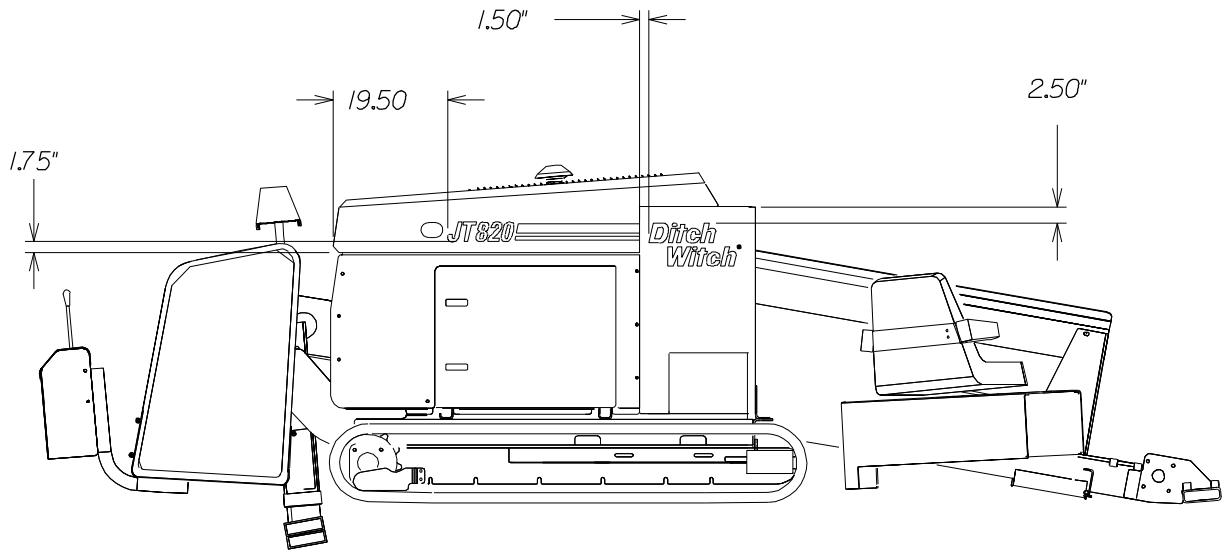

FRAME COMPONENTS

DRILL FRAME COMPONENTS

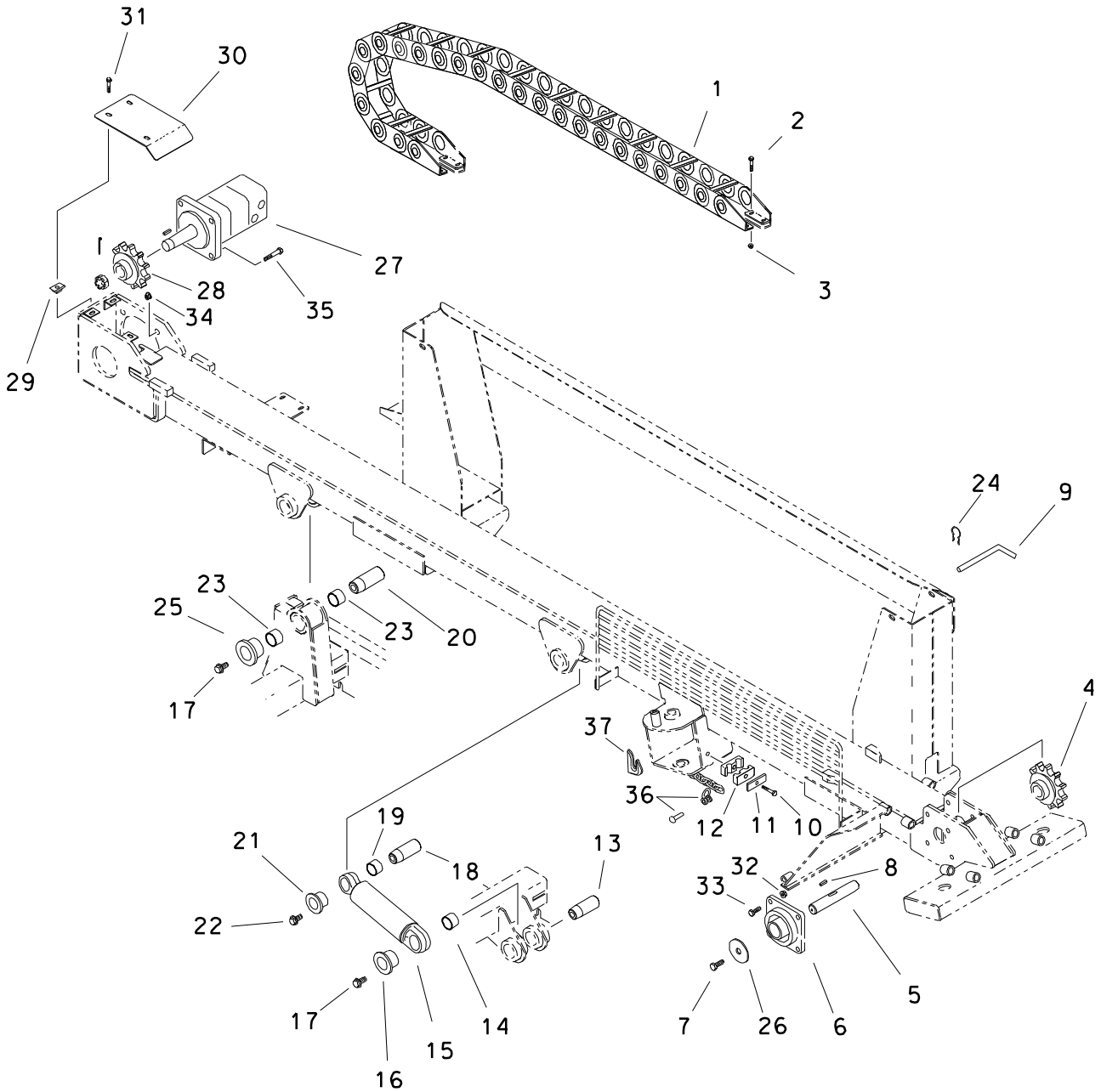

DRILL FRAME COMPONENTS

REF NO.	PART NUMBER	QTY	DESCRIPTION	REMARKS
1.	353-606	1	CABLE CARRIER	
	359-944	AR	EASY OUT BAR (1/2"OD X 4.00")	
	359-945	AR	ALUMINUM BAR (1/2"OD X 4.00")	
	359-947	AR	16" REPAIR SECTION	
2.	105-823	8	FLG LK BOLT (5/16-NC X 3/4")	
3.	105-003	8	FLG LOCKNUT (5/16-NC)	
4.	175-645	1	SPROCKET (100B11T)	
5.	183-843	1	ROLER PIN	
6.	125-614	2	FLANGE BEARING (1-5/8")	
7.	106-079	1	SCREW (M10-1.50 X 30MM)	
8.	165-963	1	KEY (3/8" X 1-1/8")	
9.	184-711	2	PIN	
10.	105-883	2	FLG LK BOLT (3/8-NC X 2")	
11.	305-256	2	BACK-UP SPACER	
12.	110-270	4	CLAMP (9/16")	
13.	179-033	1	TAPERED PIN	
14.	125-773	1	COMPOSITION BUSHING	
15.	151-054	1	CYL (3.0" X 1.500" X 4.000")	
16.	181-975	1	TAPERED INSERT (1.500")	
17.	105-998	2	SCREW (M16-2 X 40MM)	
18.	179-078	1	TAPERED PIN	
19.	125-772	1	COMPOSITION BUSHING	
20.	179-037	1	TAPERED PIN (1.750" X 5.200")	
21.	181-974	1	TAPERED INSERT (1.500")	
22.	105-969	1	FLG BOLT (5/8-NC X 1-1/2")	
23.	125-700	2	COMPOSITION BUSHING	
24.	110-033	2	SPRING CLIP PIN (1/8" X 1/2")	
25.	181-975	1	TAPERED INSERT (1.750")	
26.	105-223	1	WASHER (3/8")	
27.	158-795	1	HYDRAULIC MOTOR	SEE FOOTNOTE 1
	190-621	1	SEAL REPAIR KIT	
	190-728	1	SEAL REPAIR KIT	
28.	175-545	1	MACHINED REAR SPROCKET (100B11T)	
29.	106-551	3	CLIP NUT (M8-1.25)	
30.	353-138	1	COVER PLATE	
31.	106-381	3	FLG LK SCREW (M8-1.25 X 25MM)	
32.	106-089	8	NUT M12-1.75	
33.	105-247	8	SCREW (M12-1.75 X 35MM)	
34.	105-357	4	LOCKNUT (5/8-NC)	
35.	105-462	4	BOLT (5/8-NC X 2-1/4")	
36.	110-289	2	ANCHOR SHACKLE (5/16")	
37.	110-059	1	GRAB HOOK (1/4")	

FOOTNOTES

1. TORQUE HYDRAULIC MOTOR TO 475 N-M (350FT-LBS)

FRONT WRENCH

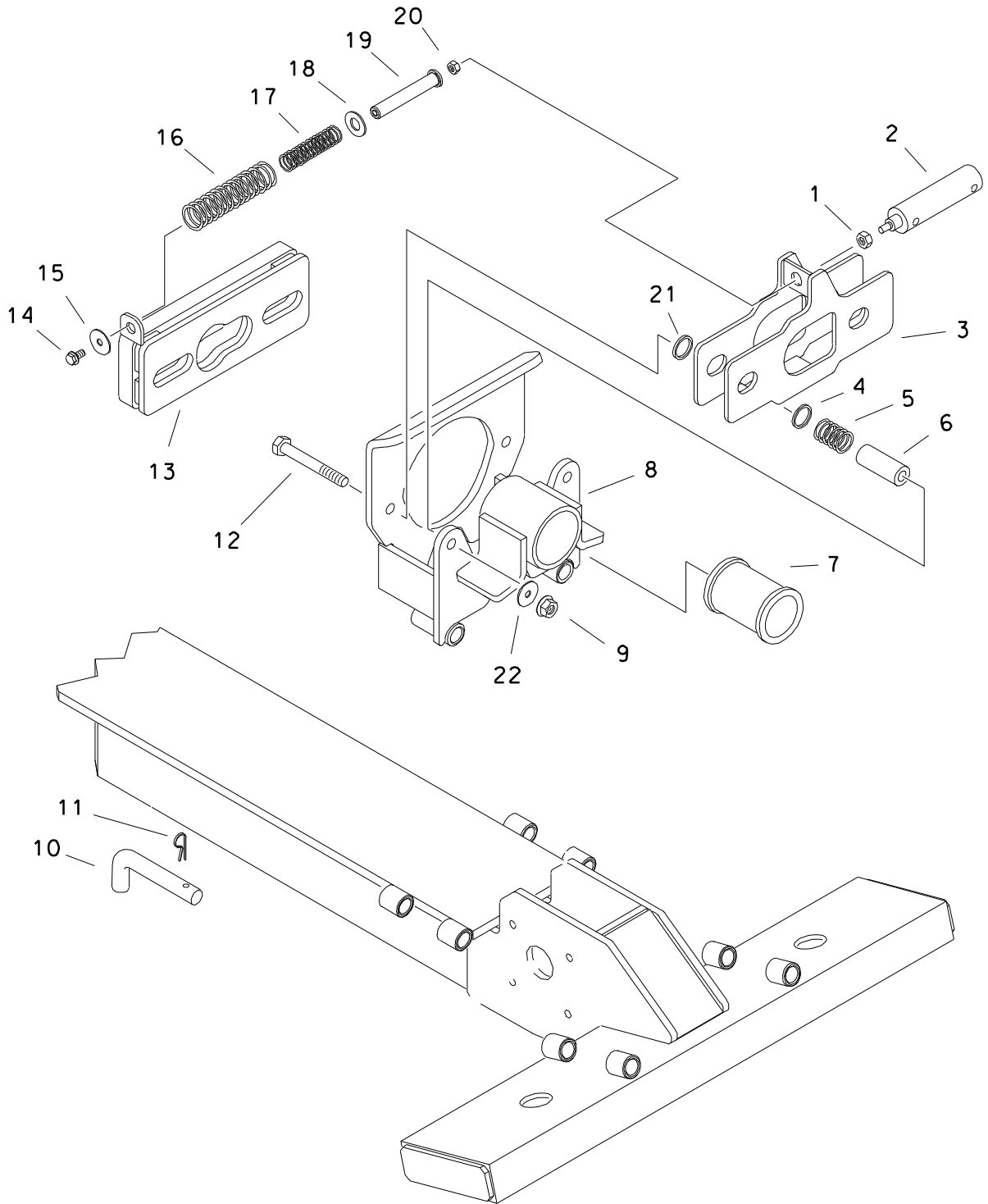

FRONT WRENCH

REF NO.	PART NUMBER	QTY	DESCRIPTION	REMARKS
1.	105-404	1	JAM NUT (3/4-NF)	
2.	151-097	1	CYLINDER (1.5" X 0.43" X 2.500")	
3.	353-633	1	SLIDE PLATE	
4.	110-058	2	MACHINERY BUSHING (18 GA X 1")	
5.	117-017	2	COMPRESSION SPRING	
6.	183-966	2	BUSHING	
7.	184-537	1	ROD BUSHING GUIDE	
8.	353-636	1	FRONT WRENCH MOUNT	
9.	106-031	2	LCK NUT (M12-1.75)	
10.	183-818	4	PIN	
11.	110-033	4	SPRING CLIP PIN (1/8" X 1/2")	
12.	106-618	2	SCREW (M12-1.75 X 130 MM)	
13.	353-632	1	WRENCH PLATE	
14.	105-823	1	FLG LK BOLT (5/16-NC X 3/4")	
15.	106-260	1	WASHER (3/8")	
16.	115-591	1	COMPRESSION SPRING	
17.	115-576	1	COMPRESSION SPRING	
18.	355-607	1	WASHER	
19.	358-294	1	SPRING GUIDE	
20.	105-920	1	JAM LOCKNUT (7/16-NF)	
21.	110-078	2	MACHINERY BUSHING (14 GA X 1")	
22.	106-397	2	WASHER (M12)	

FOOTNOTES

CARRIAGE

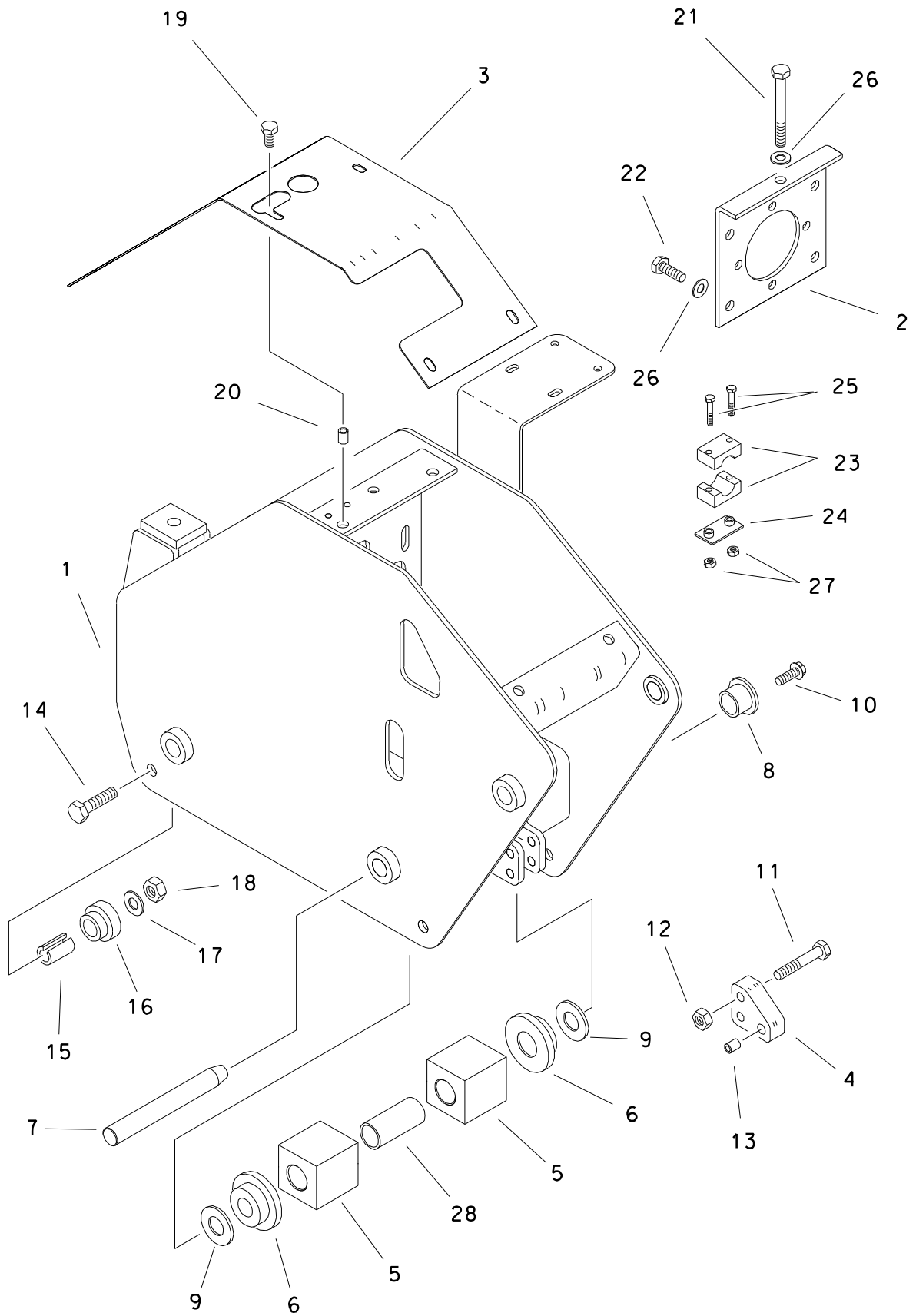

CARRIAGE

REF NO.	PART NUMBER	QTY	DESCRIPTION	REMARKS
1.	353-601	1	CARRIAGE	
2.	353-603	1	MOTOR BRACKET	
3.	353-654	1	TOP COVER	
4.	355-455	1	THRUST CHAIN CONNECTOR	
5.	355-617	4	CARRIAGE SLIDE	
6.	105-916	4	WASHER-CARRIAGE GUIDE	
7.	183-921	2	TAPERED PIN	
8.	181-981	2	TAPERED INSERT (1.000")	
9.	110-058	AR	MACHINERY BUSHING (1" X 18 GA)	
	110-078	AR	MACHINERY BUSHING (14 GA X 1")	
10.	106-079	2	SCREW (M10-1.5 X 30MM)	
11.	106-594	2	SCREW (M12-1.75 X 60MM)	
12.	106-031	2	LOCKNUT (M12-1.75)	
13.	130-323	2	ROLLER BUSHING (#100)	
14.	106-666	4	SCREW (M16-2.00 X 65MM 10.9)	
15.	355-622	4	BEARING MOUNT CAM	
16.	125-003	4	BALL BEARING	
17.	106-398	4	WASHER (M16, HARDENED)	
18.	106-545	4	LOCKNUT (M16-2.00)	
19.	105-274	6	SCREW (M10-1.5 X 20MM)	
20.	106-550	6	NUTSERT (M10-1.50)	
21.	106-337	1	SCREW (M12-1.75 X 110MM)	
22.	105-247	4	SCREW (M12-1.75 X 35MM)	
23.	110-411	1	CLAMP (3/4")	
24.	322-289	1	TOP PLATE	
25.	105-224	2	BOLT (7/16 - NC X 1", ALN HD)	
26.	106-391	5	WASHER (M12)	
27.	105-832	2	LOCKNUT (1/2 - NC)	
28.	355-588	2	BUSHING	

FOOTNOTES

OUTPUT SHAFT

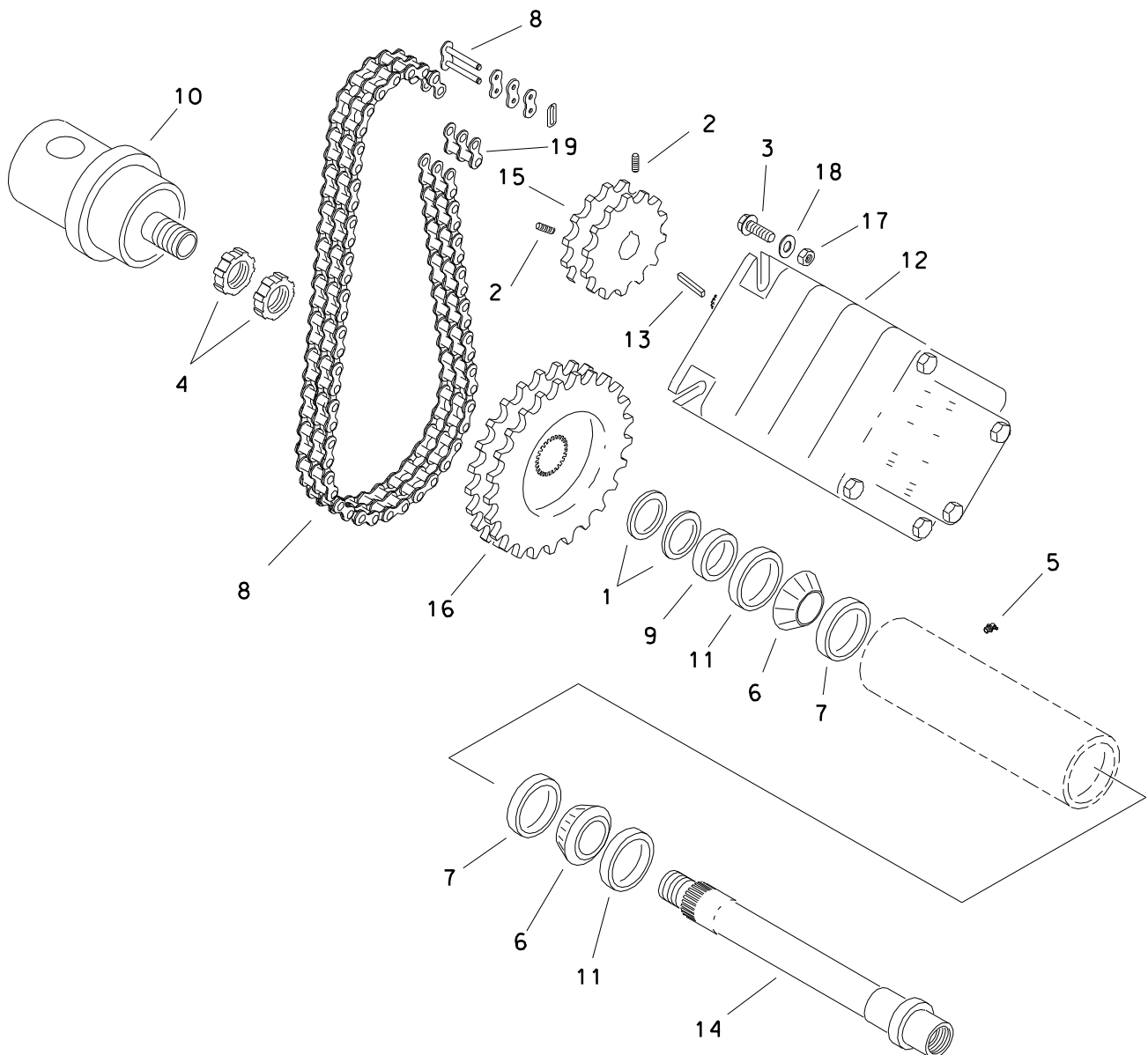

OUTPUT SHAFT

REF NO.	PART NUMBER	QTY	DESCRIPTION	REMARKS
1.	501-125	2	MACHINERY BUSHING	
2.	105-708	2	SET SCREW (3/8-NC X 3/8", NYLOK)	
3.	106-334	4	SCREW (M12-1.75 X 50MM)	
4.	106-104	2	NUT (1-1/2-NEF)	
5.	115-006	1	ZERK (1/4-NF, 45)	
6.	125-269	2	TAPERED ROLLER BEARING	
7.	125-270	2	BEARING RACE	
8.	130-238	1	ROLLER CHAIN (#60-2, 34P)	
	130-209	1	CONNECTOR LINK (#60-2)	
9.	181-641	1	SEAL RING	
10.	159-240	1	WATER SWIVEL	
	500-836	1	PACKING/SEAL KIT	
11.	155-887	2	INTERNAL SEAL	
12.	158-724	1	HYD ROTATION MOTOR	
13.	165-916	1	KEY (5/16-SQ X 1-3/4")	
14.	167-155	1	OUTPUT SHAFT	
15.	175-490	1	SPROCKET (60-2 14T)	
16.	176-406	1	SPROCKET (60-2 23T)	
17.	106-354	4	NUT (M12-1.75)	
18.	106-391	4	WASHER (M12, UNHARDENED)	
19.	130-207	1	DOUBLE OFFSET LINK (#60-2)	

FOOTNOTES

SHIFT LEVER

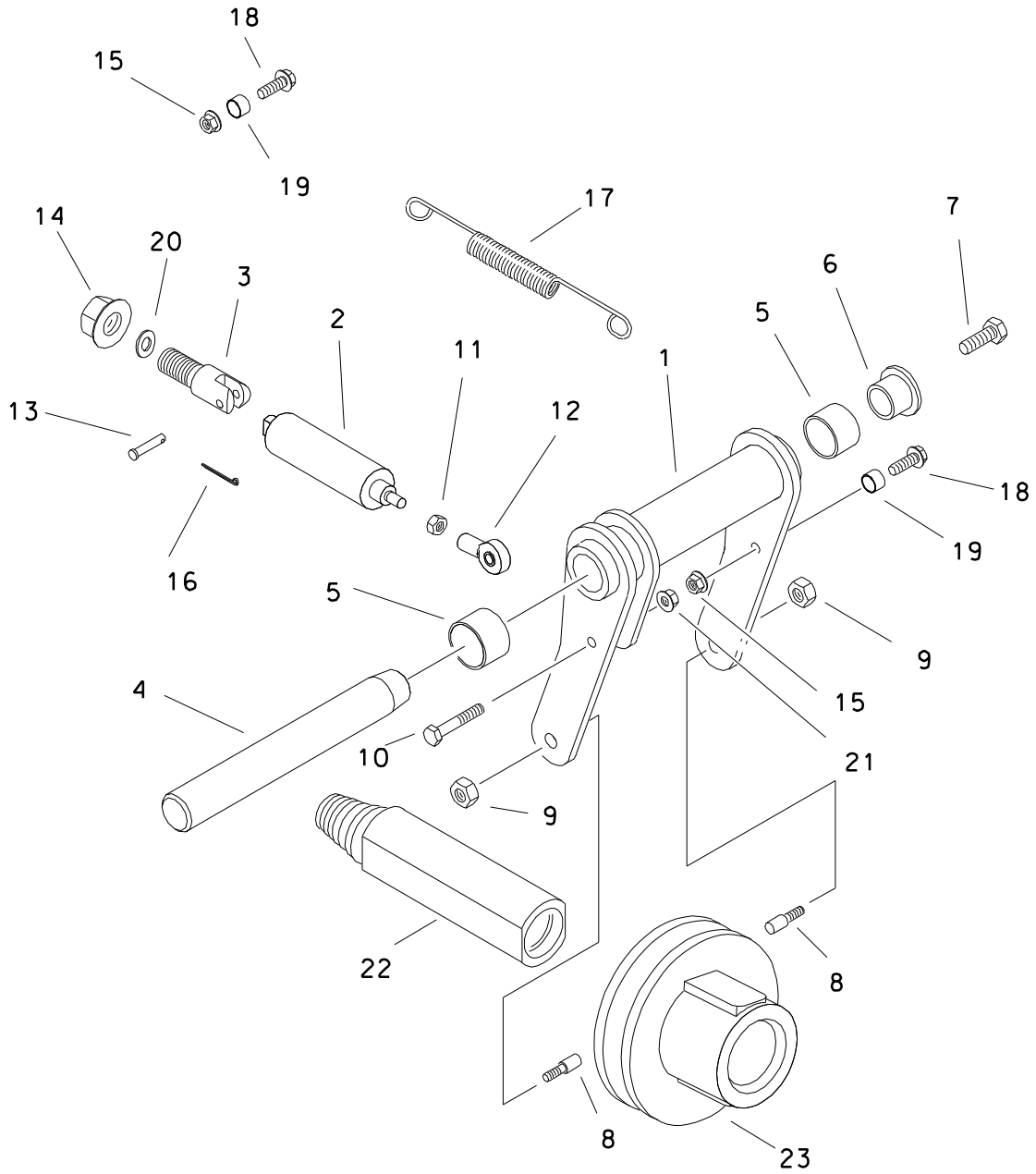

SHIFT LEVER

REF NO.	PART NUMBER	QTY	DESCRIPTION	REMARKS
1.	353-602	1	SHIFT FORK	
2.	151-075	1	CYL (1.1" X 0.312" X 1.000")	
3.	355-457	1	CYLINDER MOUNT CLEVIS	
4.	183-921	1	TAPERED PIN (25.4MM X 215.7MM)	
5.	125-770	2	COMPOSITION BUSHING	
6.	181-981	1	TAPERED INSERT (1.000")	
7.	106-079	1	SCREW (M10-1.5 X 30MM)	
8.	183-998	2	SHIFT PIN	
9.	105-151	2	LOCKNUT (7/16-NC)	
10.	106-329	1	SCREW (M8-1.25 X 50MM)	
11.	105-115	1	JAM NUT (5/16-NF)	
12.	110-575	1	ROD END (5/16-NF, FM)	
13.	500-059	1	LEVER PIN	
14.	106-545	1	LCKNUT (M16-2.0)	
15.	106-386	2	FLG LK NUT (M8-1.25)	
16.	105-530	1	COTTER PIN (1/16" X 3/4")	
17.	117-044	1	EXTENSION SPRING	
18.	106-381	2	FLG LK SCREW (M8-1.25 X 25MM)	
19.	181-723	2	BUSHING	
20.	106-398	2	WASHER (M16, HARDENED)	
21.	106-078	2	HEX NUT (M8-1.25)	
22.	353-764	1	SLIDE MOUNT	SEE FOOTNOTE 1
23.	353-763	1	WRENCH COLLAR	

FOOTNOTES

APPLY 680 LOCTITE TO MALE THREADS ON 353-764 (SLIDE MOUNT). TORQUE TO 1627 N-M (1200 FT-LBS)

CHAIN TENSIONER

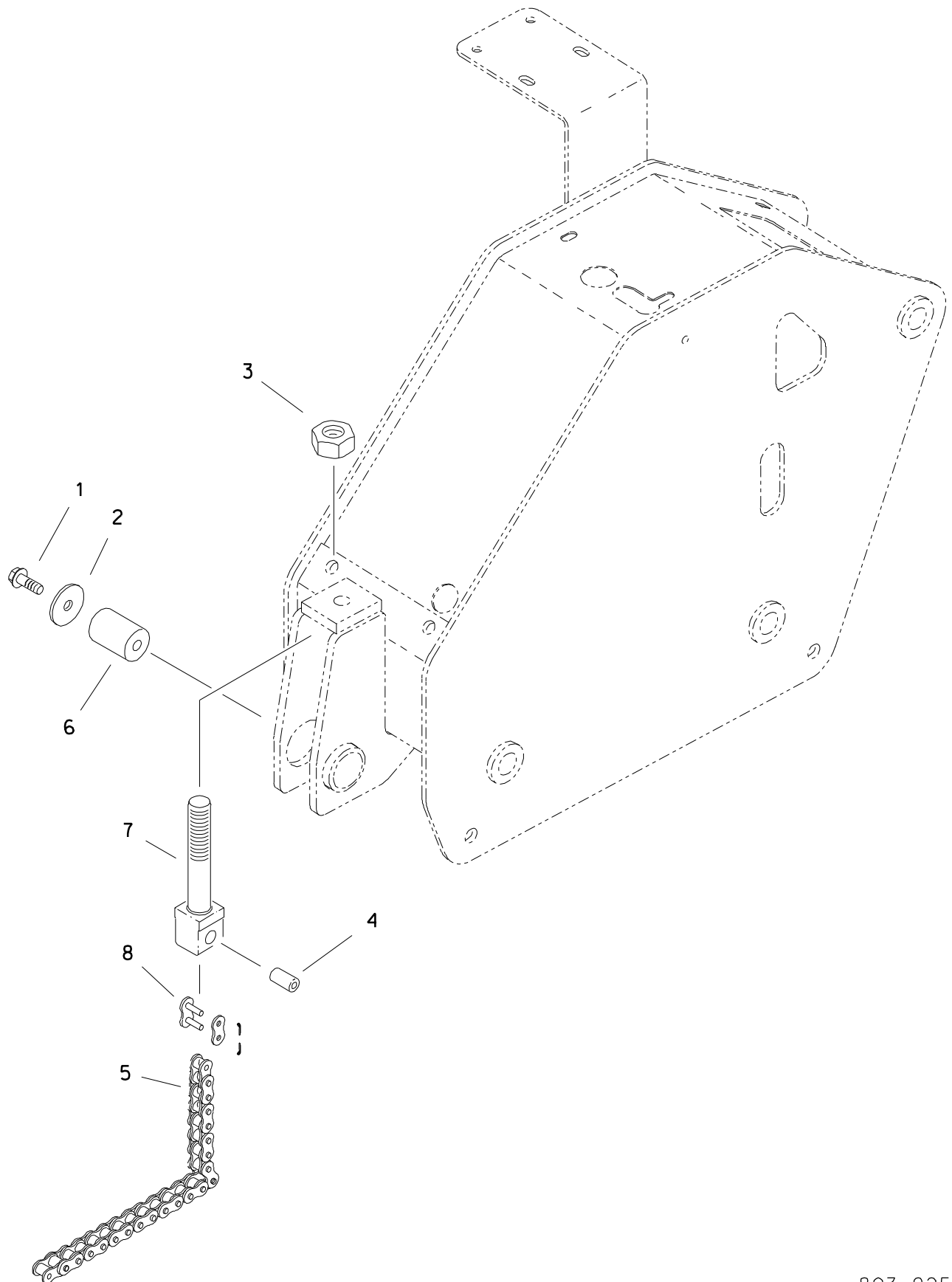

CHAIN TENSIONER

REF NO.	PART NUMBER	QTY	DESCRIPTION	REMARKS
1.	105-245	2	FLG LK SCREW (M10-1.50 X 25MM)	
2.	105-223	2	WASHER (3/8")	
3.	106-355	1	FLANGE NUT (M16 - 2.00 - 10.9)	
4.	130-323	1	ROLLER BUSHING (#100)	
5.	130-459	1	ROLLER CHAIN (#100H, 209P)	
6.	184-578	1	PIN	
7.	353-615	1	CHAIN ADJUSTER	
8.	130-401	2	CONNECTOR LINK (#100)	

FOOTNOTES

TRACK GROUP (RUBBER)

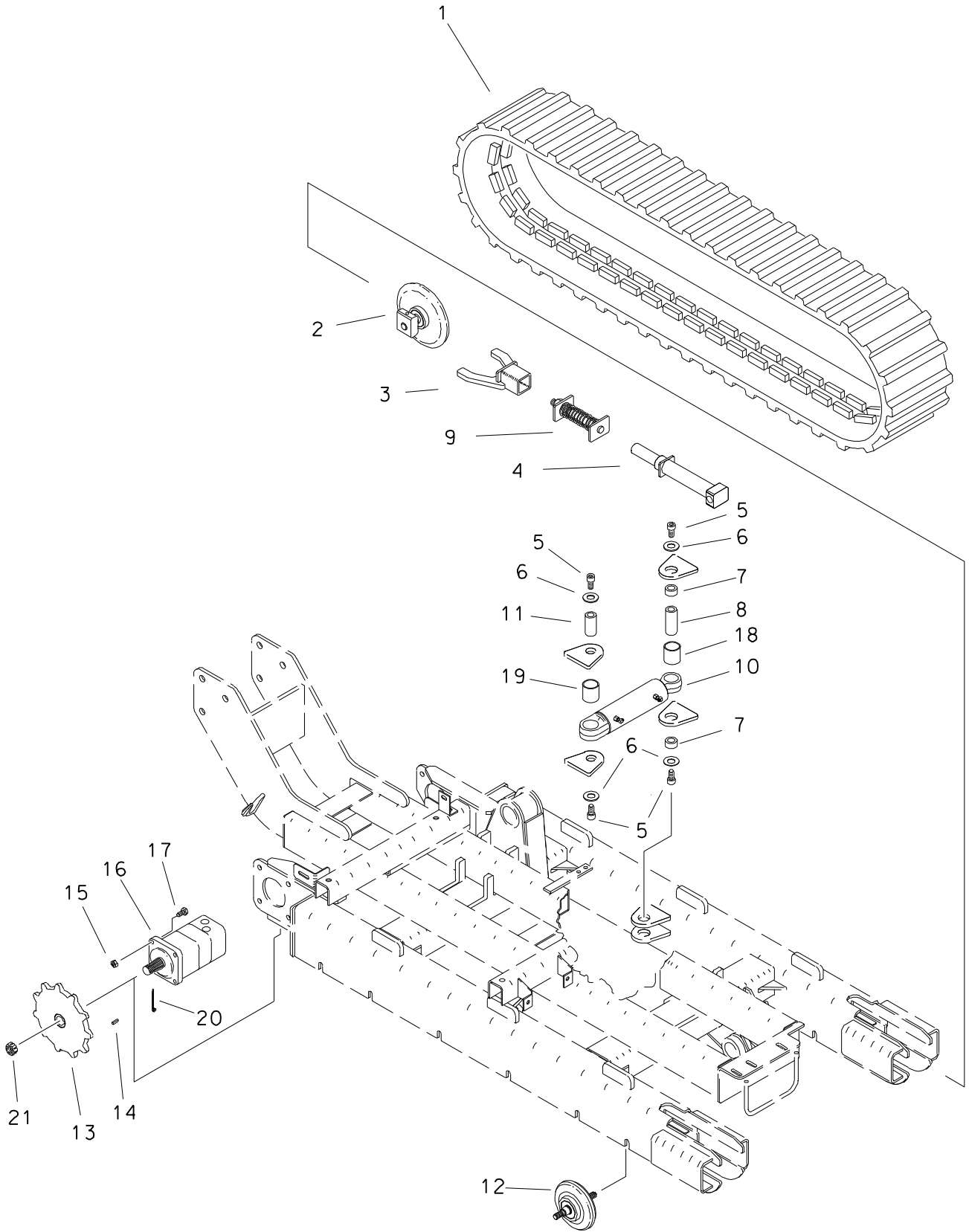

TRACK GROUP (RUBBER)

REF NO.	PART NUMBER	QTY	DESCRIPTION	REMARKS
1.	353-784	2	RUBBER TRACK	
2.	347-019	2	IDLER	
3.	356-272	2	YOKER	
4.	356-273	2	GREASE CYLINDER	
5.	105-248	4	SCREW (M12-1.75 X 25MM,ALN)	
6.	105-475	4	WASHER (1/2)	
7.	184-540	2	SPACER	
8.	183-975	1	PIN (25.4 X 68)	
9.	356-271	2	SPRING	
10.	151-076	1	CYL (2.0" X 1.000" X 10.000")	
11.	183-901	1	PIN (31.8 X 68)	
12.	355-972	12	ROLLER	
13.	356-284	2	MOTOR SPROCKET WELDMENT	
14.	166-846	2	WOODRUFF KEY (5/16" X 1")	
15.	105-065	8	LOCKNUT (1/2-NC)	
16.	158-810	2	HYDRAULIC MOTOR	
17.	106-575	8	SCREW (1/2-NC X 2-1/4")GD8	
18.	125-770	1	COMPOSITION BUSHING (1")	
19.	125-771	1	COMPOSITION BUSHING	
20.	105-518	2	COTTER PIN (1/8" X 1-1/2")	
21.	107-034	2	SLOTTED HEX NUT (1.000-NF-20)	

FOOTNOTES

TRACK GROUP (STEEL)

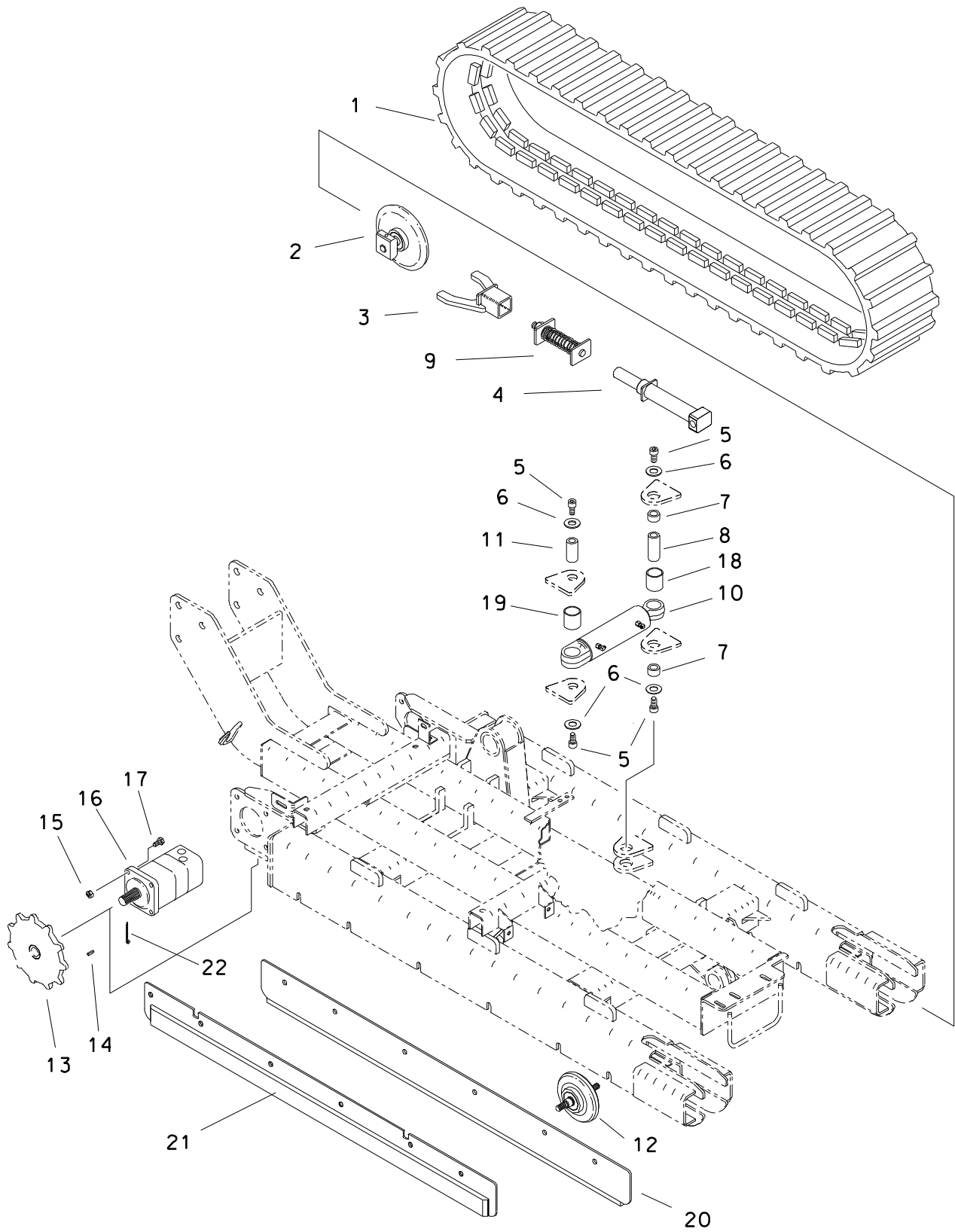

TRACK GROUP (STEEL)

REF NO.	PART NUMBER	QTY	DESCRIPTION	REMARKS
1.	353-205	2	STEEL TRACK	
2.	353-212	2	IDLER	
3.	353-208	2	YOKER	
4.	356-273	2	GREASE CYLINDER	
5.	105-248	4	SCREW (M12-1.75 X 25MM,ALN)	
6.	105-475	4	WASHER (1/2)	
7.	184-540	2	SPACER	
8.	183-975	1	PIN (25.4 X 68)	
9.	356-271	2	SPRING	
10.	151-076	1	CYL (2.0" X 1.000" X 10.000")	
11.	183-901	1	PIN (31.8 X 68)	
12.	353-213	12	ROLLER	
13.	353-191	2	SPROCKET	
14.	165-953	2	WOODRUFF KEY (5/16" X 1-3/8")	
15.	105-065	8	LOCKNUT (1/2-NC)	
16.	158-810	2	HYDRAULIC MOTOR	
17.	106-575	8	SCREW (1/2-NC X 2-1/4")GD8	
18.	125-770	1	COMPOSITION BUSHING (1")	
19.	125-771	1	COMPOSITION BUSHING	
20.	353-210	1	SIDE PLATE	
	353-218	1	SIDE PLATE	
21.	353-219	1	SIDE PLATE	
	353-220	1	SIDE PLATE	
22.	105-518	2	COTTER PIN (1/8" X 1-1/2")	

FOOTNOTES

TENSION SPRING

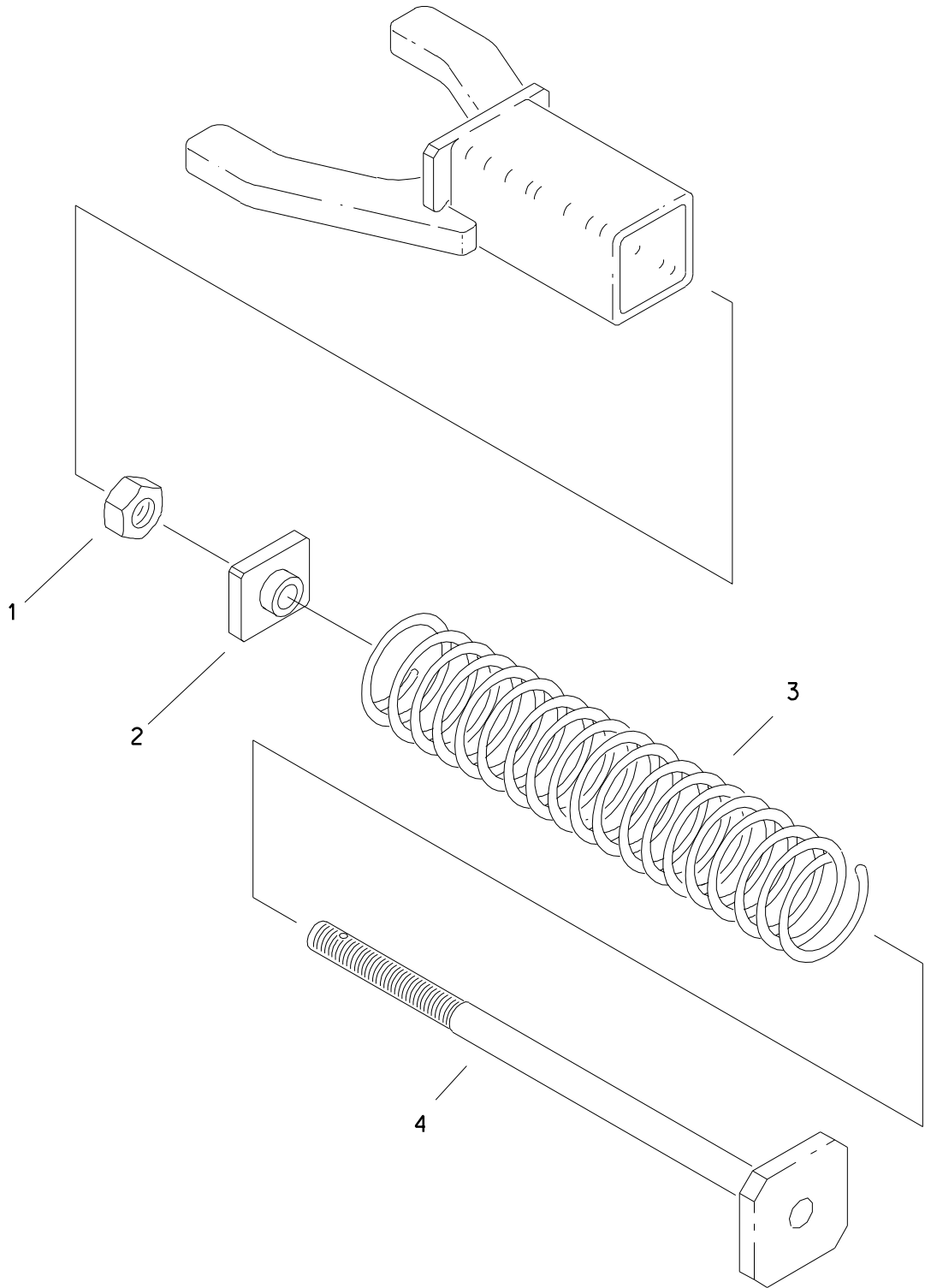

TENSION SPRING

REF NO.	PART NUMBER	QTY	DESCRIPTION	REMARKS
	356-271		SPRING	INCL REF NO.'S 1 THRU 4
1.	106-851	1	LOCKNUT (M18-2.5)	
2.	347-035	1	END PLATE	
3.	117-057	1	TRACK SPRING	
4.	347-034	1	SHAFT	

FOOTNOTES

GREASE CYLINDER

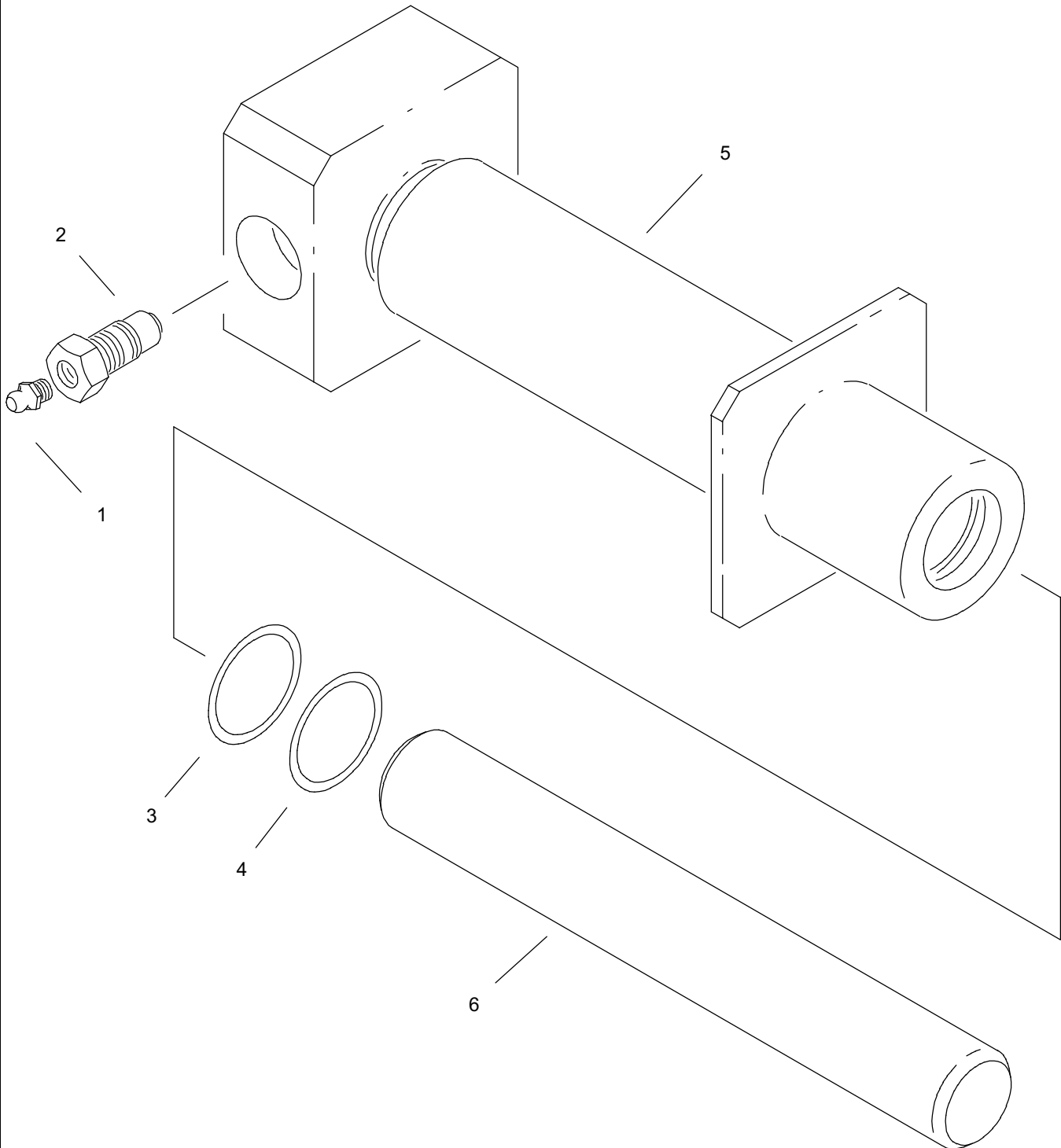

GREASE CYLINDER

REF NO.	PART NUMBER	QTY	DESCRIPTION	REMARKS
	151-177		GREASE CYLINDER	INCL REF NO'S 3 - 6; SEE FOOTNOTE 1
	356-971		GREASE CYLINDER PARTS ASS'Y	EARLY STYLE
	356-273		GREASE CYLINDER	USE ON 921 ONLY
1.	115-019	1	ZERK (02N)	
2.	159-093	1	RELIEF VALVE (5/8-NF,02N)	
3.	157-078	1	O-RING (222 D90)	
4.	155-712	1	BACKUP RING (222 D90)	
5.	356-970	1	GREASE CYLINDER BARREL	
	347-038	1	GREASE CYLINDER WELDMENT	USE ON 921 ONLY
6.	356-969	1	GREASE CYLINDER ROD	
	347-039	1	GREASE CYLINDER ROD	USE ON 921 ONLY

NOT SHOWN:

FOOTNOTES:

NOTE:

IDLER

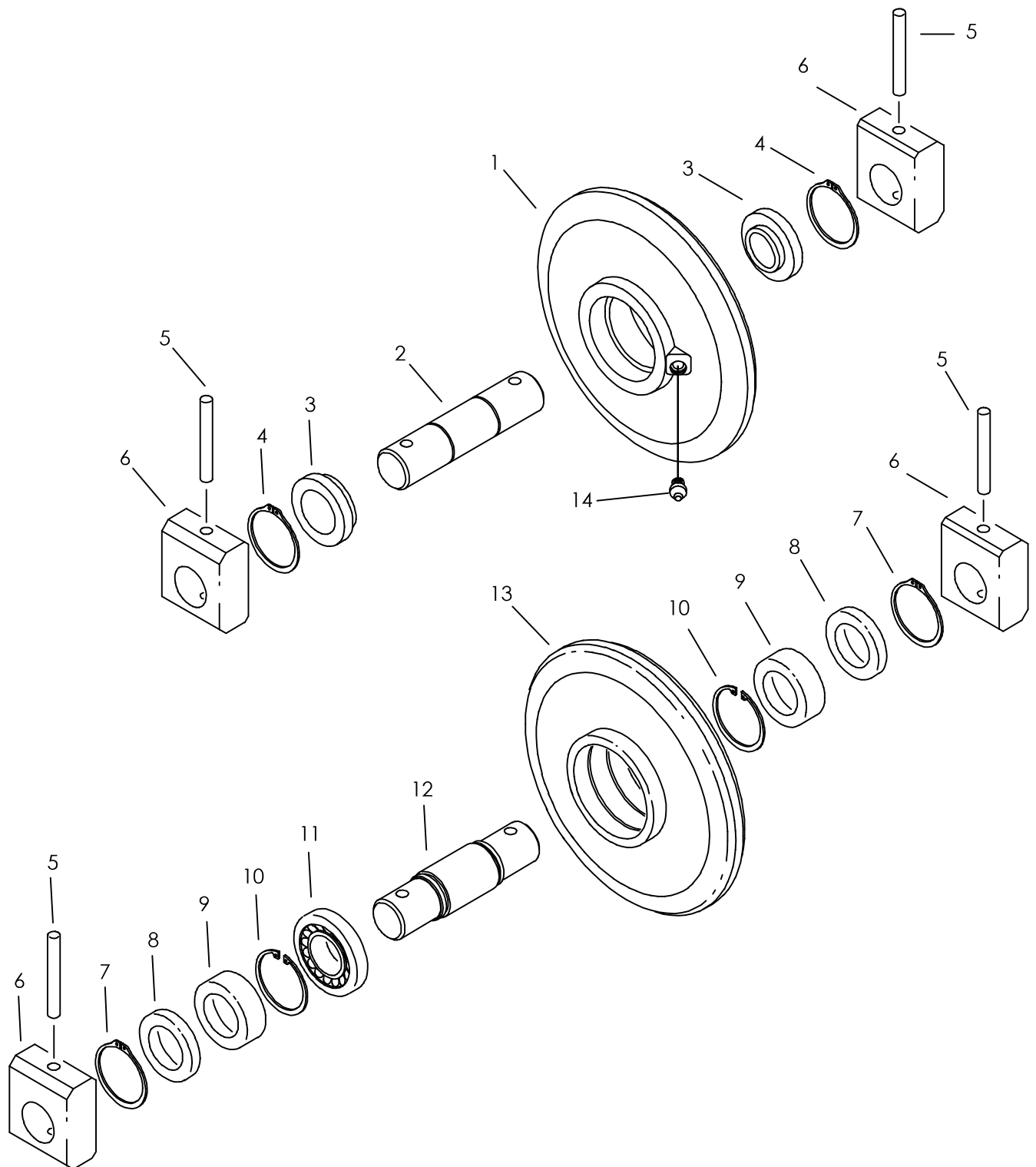

IDLER

REF NO.	PART NUMBER	QTY	DESCRIPTION	REMARKS
1.	347-019	1	IDLER	SEE FOOTNOTES 1 & 3
2.	167-340	1	IDLER SHAFT	
3.	125-550	2	BALL BEARING (1.378") GREASABLE	
4.	115-465	2	EXTERNAL SNAP RING (1.375")	
5.	105-561	2	ROLL PIN (3/8" X 2-3/4")	
6.	347-023	2	PUSH BLOCK	
7.	118-021	2	EXTERNAL SNAP RING (1.500")	
8.	110-478	2	MACHINERY BUSHING (1.585")	
9.	157-650	2	INTERNAL SEAL (1.574")	
10.	115-464	2	INT SNAP RING (3.149")	
11.	125-107	1	BALL BEARING (1.574")	
12.	347-024	1	IDLER SHAFT	
13.	375-277	1	IDLER	SEE FOOTNOTE 2
14.	115-001	1	ZERK (02N)	

NOT SHOWN:

FOOTNOTES:

NOTE:

1. REF NO'S 1 - 6 & 14, NEW STYLE (DOUBLE BEARING)
2. REF NO'S 5 - 13 OLD STYLE (SINGLE BEARING)
3. AFTER ASSEMBLY, ADD GREASE TO IDLER.

ROLLER ASSEMBLY

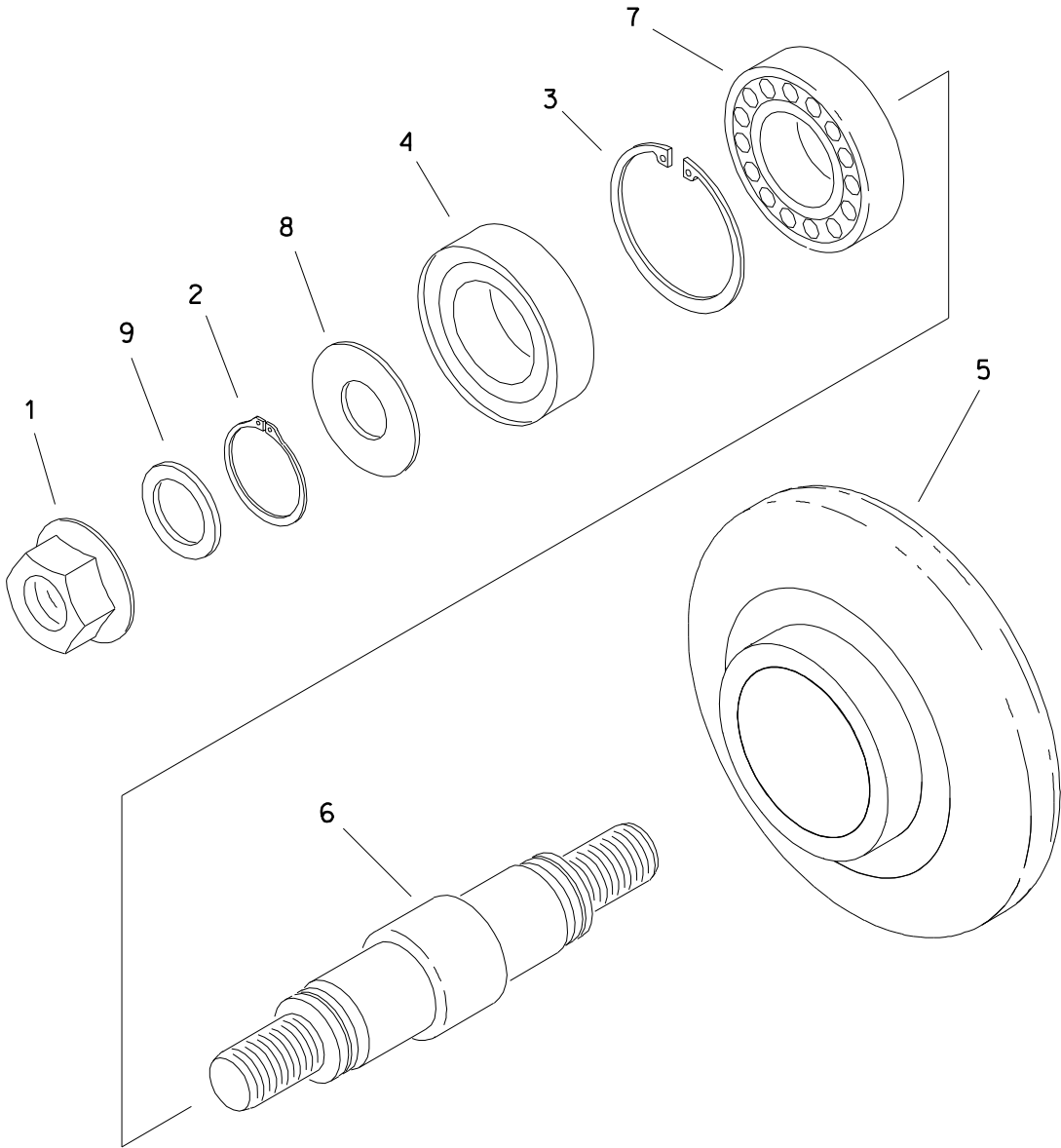

ROLLER ASSEMBLY

REF NO.	PART NUMBER	QTY	DESCRIPTION	REMARKS
	355-972		ROLLER ASSEMBLY	(RUBBER TRACK) INC REF NO.'S 1 TRHU 9
1.	106-031	2	LOCKNUT (M12-1.75)	
2.	115-545	2	EXTERNAL SNAP RING	
3.	118-018	2	INTERNAL SNAP RING	
4.	157-500	2	INTERNAL SEAL	
5.	356-265	1	ROLLER	
6.	355-942	1	ROLLER SHAFT	
7.	125-094	2	BALL BEARING (.787"IDX1.805"ID)	
8.	110-773	2	MACHINERY BUSHING (3/4" X 18 GA)	
9.	105-059	2	WASHER (7/16")	

FOOTNOTES

WATER TANK SUPPORT

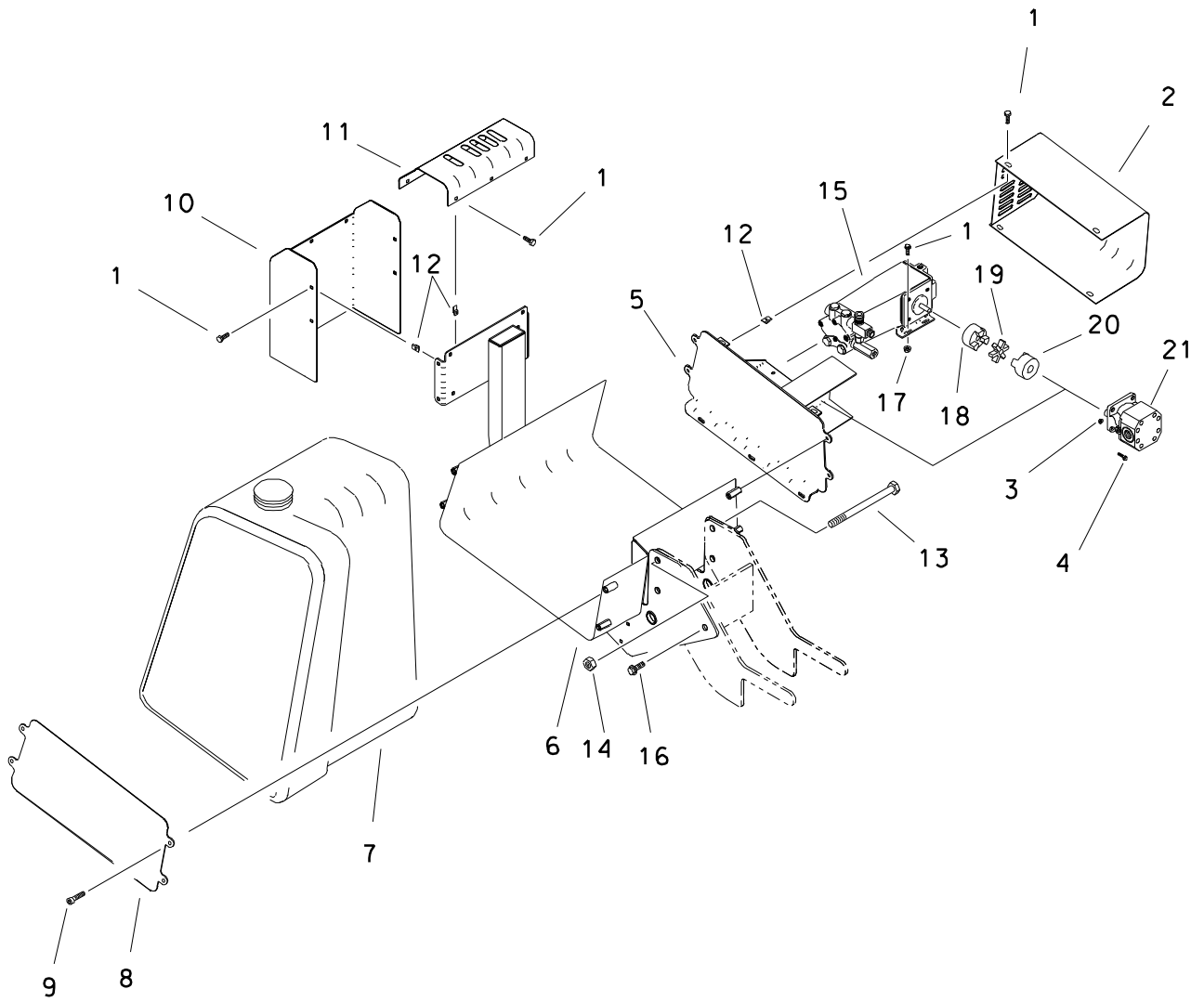

WATER TANK SUPPORT

REF NO.	PART NUMBER	QTY	DESCRIPTION	REMARKS
1.	106-381	16	FLG LOCK SCREW (M8-1.25 X 25MM)	
2.	353-823	1	PUMP COVER	
3.	105-003	4	FLG LOCKNUT (5/16-NC)	
4.	105-823	4	FLG LK BOLT (5/16-NC X 3/4")	
5.	353-180	1	SIDE PLATE	
6.	353-822	1	WATER TANK SUPPORT	SEE FOOTNOTE 3
7.	364-276	1	WATER TANK	
	364-373		CAP/LID (5")	
	514-400		BK CONNECTOR (16NF-16NFBK)	
	157-490		BK CONNECTOR (16NF, POLY)	
	157-189		O-RING (325 D70)	
	190-053		TANK REPAIR KIT	
8.	353-168	1	SIDE PLATE	
9.	105-248	8	SCREW (M12-1.75 X 25MM, ALN)	
10.	353-864	1	VALVE COVER	
11.	353-597	1	VALVE COVER	
12.	106-551	12	CLIP NUT (M8-1.25)	
13.	106-188	2	BOLT (3/4-NC X 9-1/2")	SEE FOOTNOTE 1
14.	105-340	4	FLG LOCKNUT (3/4-NC)	
15.	158-386	1	WATER PUMP	
	157-610		OIL SEAL	
	500-768		PLUNGER SEAL KIT	
	500-767		VALVE REPAIR KIT	
	500-843		PLUNGER KIT	
16.	106-098	2	FLG BOLT (3/4-NC X 2")	
17.	106-386	4	FLG LOCKNUT (M8-1.25)	
18.	357-909	1	FLANGED COUPLER (3/4" ID)	SEE FOOTNOTE 2
19.	357-908	1	INSERT CENTER (1.070")	
20.	353-200	1	FLANGED COUPLER (1/2" ID)	
21.	158-405	1	HYDRAULIC MOTOR	
	190-820	1	SEAL REPAIR KIT	

FOOTNOTES

- 1. TORQUE BOLT TO 271 N-M (200 FT-LBS)
- 2. TORQUE BOLT TO 534 N-M (400 FT-LBS)
- 3. HOLES MAY REQUIRE MODIFICATION FOR NEW FITTINGS.

REFER TO O-RING CHART (800-301) IN BACK OF THE BOOK FOR REPLACEMENT OF O-RINGS.

MUD MIXING SYSTEM

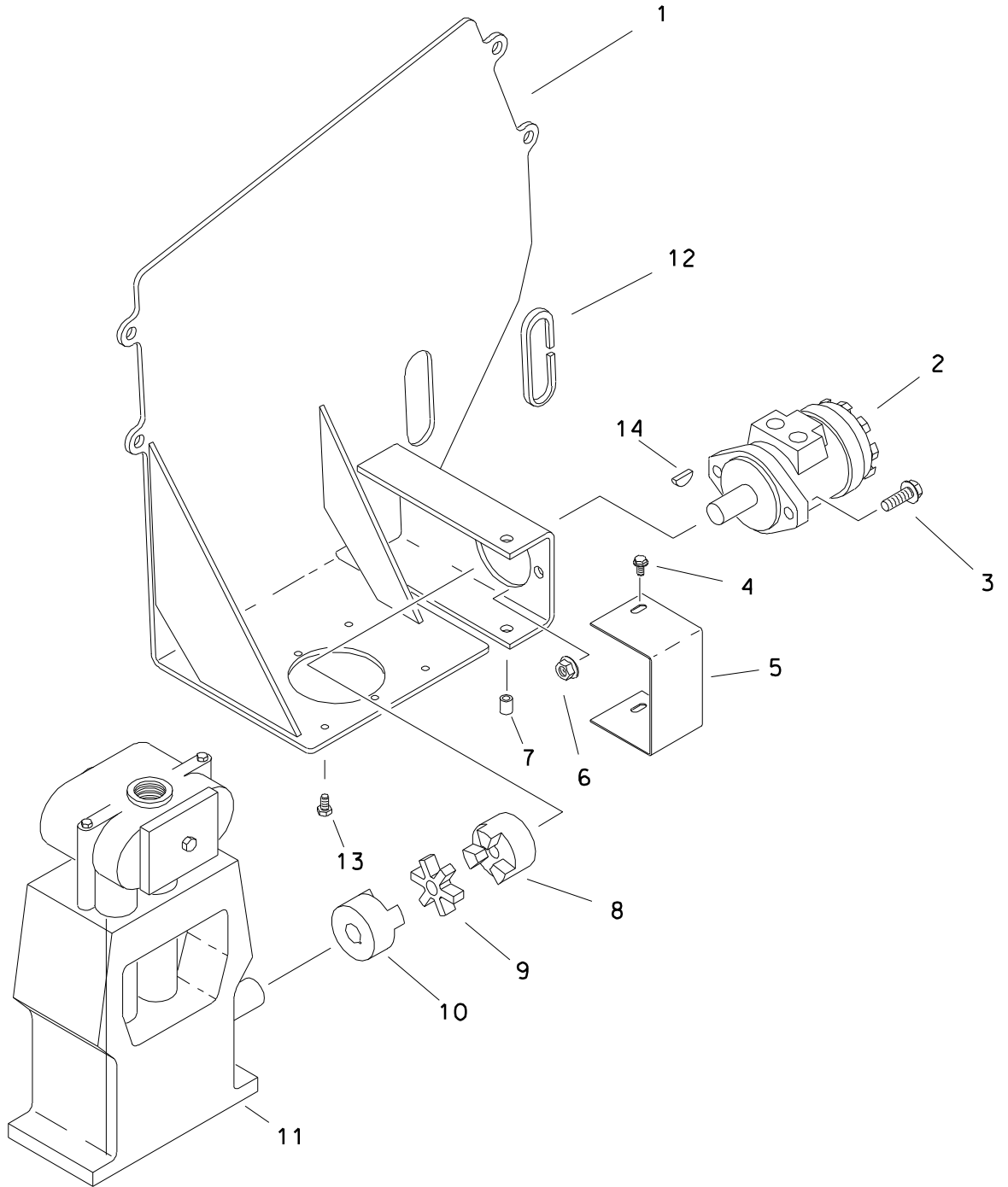

MUD MIXING SYSTEM

REF NO.	PART NUMBER	QTY	DESCRIPTION	REMARKS
1.	353-251	1	SIDE PLATE	
2.	158-403	1	GEAR MOTOR (3.0 CUI/REV)	
	190-725	1	SEAL KIT	
3.	106-632	2	FLG LK SCREW (M12-1.75 X 35MM)	
4.	106-380	3	FLG LK SCREW (M8-1.25 X 16MM)	
5.	353-253	1	COVER	
6.	106-709	2	FLG LK NUT (M12-1.75)	
7.	106-565	3	NUTSERT (M8-1.25)	
8.	355-971	1	COUPLING HALF (1" SHAFT)	
9.	353-245	1	HYTREL SPIDER (LOVEJOY LO-95)	
10.	353-246	1	COUPLING HALF (7/8" SHAFT)	
11.	158-411	1	MUD PUMP	
	197-171		REBUILT 158-411 MUD PUMP	
	157-157	6	O-RING (213 D90)	
	157-158	2	O-RING (015 D90)	
	157-159	2	O-RING (033 D90)	
	165-845	2	CYNLINDER GASKET	
	499-014	1	PUMP CASE	
	499-015	2	VALVE CHAMBER / FLUID CYLINDER	
	500-900	2	CUP, 1 5/8"	
	500-901	4	VALVE SEAT	
	500-902	4	DISC & SPRING ASS'Y	
	500-903	2	CERAMIC CYLINDER	
	499-044	4	VALVE CAGE	
	499-086	2	VALVE COVER	
	499-087	2	UMBRELLA WASHER	
12.	115-663	1	GROMMET EDGING (6.35MM) GROMMET EDGING (1/4")	
13.	105-827	4	FLG LK BOLT (3/8"NC X 1-1/4")	
14.	165-931	1	WODDRUFF KEY	

FOOTNOTES

REAR STABILIZER

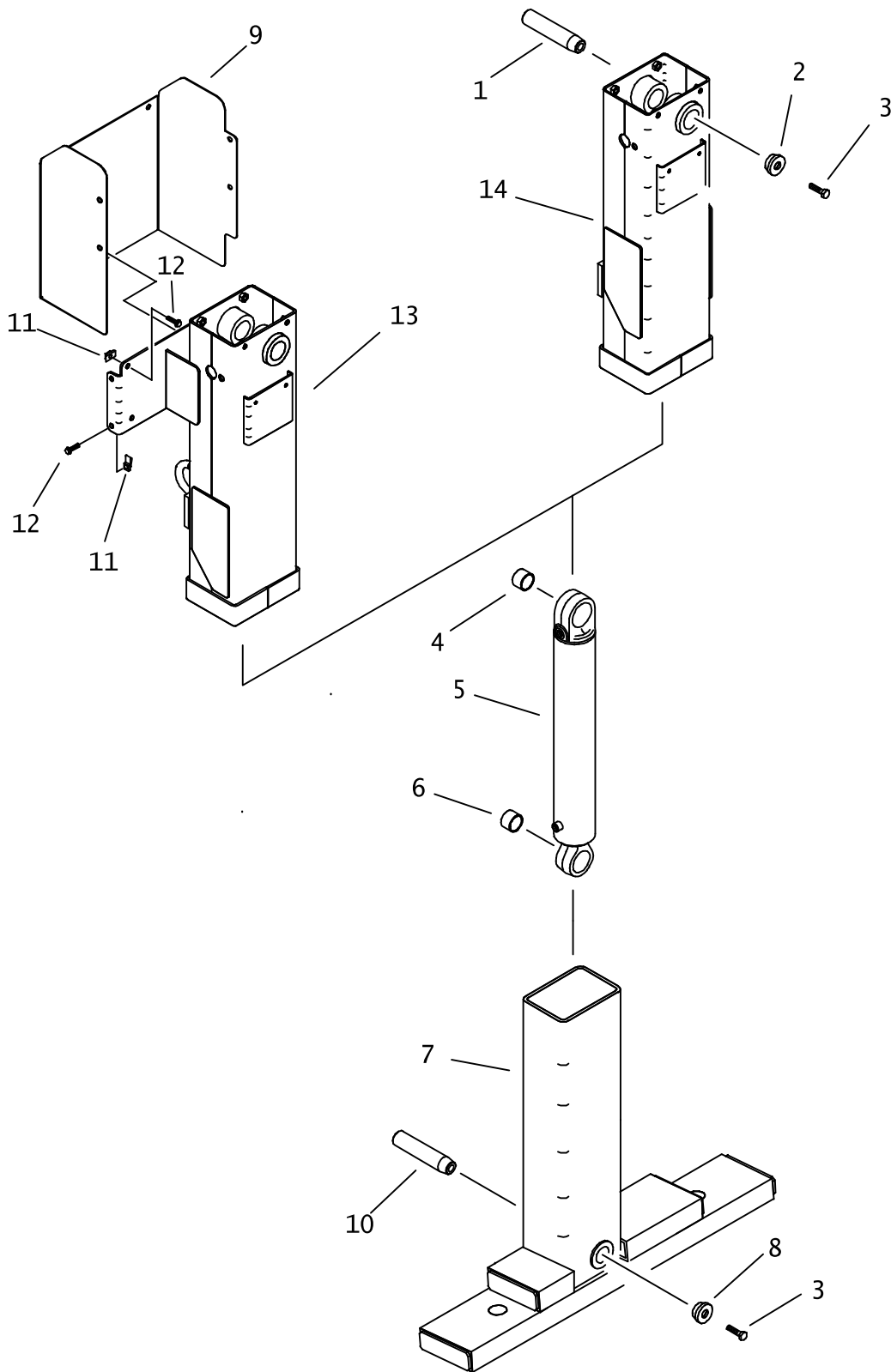

REAR STABILIZER

REF NO.	PART NUMBER	QTY	DESCRIPTION	REMARKS
1.	179-052	1	TAPERED PIN (1.75" X 6.6")	
2.	181-975	1	TAPERED INSERT (1.75")	W/O WATER TANK
3.	105-969	2	FLG BOLT (5/8-NC X 1-1/2", GD8)	
4.	125-773	1	COMPOSITION BUSHING (1.75")	
5.	151-147	1	CYL (3" X 1.5" X 20") 32"	BEGINS WITH S/N 2M2288
6.	125-772	1	COMPOSITION BUSHING (1.5")	
7.	353-291	1	STABILIZER BASE	BEGINS WITH 2M2288
8.	181-974	1	TAPERED INSERT (1.5")	
9.	353-598	1	VALVE ENCLOSURE	W/O WATER TANK
10.	179-033	1	TAPERED PIN (1.5" X 5.4")	WITH WATER TANK
11.	106-551	8	CLIP NUT (M8-1.25)	
12.	106-381	8	FLG LK SCREW (M8-1.25 X 25MM)	
13.	353-289	1	UPPER STABILIZER TUBE	W/O WATER TANK
14.	353-290	1	UPPER STABILIZER TUBE (WET)	WITH WATER TANK - ENDS W/ SN 2M2287

FOOTNOTES

NOTE:

F

803-579

FUEL RESERVOIR

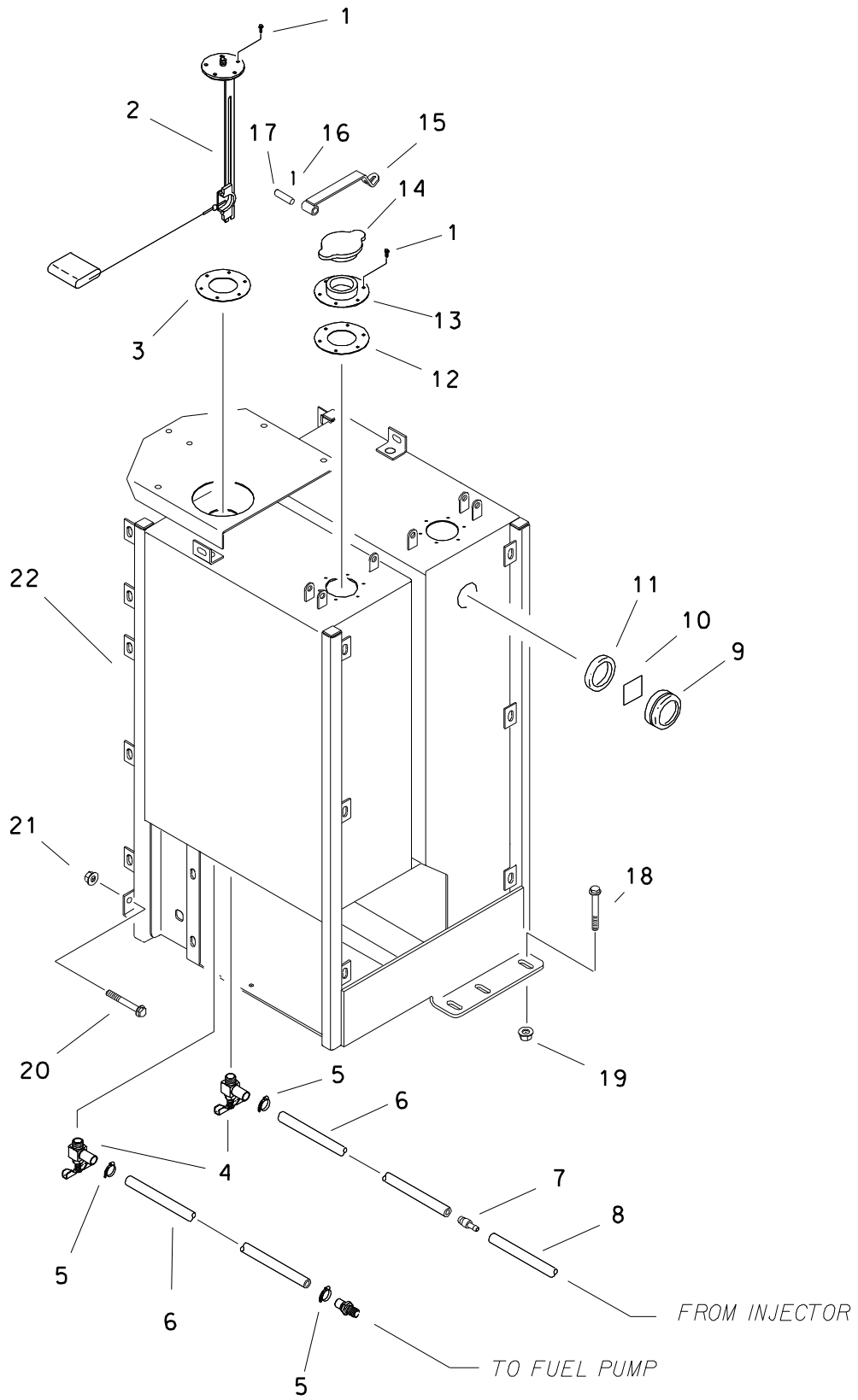

FUEL RESERVOIR

REF NO.	PART NUMBER	QTY	DESCRIPTION	REMARKS
1.	105-214	11	SCREW (#10-24 X 1/2", FLG HEX)	
2.	217-549	1	FUEL SENDER	
3.	165-704	1	GASKET	
4.	156-239	2	SLIP-ON SHUT-OFF (O2N-05H90)	
5.	110-249	4	WORM CLAMP (7MM TO 16MM) WDRM CLAMP (1/4" TO 5/8")	
6.	116-108	AR	BULK HOSE (8MM ID-4BAR) BULK HOSE (5/16" ID-50PSI)	SOLD PER 25MM-USE 407MM SOLD PER 1"-USE 16"
7.	156-253	1	SLIP-DN COUPLER (O3H-05H)	
8.	116-624	AR	BULK HOSE (4MM ID-4BAR) BULK HOSE (5/32" ID-50PSI)	SOLD PER 25MM-USE 76MM SOLD PER 1"-USE 30"
9.	116-218	1	SIGHT GLASS	
10.	360-849	1	REFLECTOR	
11.	115-320	1	GROMMET (1-1/2")	
12.	165-626	1	FILLER NECK GASKET	
13.	110-132	1	FILLER NECK	
14.	110-010	1	FILLER CAP (1-1/2")	
15.	364-332	1	FUEL CAP LOCK STRAP	
16.	105-535	1	ROLL PIN (1/8" X 5/8")	
17.	183-978	1	PIN	
18.	105-827	3	FLG LK BOLT (3/8-NC X 1-1/4")	
19.	105-834	3	FLG LOCKNUT (3/8-NC)	
20.	106-381	3	FLG LK SCREW (M8-1.25 X 25MM)	
21.	106-386	3	FLG LOCKNUT (M8-1.25)	
22.	353-700	1	MOBILING STATION	

FOOTNOTES

COVERS AND GUARDS

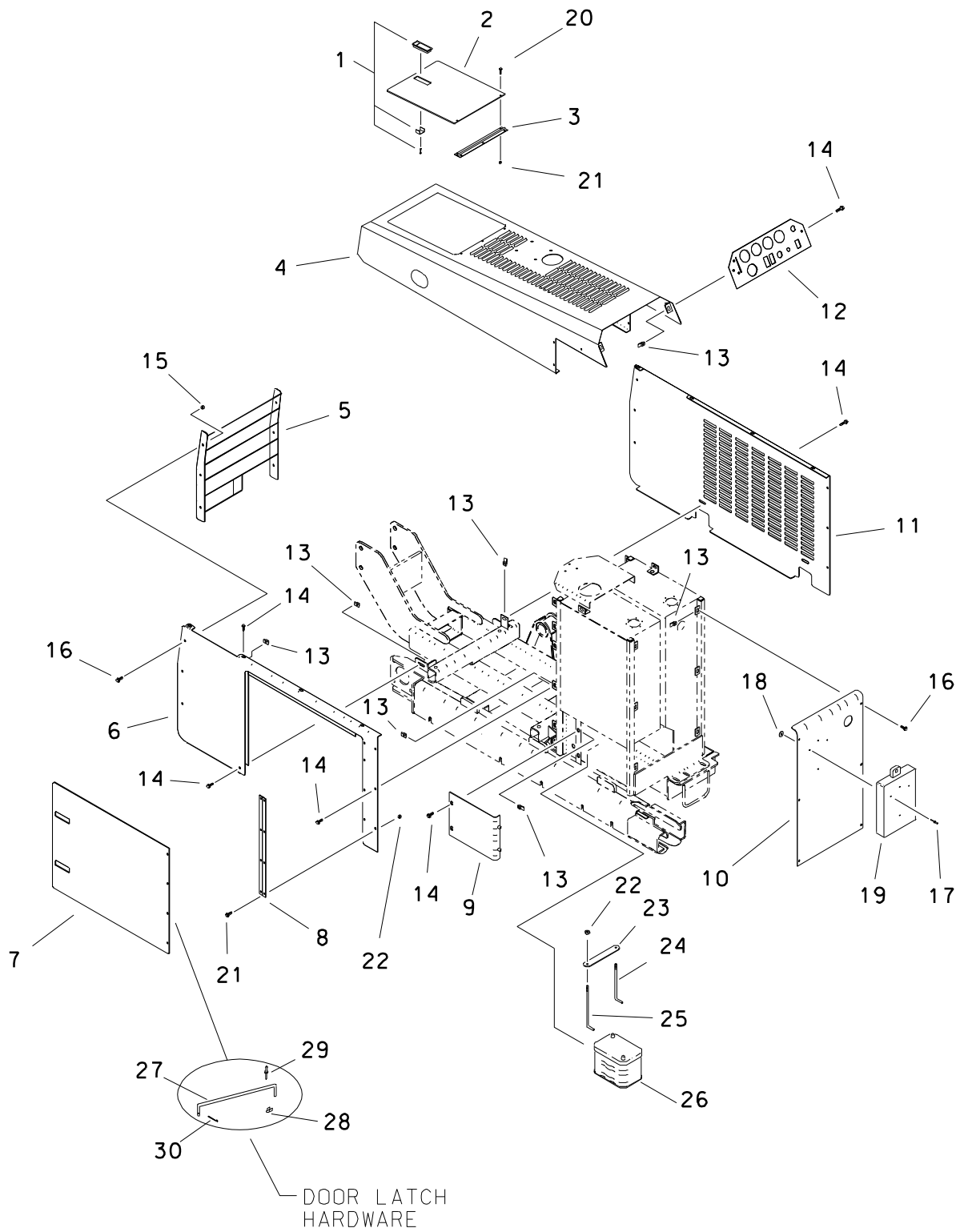

COVERS AND GUARDS

REF NO.	PART NUMBER	QTY	DESCRIPTION	REMARKS
1.	117-558	3	ADJUST LEVER LATCH (LOCKING)	
	214-961		KEY, PAIR (BASE CODE)	
	217-309		LOCK PLUG 4/LATCH (BASE CODE)	
	110-757	3	LEVER LATCH-LOCKING	
2.	344-515	1	RADIATOR DOOR	
3.	110-794	1	HINGE	
4.	353-611	1	HOOD	
5.	353-613	1	LOUVER	
6.	353-730	1	COVER PANEL	
7.	353-612	1	ACCESS DOOR	
8.	110-582	1	HINGE	
9.	353-154	1	BATTERY COVER	
10.	353-724	1	TANK COVER	
11.	353-614	1	COVER PANEL	
12.	353-723	1	INSTRUMENT PANEL	
13.	106-551	30	CLIP NUT (M8-1.25)	
14.	106-381	24	FLG LK SCREW (M8-1.25 X 25MM)	
15.	106-386	6	FLG LK NUT (M8-1.25)	
16.	106-380	12	FLG LK SCREW (M8-1.25 X 16MM)	
17.	110-560	4	POP RIVET (3/16" X 1/2")	
18.	106-205	4	WASHER (3/16")	
19.	250-622	1	MANUAL COMPARTMENT	
20.	105-836	14	FLG LK BOLT (1/4-NC X 1/2")	
21.	105-832	14	FLG LOCKNUT (1/4-NC)	
22.	105-832	2	FLG LOCKNUT (1/4-NC)	
23.	353-709	1	BATTERY HOLDER	
24.	184-723	1	BATTERY BOLT	
25.	183-934	1	BATTERY BOLT	
26.	215-275	1	BATTERY	
27.	353-172	1	BAR	
28.	353-173	1	CLIP	
29.	106-862	1	POP RIVET	
30.	105-501	1	COTTER PIN	

FOOTNOTES

SEAT MOUNT

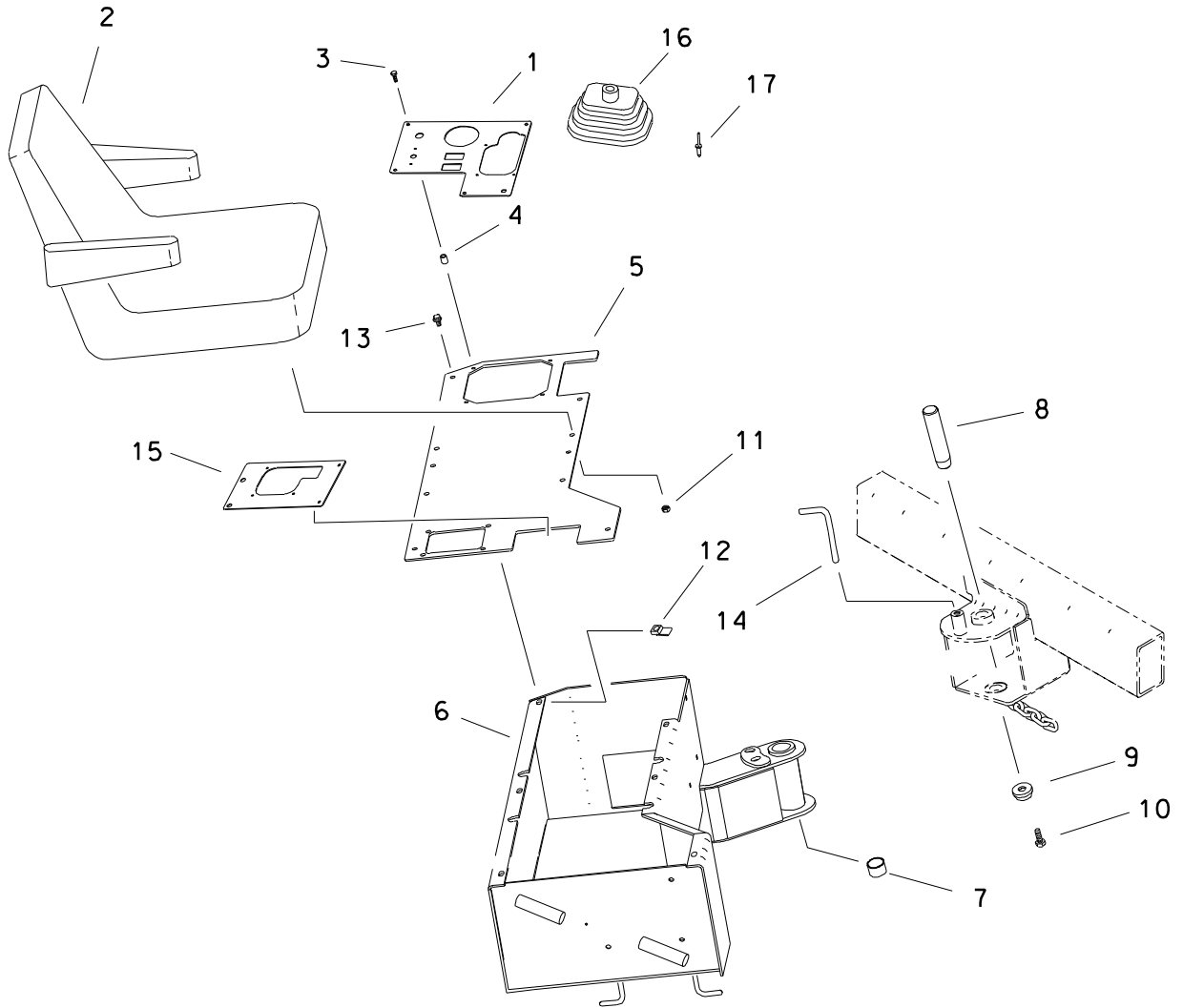

SEAT MOUNT

REF NO.	PART NUMBER	QTY	DESCRIPTION	REMARKS
1.	353-789	1	TOP PLATE	
2.	115-969	1	SEAT W/ ARM REST	
3.	106-640	8	SCREW (M6-1 X 20mm) SOC BTN HD	
4.	106-670	8	NUTSERT (M6-1.00)	
5.	353-626	1	TOP PLATE	
6.	353-617	1	SEAT PIVOT WELDMENT	
7.	125-800	2	COMPOSITION BUSHING	
8.	184-609	1	PIN	
9.	181-981	1	TAPERED INSERT (1.000")	
10.	105-245	1	SCREW (M10-1.50 X 25mm)	
11.	105-003	4	FLG LOCKNUT (5/16-NC)	
12.	106-551	6	CLIP NUT (M8-1.25)	
13.	106-381	6	FLG LK SCREW (M8-1.25 X 25mm)	
14.	184-806	1	PIN	
15.	353-242	1	TOP PLATE	
16.	353-243	2	RUBBER BOOT	
17.	110-348	8	POP RIVET (3/16" X .664")	

FOOTNOTES

ENGINE COMPONENTS

ENGINE

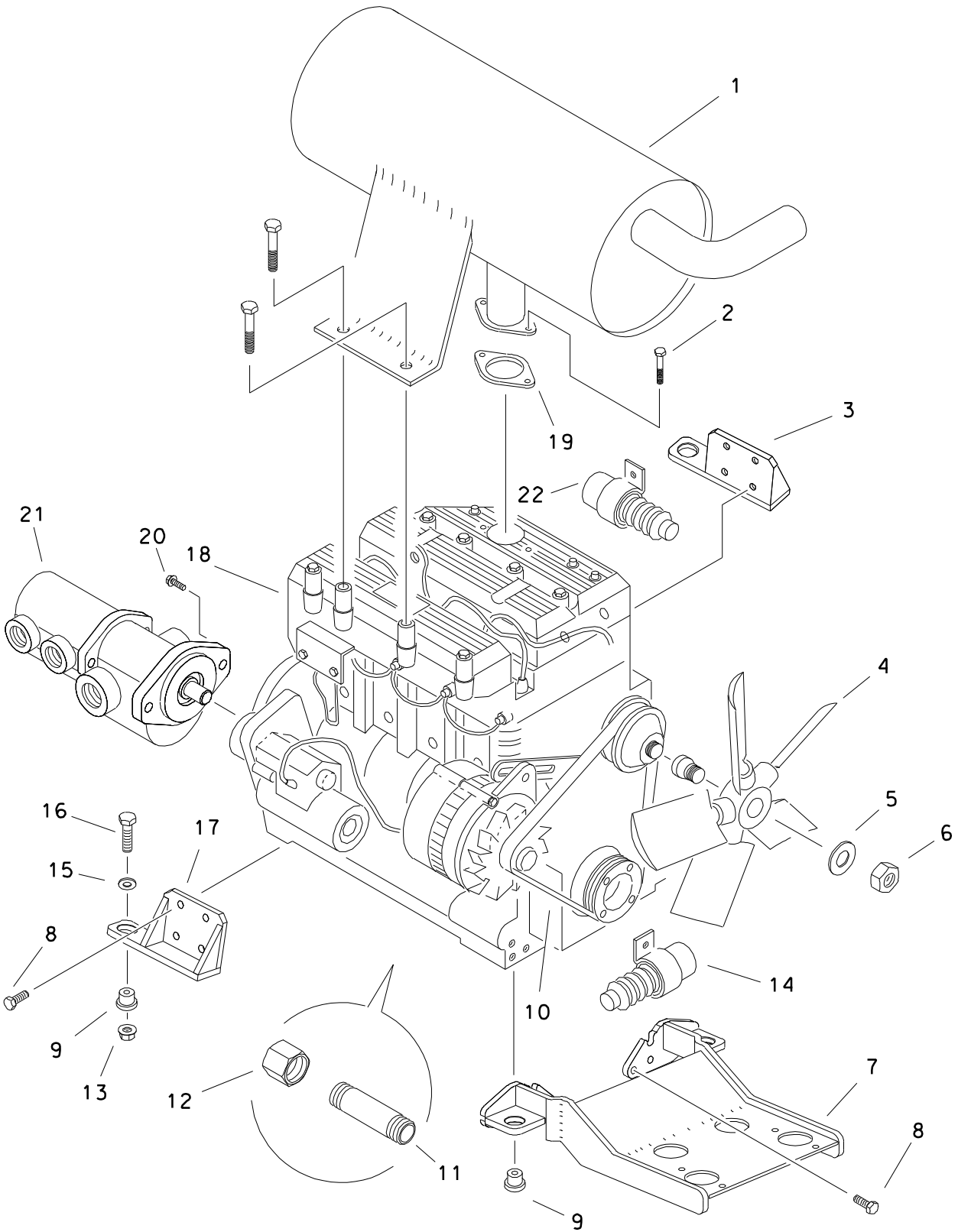

ENGINE

REF NO.	PART NUMBER	QTY	DESCRIPTION	REMARKS
1.	196-247	1	MUFFLER	
2.	105-274	2	SCREW (M10-1.5 X 20MM)	
3.	353-684	1	LEFT REAR ENGINE MOUNT	
4.	196-252	1	COOLING FAN	
5.	105-444	1	WASHER (1-1/4")	
6.	194-408	1	FAN NUT	
7.	353-745	1	FRONT ENGINE MOUNT	
8.	105-245	14	BOLT (M10-1.50 X 25MM)	
9.	317-032	4	T-MOUNT GROMMET (1-1/8")	
10.	170-097	1	ALT/FAN BELT	
11.	115-161	1	NIPPLE (08N X 3-1/2")	
12.	514-106	1	CAP (08NF)	
13.	105-833	4	FLG LOCKNUT (1/2-NC)	
14.	217-857	1	THROTTLE SOLENOID	
15.	105-088	4	WASHER (9/16")	
16.	105-002	4	SCREW (1/2-NC X 2-1/4")	
17.	353-670	1	RIGHT REAR ENGINE MOUNT	
18.	194-412	1	ENGINE (LISTER-PETTER, LPSW4)	
19.	165-771	1	EXHAUST FLANGE GASKET	
20.	105-826	2	FLG LK BOLT (3/8-NC X 1")	
21.	158-787	1	TANDEM HYDRAULIC PUMP	
	500-461	-	SEAL REPAIR KIT	
22.	217-862	1	FUEL SOLENOID	

NOT SHOWN

194-401	DIPSTICK
217-736	OIL PRESSURE SWITCH
194-405	WATER PUMP
194-406	FUEL LIFT PUMP
165-772	THERMOSTAT HOUSING GASKET
194-404	THERMOSTAT
194-407	STARTER
159-141	(ENGINE) OIL FILTER ELEMENT
194-421	FLYWHEEL END SAE A ADAPTER PLATE
194-422	SPLINE HUB (11 TOOTH)
194-423	FLYWHEEL END DRIVE MEMBER
194-426	JT820 FLYWHEEL PUMP ADAPTER KIT (INCLUDES 194-421, 194-422, 194-423 W/ MOUNTING HARDWARE)

THROTTLE

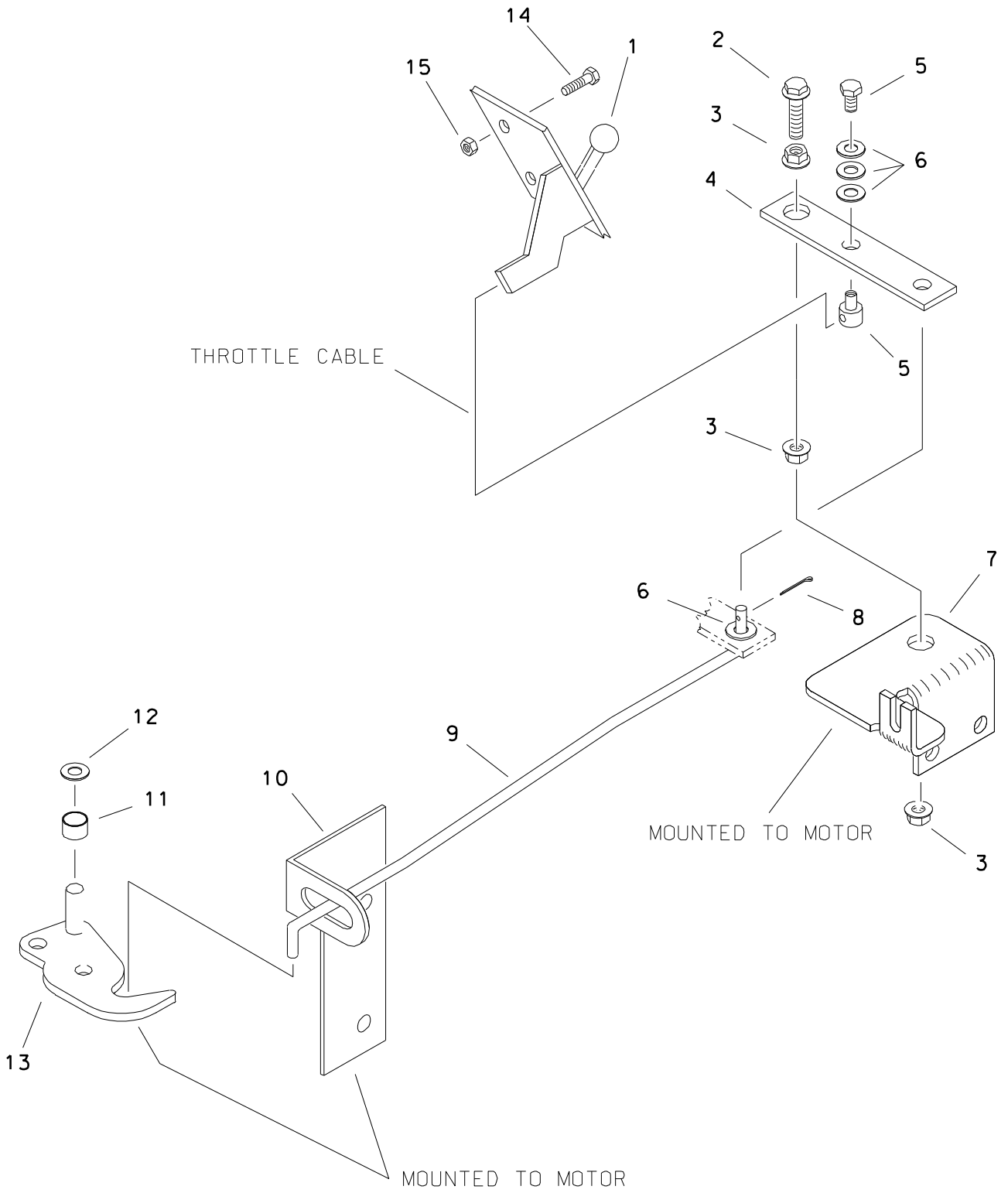

THROTTLE

REF NO.	PART NUMBER	QTY	DESCRIPTION	REMARKS
1.	196-080	1	THROTTLE CABLE	
2.	106-381	1	FLG LK SCREW (M8-1.25 X 25MM)	
3.	106-380	3	FLG LK NUT (M8-1.25)	
4.	353-792	1	THROTTLE LINK	
5.	195-953	1	CABLE SWIVEL (.031")	
6.	106-076	4	WASHER (1/4")	
7.	357-784	1	LINKAGE PLATE	
8.	105-512	1	COTTER PIN (3/32" X 3/4 ")	
9.	357-783	1	THROTTLE ROD	
10.	344-757	1	GUIDE PLATE	
11.	125-828	1	BEARING	
12.	105-573	1	CHECK NUT	
13.	353-134	1	THROTTLE LINK WELDMENT	
14.	105-836	2	FLG LK BOLT (1/4-NC X 1/2")	
15.	105-832	2	FLG LOCKNUT (1/4-NC)	

FOOTNOTES

ALTERNATOR

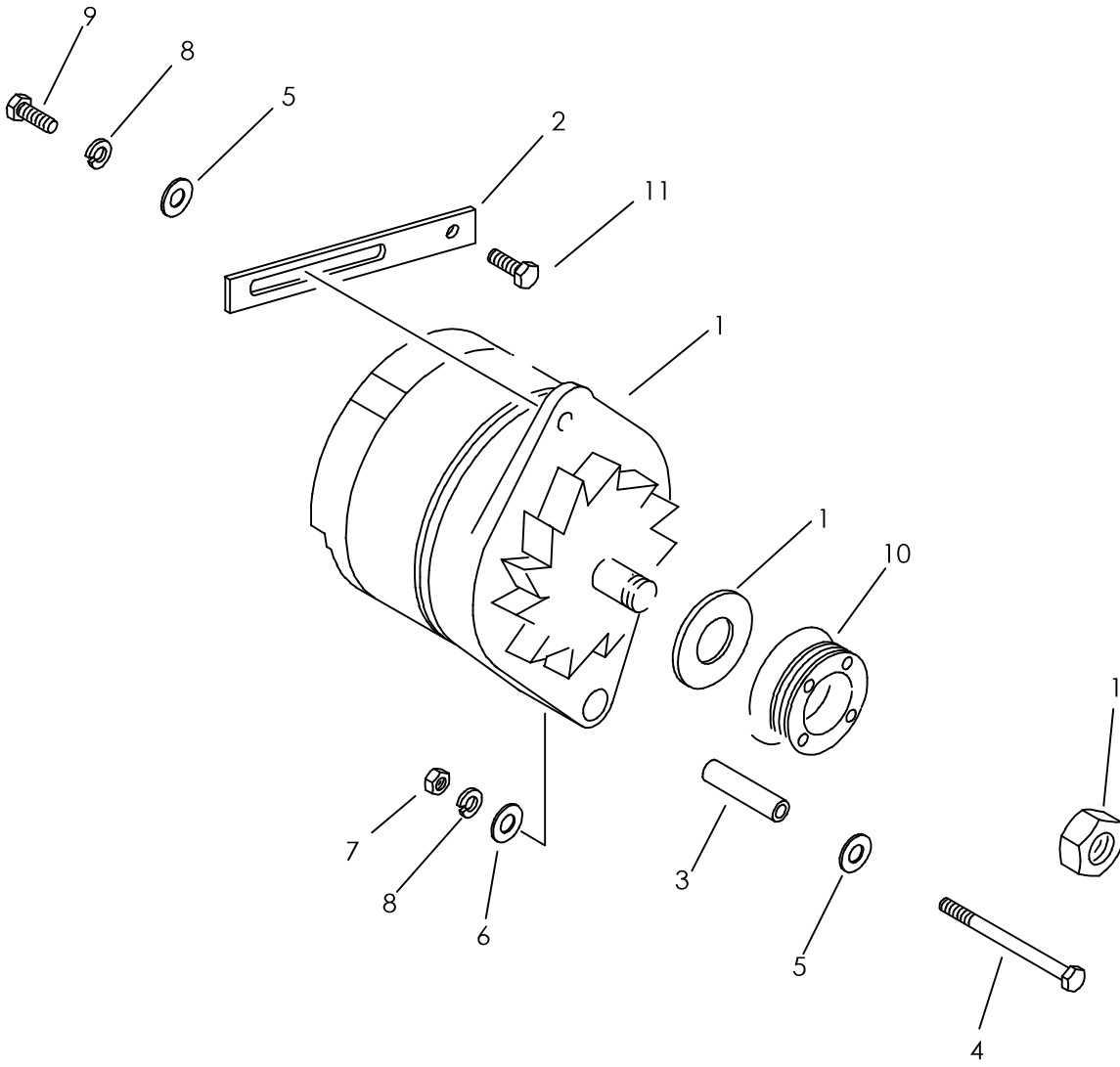

ALTERNATOR

REF NO.	PART NUMBER	QTY	DESCRIPTION	REMARKS
1.	215-159	1	ALTERNATOR (12V, 61 AMP)	TORQUE NUT TO 50 FT-LBS. OBSOLETE
	190-1244	1	ALTERNATOR KIT	INCLUDES WIRING UPGRADE
2.	363-359	1	ADJUSTING STRAP	
3.	184-334	1	SPACER (2")	
4.	106-588	1	BOLT (5/16-NC X 4", GD8)	
5.	105-117	2	WASHER (5/16")	
6.	105-095	1	WASHER (1/4")	
7.	105-089	1	LOCKNUT (5/16-NC)	
8.	105-091	2	LOCK WASHER (5/16")	
9.	106-083	1	SCREW (M8-1.25 X 20MM)	
10.	194-419	1	ALTERNATOR SHEAVE (4-GROOVE)	
11.	107-194	1	FLG SCREW (M8-1.25 X 50MM)	

NOT SHOWN:

FOOTNOTES:

NOTE:

FUEL FILTER
410SX
LISTER-PETTER DIESEL

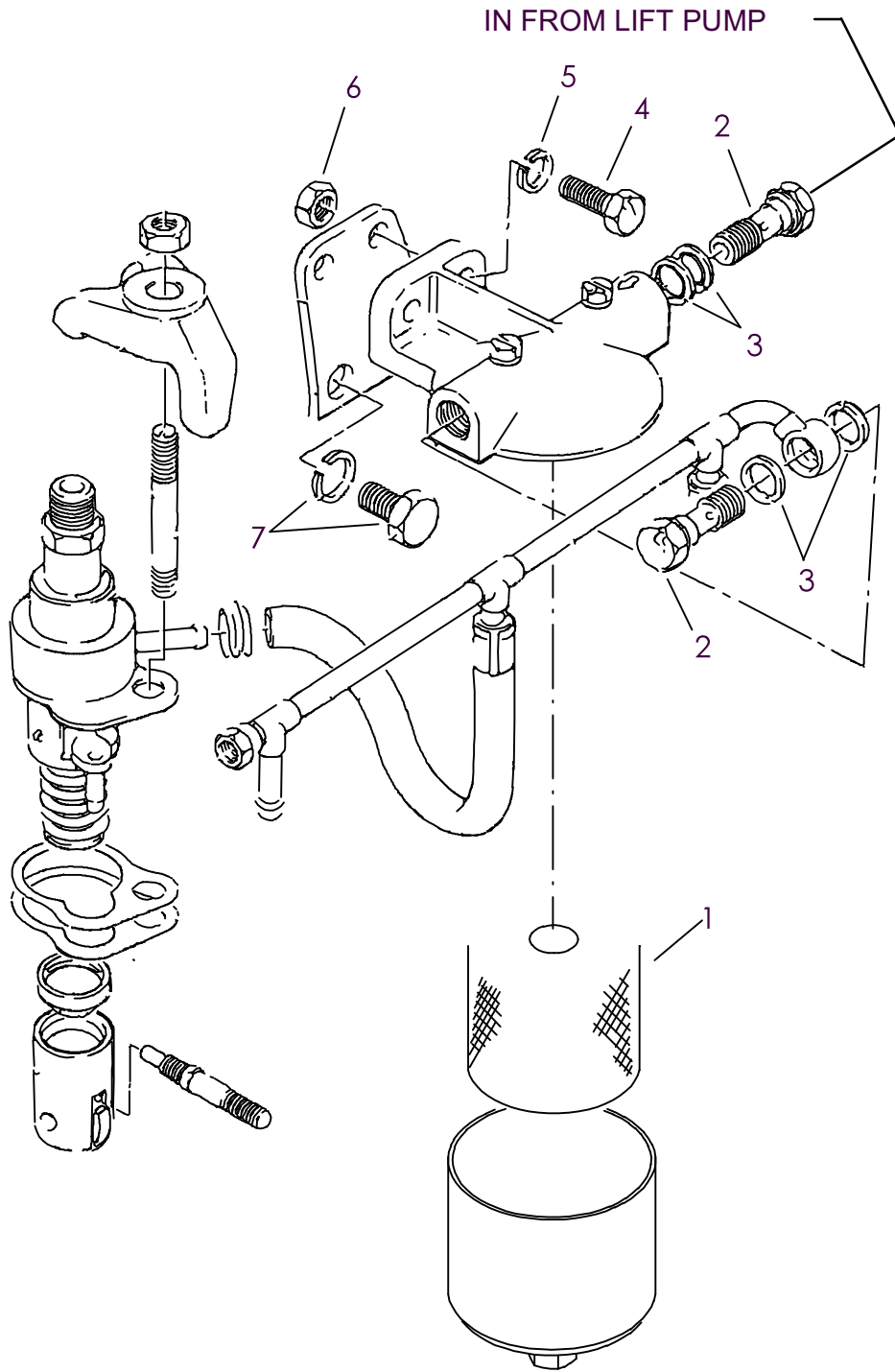

FUEL FILTER 410SX LISTER-PETTER DIESEL

REF NO.	PART NUMBER	QTY	DESCRIPTION	REMARKS
1.	159-142	1	FUEL FILTER ELEMENT (CARTRIDGE)	ENDS WITH ENGINE S/N 4600914
	194-420	1	FUEL FILTER ELEMENT (SPIN-ON)	BEGINS WITH ENGINE S/N 4600915
2.	156-279	2	BANJO BOLT (M14-1.50 X 25MM)	
3.	156-280	4	SEAL WASHER (.531", COPPER)	
4.	106-270	2	SCREW (M6-1.00 X 20MM)	
5.	106-227	2	LOCK WASHER (M6)	
6.	106-106	2	NUT (M6-1.00)	
7.	106-232	2	SCREW (M8-1.25 X 16MM)	

NOT SHOWN:

FOOTNOTES:

NOTE:

AIR FILTER SYSTEM

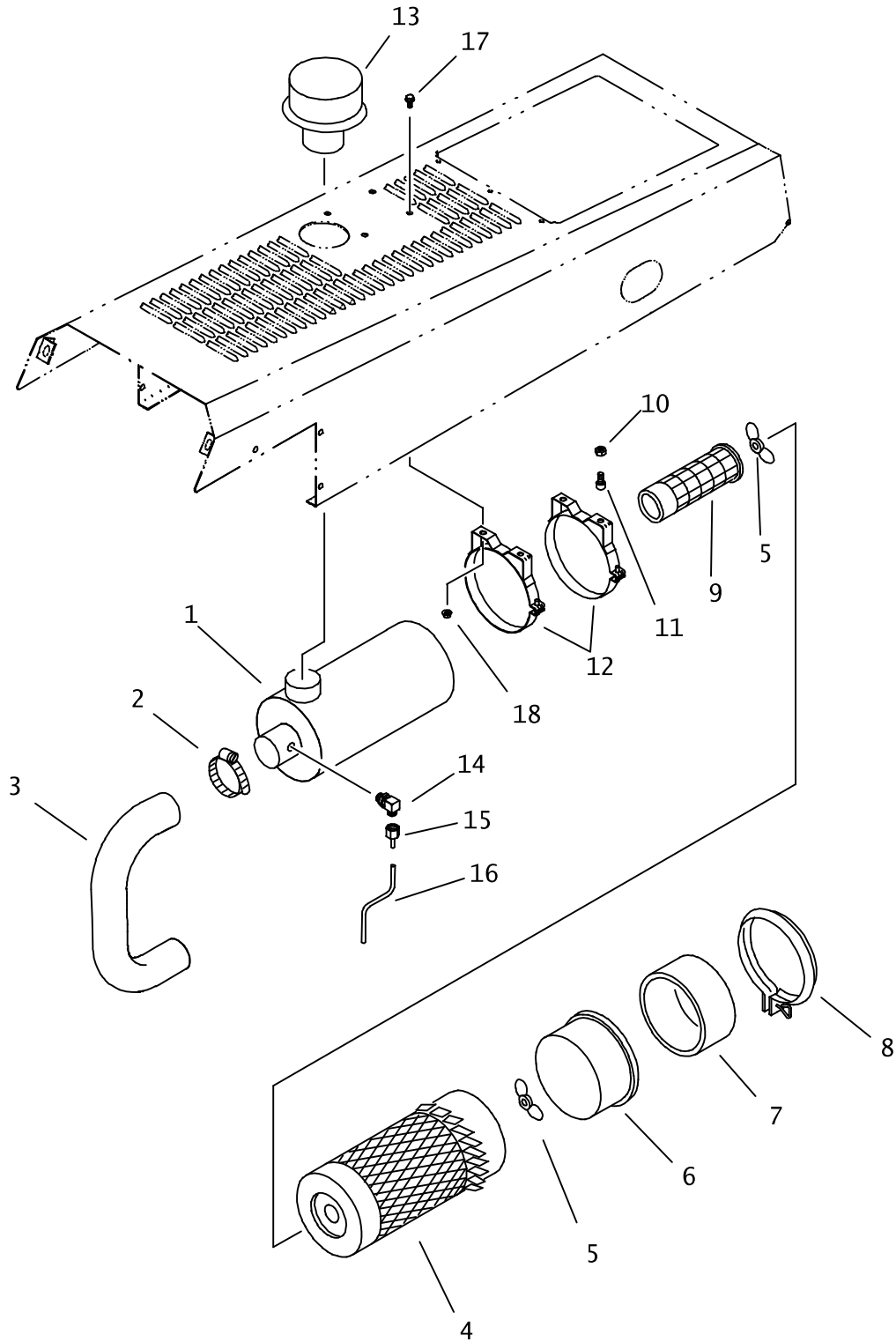

AIR FILTER SYSTEM

REF NO.	PART NUMBER	QTY	DESCRIPTION	REMARKS
1.	195-816	1	AIR CLEANER	
2.	110-311	2	WORM CLAMP (1-5/16" TO 3-1/4")	
3.	116-586	1	AIR INTAKE HOSE	
4.	195-817	1	AIR CLEANER ELEMENT	
5.	195-815	2	WING NUT (7/16 NF)	
6.	195-641	1	BAFFEL	
7.	195-824	1	BOTTOM CUP	
8.	195-642	1	CLAMP 6-1/2"	
9.	195-818	1	SAFETY ELEMENT	
10.	106-175	4	HEX NUT (M10-1.50) 10 2P	
11.	106-654	4	SCREW (M10-1.50 X 16)	
12.	195-656	2	MOUNTING CLAMP (6-1/2")	
13.	195-692	1	STACK CAP	
14.	156-228	1	ELBOW (20N90)	
15.	155-150	1	SLIP-ON COUPLER	
16.	116-192	AR	BULK HOSE (3MM ID) BULK HOSE (7/64" ID)	SOLD PER 25.4MM SOLD PER 1"
17.	106-380	4	FLG LK NUT (M8-1.25)	
18.	105-386	4	FLG LK SCREW (M8-1.25 X 16MM)	

NOT SHOWN:

FOOTNOTES:

NOTE:

RADIATOR

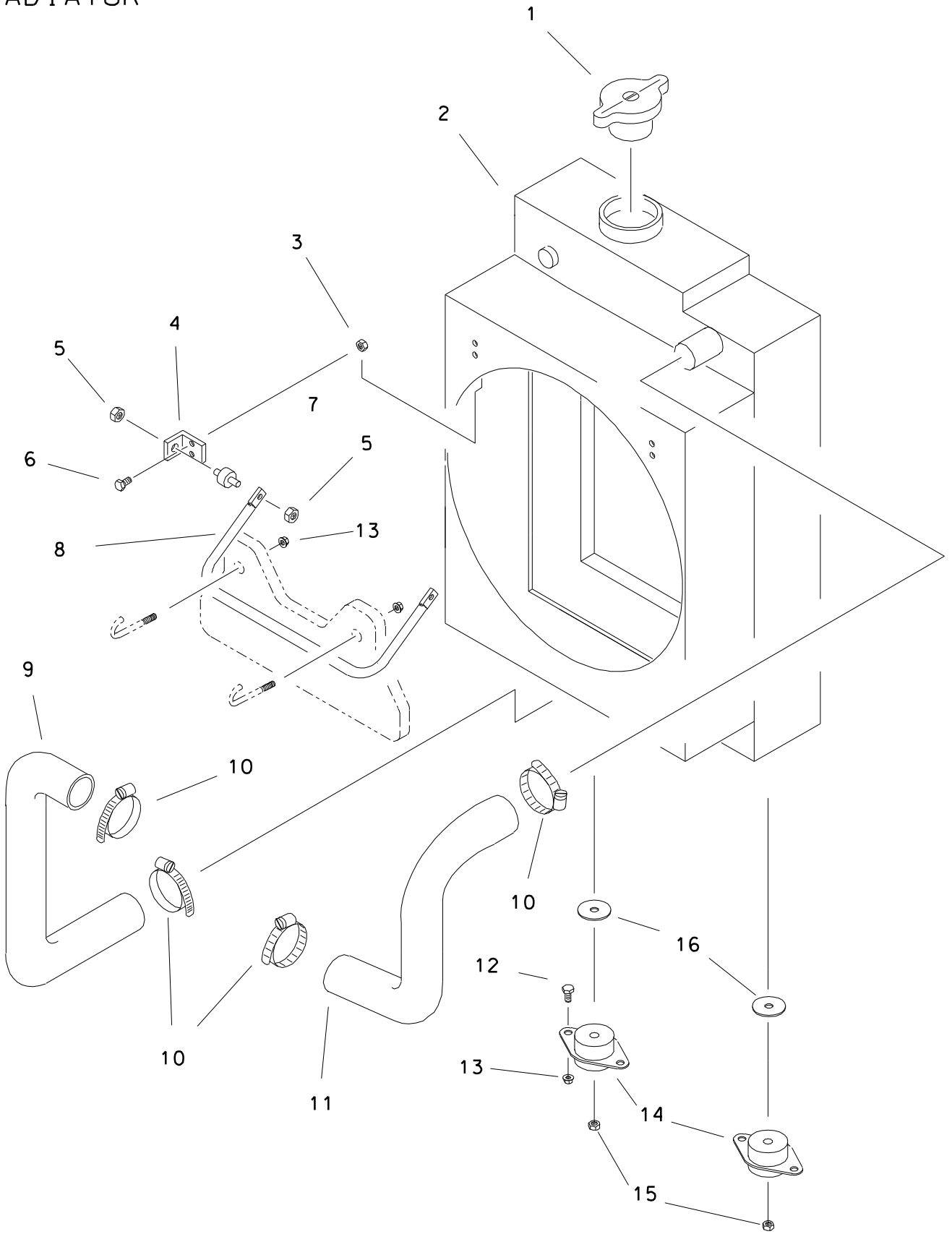

RADIATOR

REF NO.	PART NUMBER	QTY	DESCRIPTION	REMARKS
1.	159-137	1	RADIATOR CAP (2.23", 13PSI)	
2.	360-383	1	OIL COOLER AND RADIATOR	
-	306-829	-	OIL COOLER	
-	306-830	-	RADIATOR	
3.	106-385	4	FLG LOCKNUT (M6-1.00)	
4.	363-506	2	RADIATOR STAY BRACKET	
5.	105-078	4	NUT (1/4-NC)	
6.	106-161	4	FLG LOCK SCREW (M6-1.00 X 20mm)	
7.	116-540	2	SHEAR MOUNT	
8.	353-746	1	RADIATOR STAY	
9.	116-543	1	LOWER COOLANT HOSE	
10.	110-133	4	WORM CLAMP (1.062" TO 1.937")	
11.	116-542	1	UPPER COOLANT HOSE	
12.	106-083	4	SCREW (M8-1.25 X 20mm)	
13.	106-386	6	FLG LOCKNUT (M8-1.25)	
14.	116-539	2	ISOLATOR	
15.	105-845	2	FLG LOCKNUT (3/8-NC)	
16.	105-071	2	WASHER (1/2")	

FOOTNOTES

FLUID SYSTEMS

HYDRAULIC SCHEMATIC ENDS W/ SN 2M1669

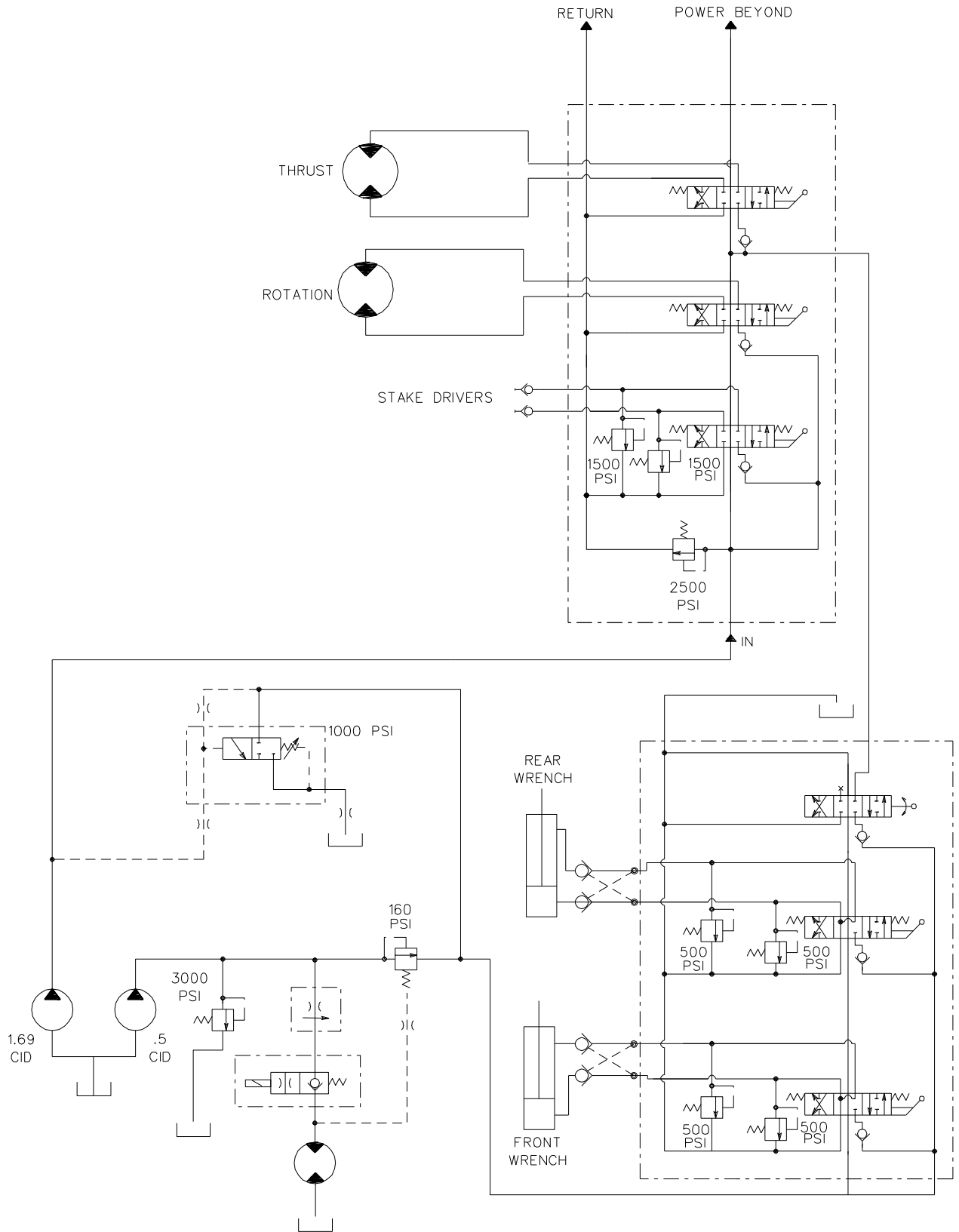

HYDRAULIC SCHEMATIC

ENDS W/ SN 2M1669

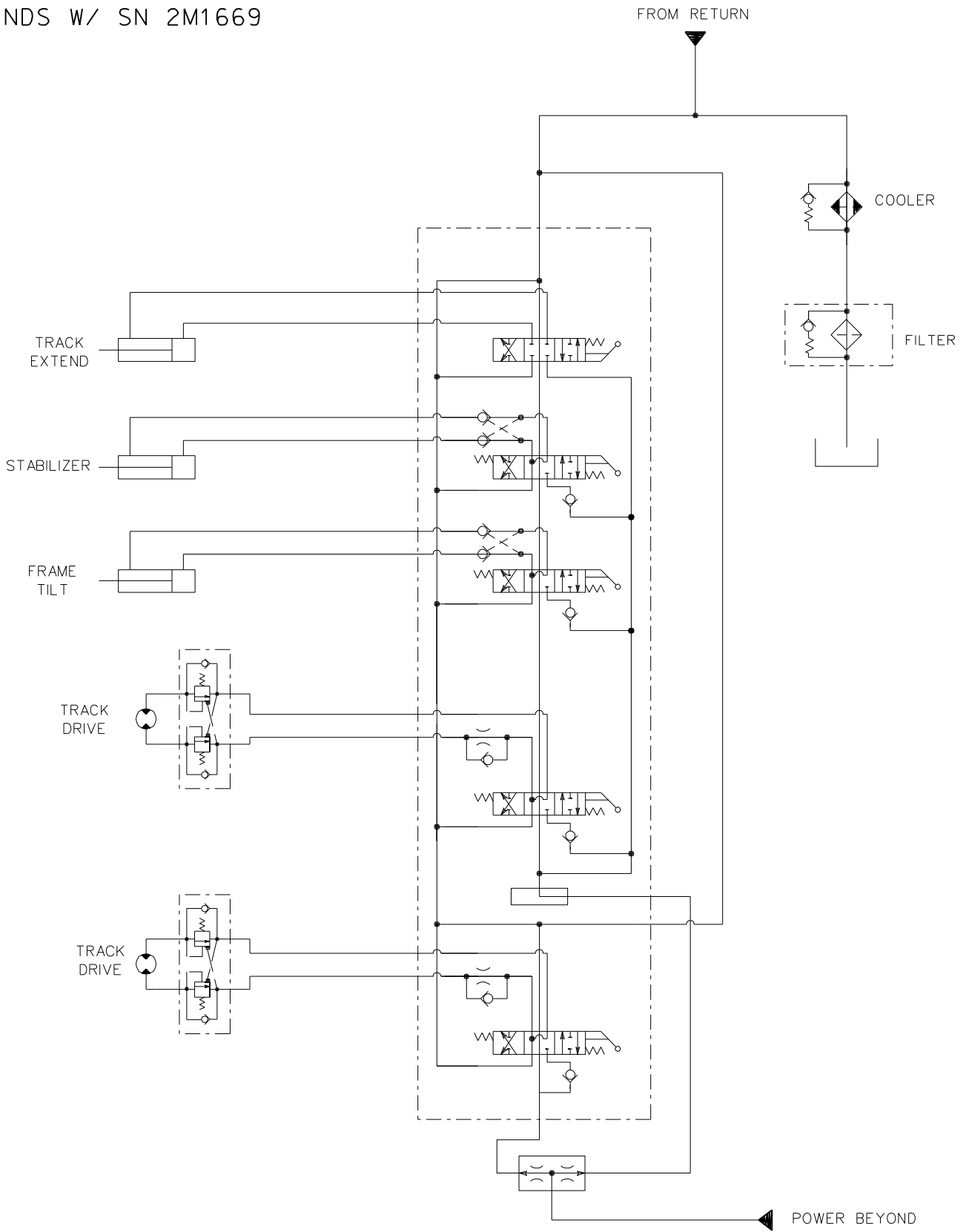

HYDRAULIC SCHEMATIC
ENDS W/ SN 2M1669

SPECIFICATIONS

ENGINE		PUMP			MOTOR	
MFG (NO LOAD)	RPM	TYPE	GPM	DISPLACEMENT	TYPE	DISPLACEMENT
<i>LISTER - PETTER LPWS4</i>	<i>2500</i>	<i>ROTATION THRUST</i>	<i>18.3 5.4</i>	<i>1.69 .50</i>	<i>ROTATION THRUST GROUND DRIVE</i>	<i>19 38.4 32.2</i>

HYDRAULIC SCHEMATIC BEGINS W/ SN 2M1670

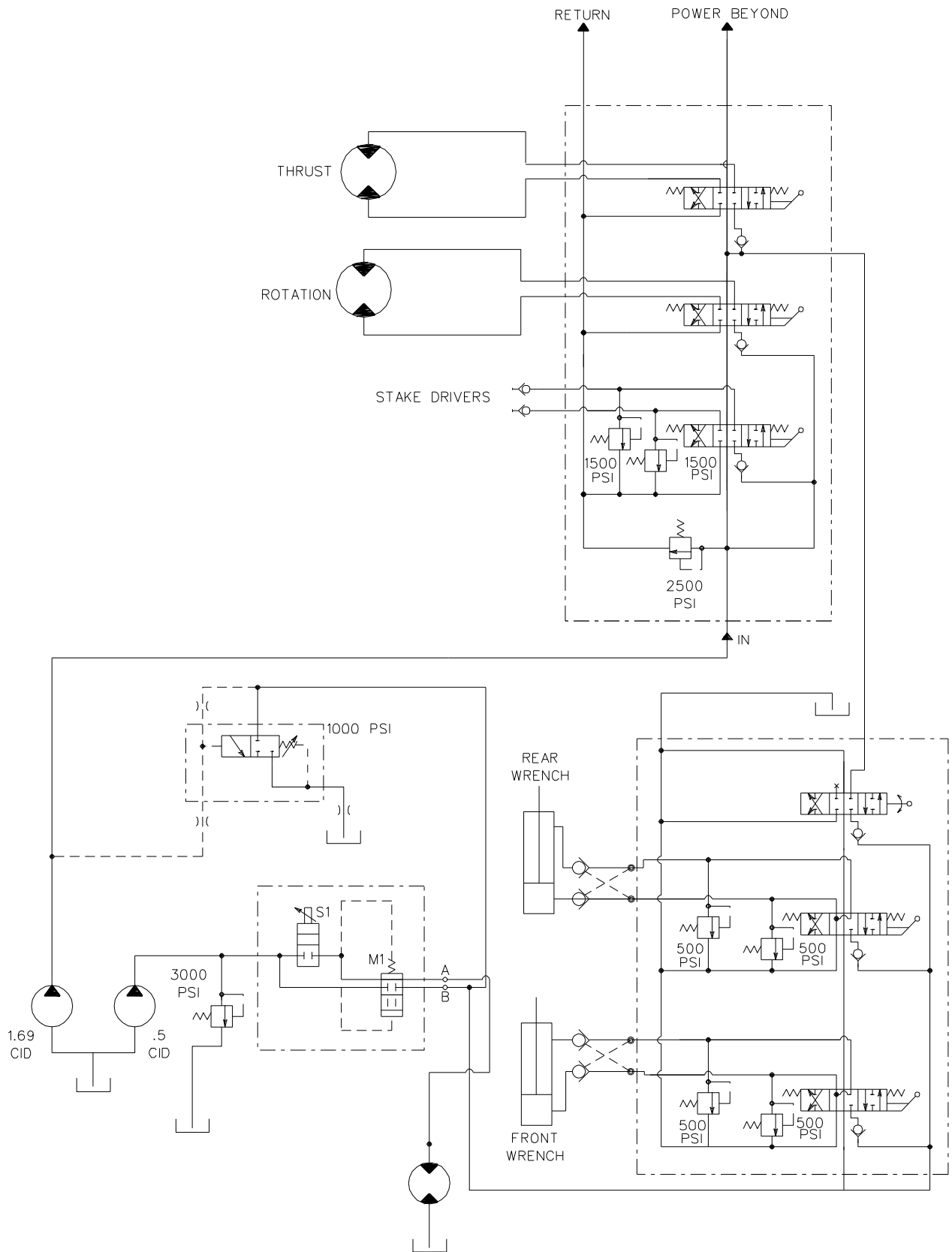

HYDRAULIC SCHEMATIC

BEGINS W/ SN 2M1670

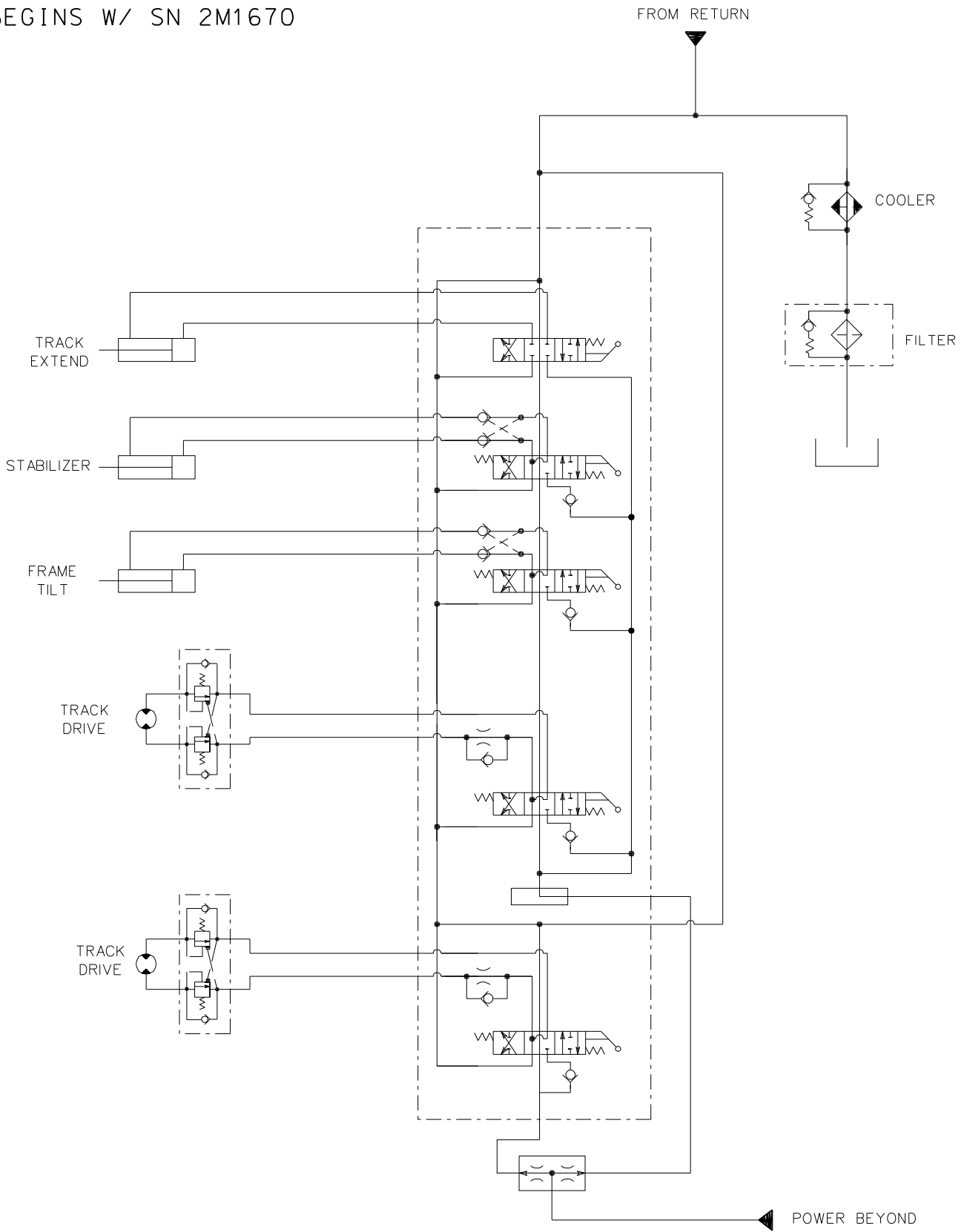

HYDRAULIC SCHEMATIC
 BEGINS W/ SN 2M1670

SPECIFICATIONS

ENGINE		PUMP			MOTOR	
MFG (NO LOAD)	RPM	TYPE	GPM	DISPLACEMENT	TYPE	DISPLACEMENT
<i>LISTER - PETTER LPWS4</i>	<i>2500</i>	<i>ROTATION THRUST</i>	<i>18.3 5.4</i>	<i>1.69 .50</i>	<i>ROTATION THRUST GROUND DRIVE</i>	<i>19 38.4 32.2</i>

HYDRAULIC RESERVOIR

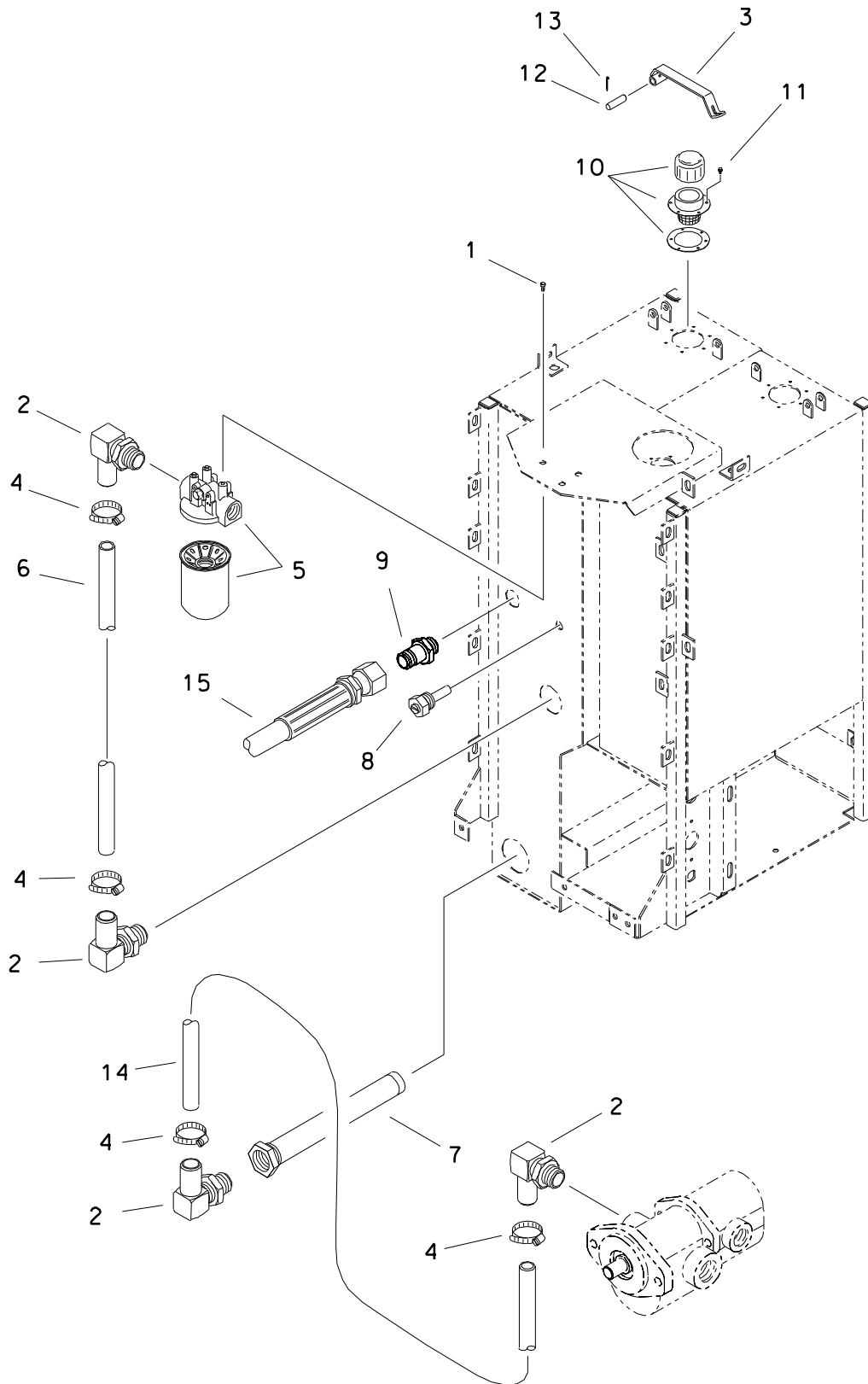

HYDRAULIC RESERVOIR

REF NO.	PART NUMBER	QTY	DESCRIPTION	REMARKS
1.	105-825	3	FLG LK BOLT (3/8-NC X 3/4")	
2.	155-168	4	S/O CPLR (20S-20H90)	
3.	364-212	1	HYD LOCK STRAP	
4.	110-133	4	WORM CLAMP (27MM TO 49MM) WORM CLAMP (1-1/16" TO 1-15/16")	
5.	159-081 159-079	1	HYD OIL FILTER ELEMENT (1-1/2-UNF)	
6.	116-587	AR	BULK HOSE (32MM ID-13BAR) BULK HOSE (1.250" ID-187PSI)	SOLD PER 305MM-USE 495MM SOLD PER 1 FT-USE 19.5"
7.	110-336	1	STRAINER	
8.	215-148	1	TEMPERATURE SWITCH	
9.	154-233	1	CONNECTOR (08S-080)	
10.	110-008 165-626	1	FILLER BREATHER (2-1/8") GASKET	
11.	105-214	6	SCREW (#10-24 X 1/2", FLG HEX)	
12.	183-978	1	PIN	
13.	105-535	1	ROLL PIN (1/8" X 5/8")	
14.	116-587	AR	BULK HOSE (32MM ID-13BAR) BULK HOSE (1.250" ID-187PSI)	SOLD PER 305MM-USE 216MM SOLD PER 1 FT-USE 8.5"
15.	154-942	1	HOSE (080FX90-330MM-207BAR) HOSE (080FX90-13"-3000PSI)	

FOOTNOTES

REFER TO O-RING CHART (800-301) IN BACK OF THE BOOK FOR REPLACEMENT OF SAE AND ORS O-RINGS.

OIL COOLER HYDRAULICS

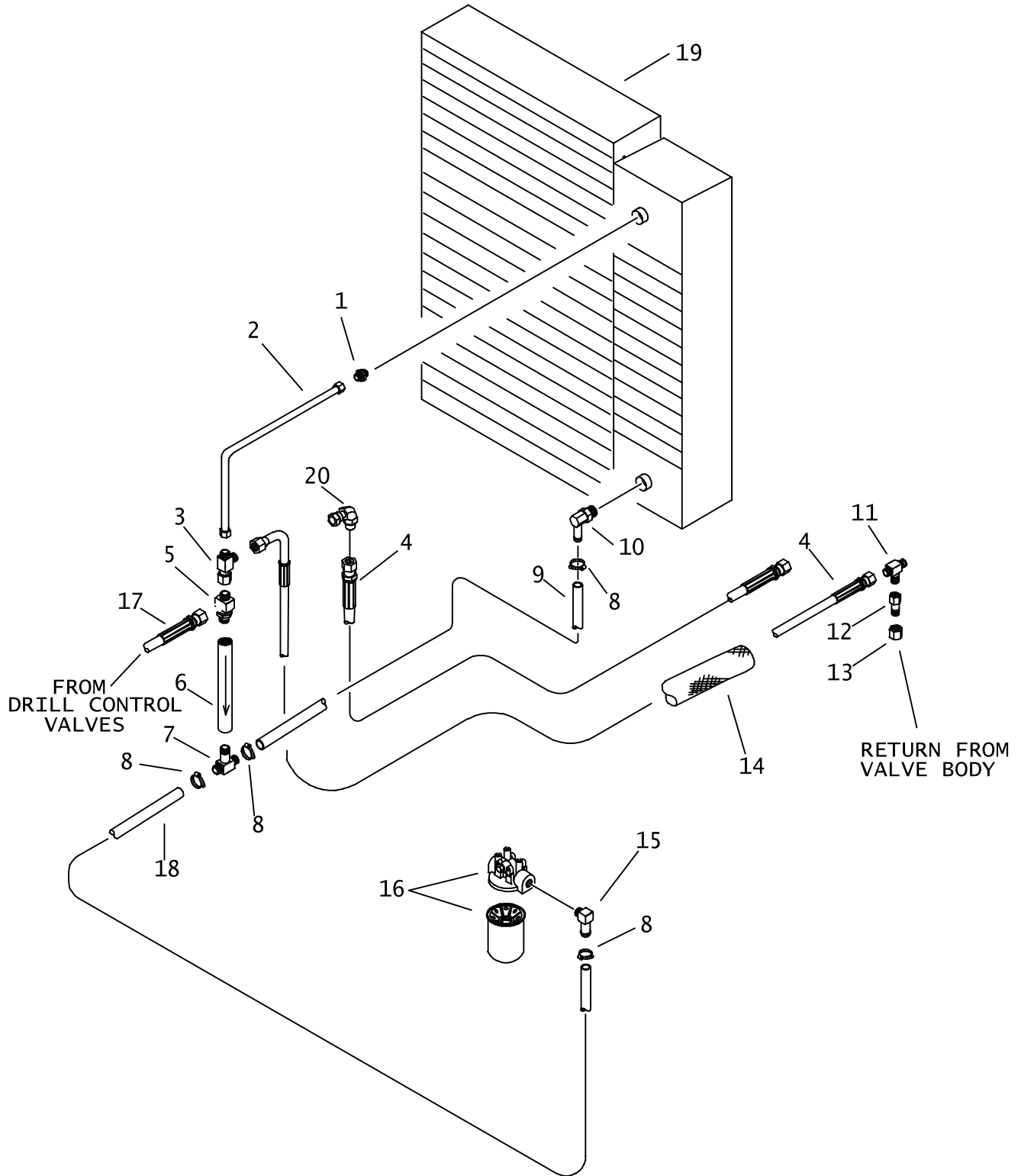

OIL COOLER HYDRAULICS

REF NO.	PART NUMBER	QTY	DESCRIPTION	REMARKS
1.	154-269	1	CONNECTOR (12S-120)	
2.	156-563	1	HYD LINE (-12)	
3.	154-368	1	UNION RUN TEE (120FX-120-120)	
4.	515-242	1	HOSE (120FX90-95"-3000)	WITH WATER TANK. USE WITH JT920 & JT921
	515-230	1	HOSE (120FX-54"-4000)	WITHOUT WATER TANK. USE WITH JT921S
5.	154-292	1	RUN TEE (12S-120-120)	
6.	158-576	1	CHECK VALVE (12SF-12SF)	ENDS WITH S/N 2N1740
	155-245	-	FLOW CHECK VALVE (12SF-12SF)	BEGINS WITH S/N 2N1741
7.	514-043	1	S/O BR TEE (12S-20H-20H)	
8.	110-133	4	WORM CLAMP (1-1/6" - 1-15/16")	
9.	116-587	AR	BULK HOSE (1.250", SOLD PER 1")	USE 17"
10.	514-027	1	S/O COUPLER (12S-20H90)	
11.	154-368	1	UNION RUN TEE (120FX-120-120)	
12.	154-249	1	REDUCER STEM (080)	
13.	154-271	1	REDUCER NUT (120F)	
14.	115-924	1	ABRASION SLEEVE (1.59" X 88")	
	115-903	1	ABRASION SLEEVE (1.59" X 50")	
15.	155-168	1	SLIP-ON COUPLER (20S-20H90)	
16.	159-081	1	HYDRAULIC OIL FILTER (20SF-20SF)	WITH WATER TANK
	159-079	1	FILTER ELEMENT (1-1/2-UNF)	WITHOUT WATER TANK
17.	515-218	1	HOSE 120FX90-80"-3000)	
18.	116-587	AR	BULK HOSE ((1.250", SOLD PER 1")	USE 65"
19.	360-383	-	RADIATOR/OIL COOLER	
	306-829	-	OIL COOLER	
	306-830	-	RADIATOR	
20.	154-457	1	UNION (120-120FX90)	WITHOUT WATER TANK. USE WITH JT921S

FOOTNOTES

NOTE:

REFER TO O-RING CHART (800-30I) IN BACK OF THE BOOK FOR REPLACEMENT OF O-RINGS.

L

804-026

DRIVE CONTROL VALVE & LEVERS

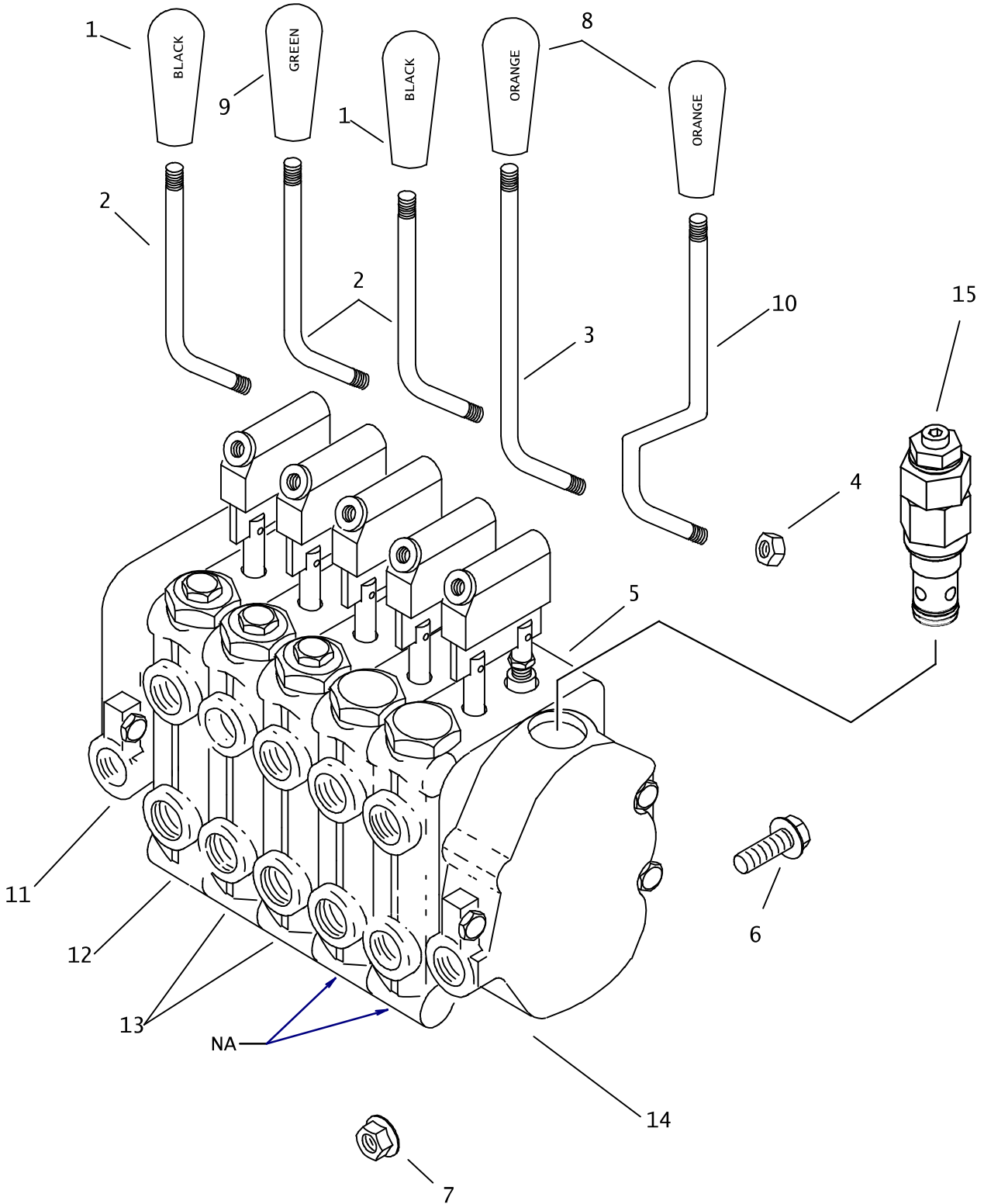

DRIVE CONTROL VALVE & LEVERS

REF NO.	PART NUMBER	QTY	DESCRIPTION	REMARKS
1.	110-531	2	HANDLE (1/2-NC, BLACK)	
2.	353-140	3	CONTROL LEVER	USE 242 LOCTITE
3.	353-141	1	CONTROL LEVER	USE 242 LOCTITE
4.	105-044	5	JAM NUT (1/2-NC)	
5.	158-937	1	HYD CONTROL VALVE (_-SPOOL)	
6.	105-827	3	FLG LK BOLT (3/8-NC X 1-1/4")	BEGIN WITH S/N 2N2402
7.	105-845	3	FLG LOCKNUT (3/8-NC)	
8.	110-465	2	KNOB (1/2-NC, ORANGE)	
9.	110-530	1	HANDLE (1/2-NC, GREEN)	
10.	353-311	1	CONTROL LEVER	USE 242 LOCTITE
11.	500-565	-	OUTLET COVER.	
12.	500-559	-	VALVE SECTION (#V12W-1FBCAS)	
13.	500-558	-	VALVE SECTION (#V12W-1FBCJLEE)	
14.	500-556	-	INLET COVER	
15.	150-1064	1	PILOT OPERATED RELIEF (ADI, 1850 PSI)	BEGINS WITH S/N 2zi825

NOT SHOWN:

FOOTNOTES:

NOTE:

CONTROL VALVES & LEVERS

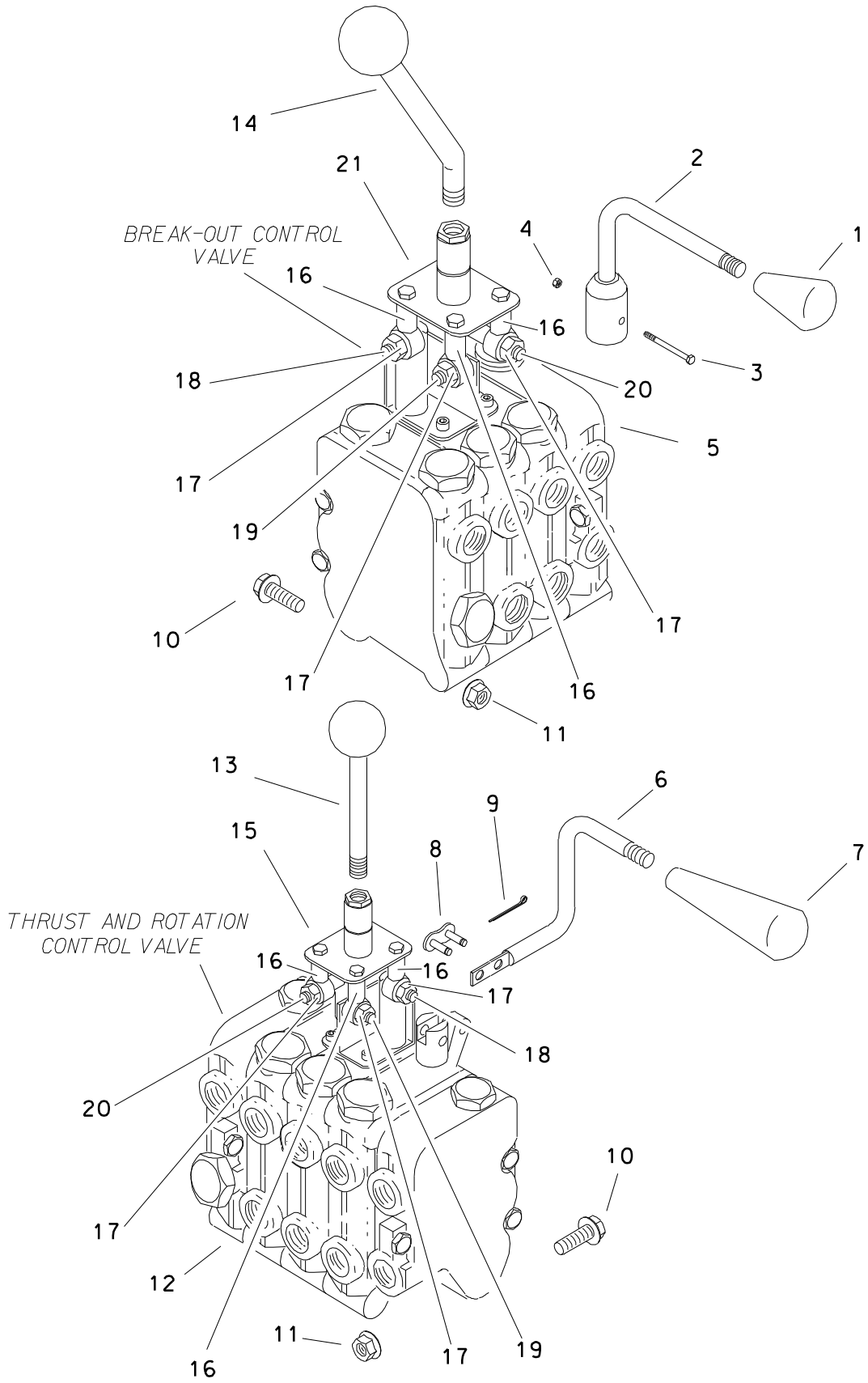

CONTROL VALVES & LEVERS

REF NO.	PART NUMBER	QTY	DESCRIPTION	REMARKS
1.	110-283	1	KNOB (3/8-NC, BLACK)	
2.	361-736	1	LEVER	
3.	105-856	1	BOLT (1/4-NC X 1-1/4")	
4.	105-085	1	NUT (1/4-NC)	
5.	158-856	1	HYDRAULIC CONTROL VALVE	
6.	355-595	1	LEVER	
7.	110-637	1	HANDLE (1/2-NC, YELLOW)	
8.	500-419	1	CONNECTOR LINK	
9.	105-530	1	COTTER PIN (1/16" X 3/4")	
10.	106-206	6	SCREW (M8-1.25 X 70mm)	
11.	106-386	6	FLG LK NUT (M8-1.25)	
12.	158-800	1	HYDRAULIC CONTROL VALVE	
13.	500-912	1	STRAIGHT JOYSTICK LEVER	
14.	500-911	1	OFFSET JOYSTICK LEVER	
15.	500-965	1	L.H. JOYSTICK TOWER	
16.	110-575	3	ROD END	
17.	105-213	3	LOCKNUT	
18.	499-020	1	'STUD', ROD END	
19.	499-019	1	'SCREW', ROD END	
20.	499-018	1	'SLIDE', ROD END	
21.	217-271	1	R.H. JOYSTICK TOWER	

NOT SHOWN:
 499-021 3 SPACERS

FOOTNOTES

GROUND DRIVE HYDRAULICS

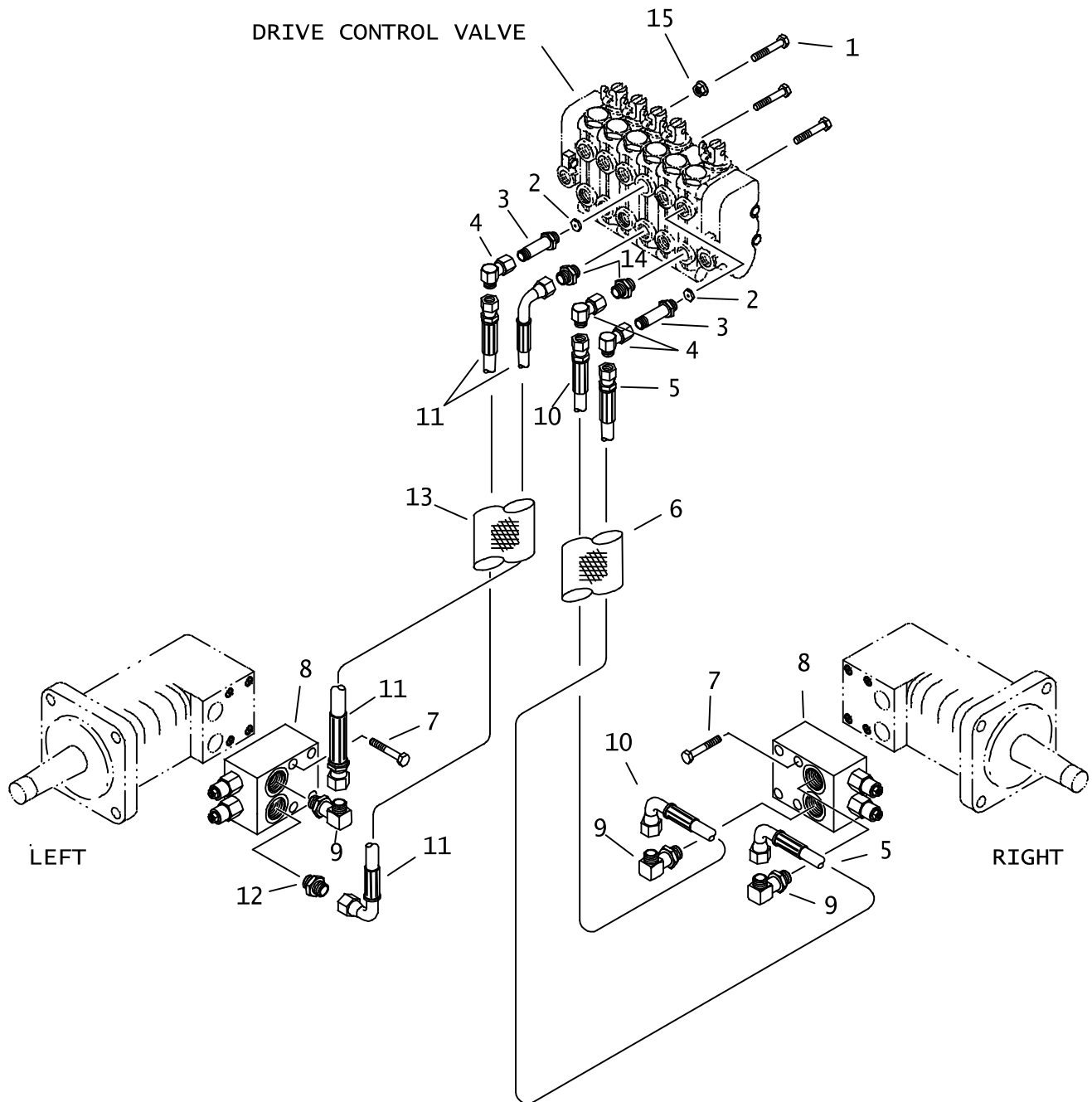

GROUND DRIVE HYDRAULICS

REF NO.	PART NUMBER	QTY	DESCRIPTION	REMARKS
1.	105-827	3	FLG LK BOLT (3/8-NC X 1-1/4")	
2.	516-006	2	ORFICE, WORK PORT	ENDS W/ SN 2M2002
3.	154-438	2	CONNECTOR (08S-080)	
4.	154-256	3	UNION (080-080FX90)	
5.	515-141	1	HOSE (080FX90-2083MM-207BAR)	WITH WATER TANK
			HOSE (080FX90-66"-3000PSI)	
	515-192	1	HOSE (080FX90-1372MM-207BAR)	WITHOUT WATER TANK
			HOSE (080FX90-54"-3000PSI)	
6.	115-817	1	ABRASION SLEEVE (1.59" X 84")	WITH WATER TANK
			ABRASION SLEEVE (41MM X 2134MM)	
	115-903	1	ABRASION SLEEVE (41MM X 1270MM)	WITHOUT WATER TANK
			ABRASION SLEEVE (1.59" X 50")	
7.	105-178	8	BOLT (5/16-NC X 2-1/2",GD8)	
8.	159-302	2	COUNTERBALANCE MANIFOLD	
	500-819	4	COUNTERBALANCE CARTRIDGE KIT	
9.	154-322	3	CONNECTOR (10S-08090)	
10.	515-241	1	HOSE (080FX90-2083MM-207BAR)	WITH WATER TANK
			HOSE (080FX90-82"-3000PSI)	
	515-191	1	HOSE (080FX90-1372MM-207BAR)	WITHOUT WATER TANK
			HOSE (080FX90-54"-3000PSI)	
11.	515-243	2	HOSE (080FX90-1676MM-207BAR)	WITH WATER TANK
			HOSE (080FX90-66"-3000PSI)	
	515-191	2	HOSE (080FX90-1372MM-207BAR)	WITHOUT WATER TANK
			HOSE (080FX90-54"-3000PSI)	
12.	154-279	1	CONNECTOR (080-10S)	
13.	115-924	1	ABRASION SLEEVE (41MM X 2235MM)	WITH WATER TANK
			ABRASION SLEEVE (1.59" X 88")	
	115-903	1	ABRASION SLEEVE (1.59" X 50")	WITHOUT WATER TANK
			ABRASION SLEEVE (41MM X 1270MM)	
14.	154-233	2	CONNECTOR (08S-080)	
15.	105-845	3	FLG LOCKNUT (3/8-NC)	

NOT SHOWN:

FOOTNOTES:

NOTE:

REFER TO O-RING CHART (800-301) IN BACK OF THE BOOK FOR REPLACEMENT OF SAE AND ORS O-RINGS.

TRACK EXTEND HYDRAULICS

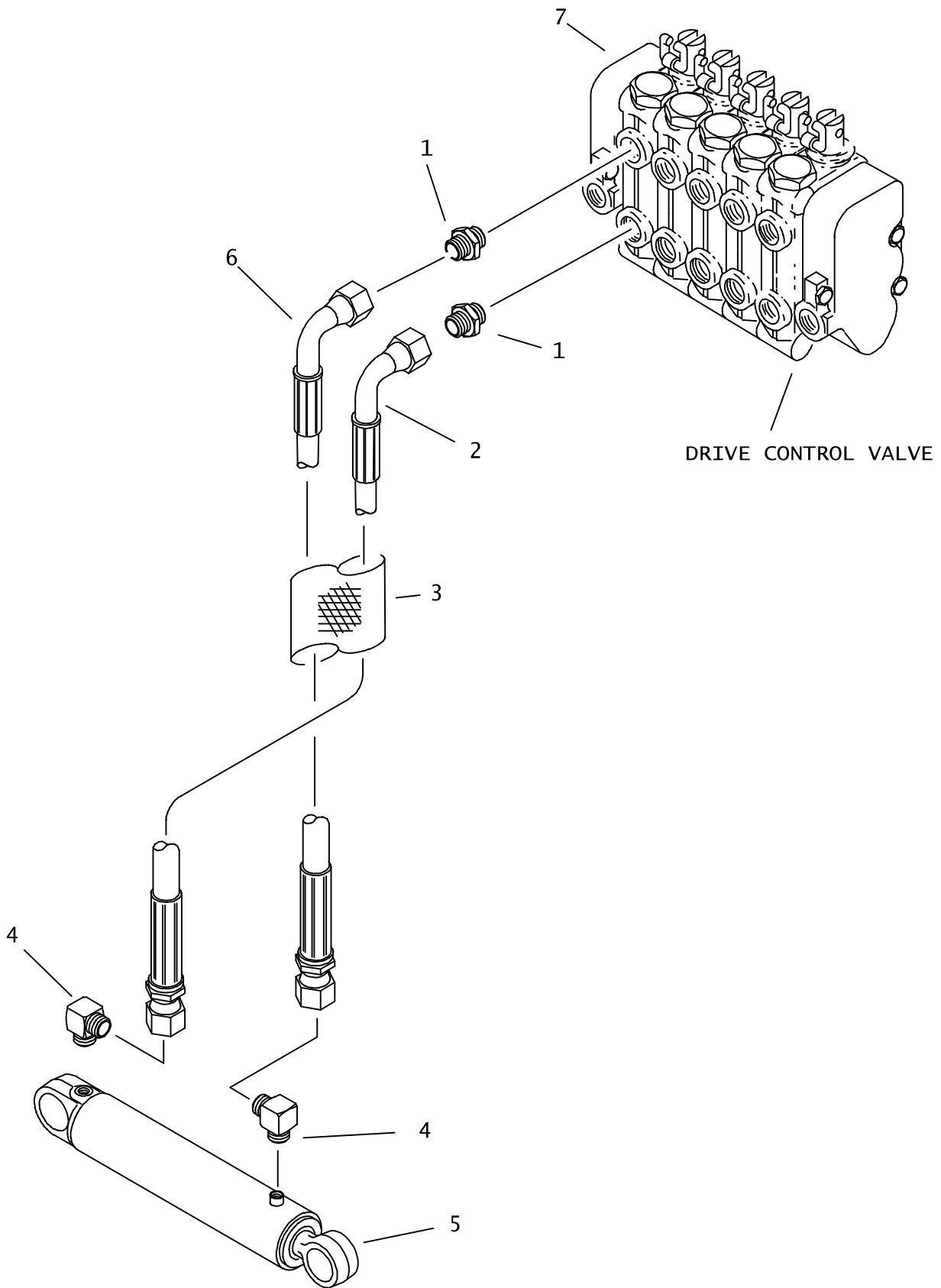

TRACK EXTEND HYDRAULICS

REF NO.	PART NUMBER	QTY	DESCRIPTION	REMARKS
1.	154-261	2	CONNECTOR (040-08S)	
2.	155-488	1	HOSE (040FX90-106"-3000)	WITH WATER TANK
	515-074	1	HOSE(040FX90-77"-3000)	WITHOUT WATER TANK
3.	115-902	1	ABRASION SLEEVE (1.59" X 100")	WITH WATER TANK
	115-935	1	ABRASION SLEEVE (1.75" X 70")	WITHOUT WATER TANK
4.	154-252	2	CONNECTOR (04S-04090)	
5.	151-076	1	CYL (2.0" X 1.00" X 10.00")	
6.	154-771	1	HOSE (040FX90-110"-3000)	WITH WATER TANK
	515-074	1	HOSE (040FX90-77"-3000)	WITHOUT WATER TANK
7.	158-937	-	HYD CONTROL VALVE (-SPOOL)	BEGINS WITH S/N 2N2402

NOT SHOWN:

FOOTNOTES:

NOTE:

REFER TO O-RING CHART (800-301) IN BACK OF THE BOOK FOR REPLACEMENT OF O-RINGS

STABILIZER JT820/JT920

DRIVE CONTROL VALVE

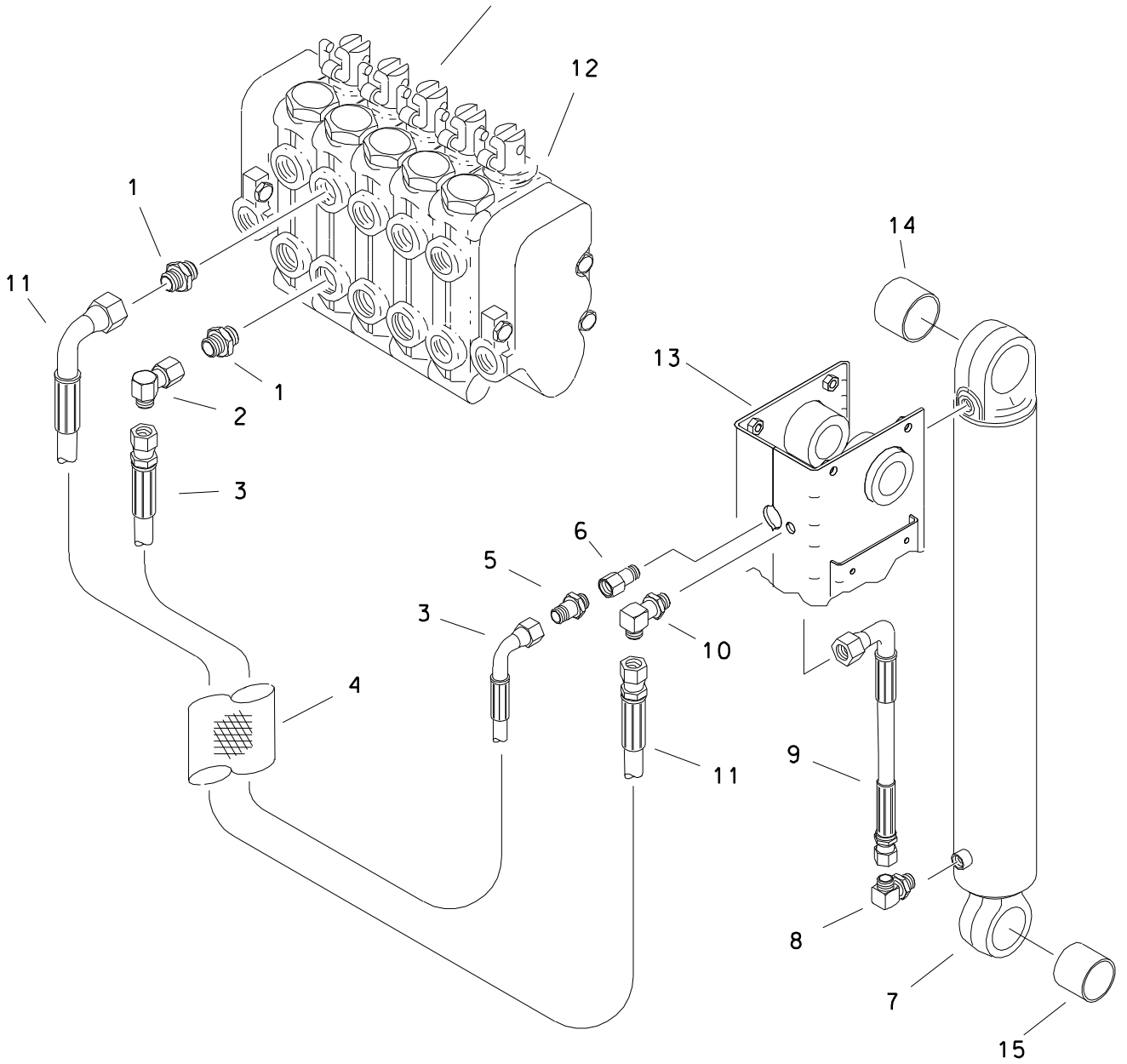

STABILIZER JT820/JT920

REF NO.	PART NUMBER	QTY	DESCRIPTION	REMARKS
1.	154-261	2	CONNECTOR (040-08S)	
2.	154-255	1	UNION (040-040FX90)	
3.	515-240	1	HOSE (040FX90-72"-3000)	
	515-210	1	HOSE (040FX90-28"-3000)	WITH WATER TANK
	515-010	1	HOSE (040FX90-32"-3000)	WITHOUT WATER TANK
4.	115-935	1	ABRASION SLEEVE (1.75" X 70")	WITHOUT WATER TANK
	115-754	1	ABRASION SLEEVE (1.59" X 30")	WITH WATER TANK
5.	154-403	1	CONNECTOR (04S-040, XL)	WITHOUT WATER TANK
6.	155-254	1	REDUCER (06S-04SF)	
7.	151-117	1	CYL (3" X 1.5" X 20")	ENDS WITH S/N2W2287
	151-147	1	CYL (3" X 1.5" X 20")	BEGINS WITH S/N2W2288
8.	154-226	1	CONNECTOR (040-06S90)	
9.	154-743	1	HOSE (040FX90-23"-3000)	
10.	154-355	1	BK CONNECTOR (040-04090BK)	
11.	515-074	1	HOSE (040FX90-77"-3000)	
12.	158-937	-	HYD CONTROL VALVE (1-SPOOL)	BEGINS WITH S/N 2N2402
	158-801	-	HYD CONTROL VALVE (5-SPOOL)	ENDS WITH S/N 2N2401
13.	353-289	-	UPPER STABILIZER TUBE	
	353-290	-	UPPER STABILIZER TUBE-WET	
14.	125-773	1	COMPOSITION BUSHING (1.75")	
15.	125-772	1	COMPOSITION BUSHING (1.5")	

FOOTNOTES

REFER TO O-RING CHART (800-301) IN BACK OF THE BOOK FOR REPLACEMENT OF O-RINGS.

FRAME TILT

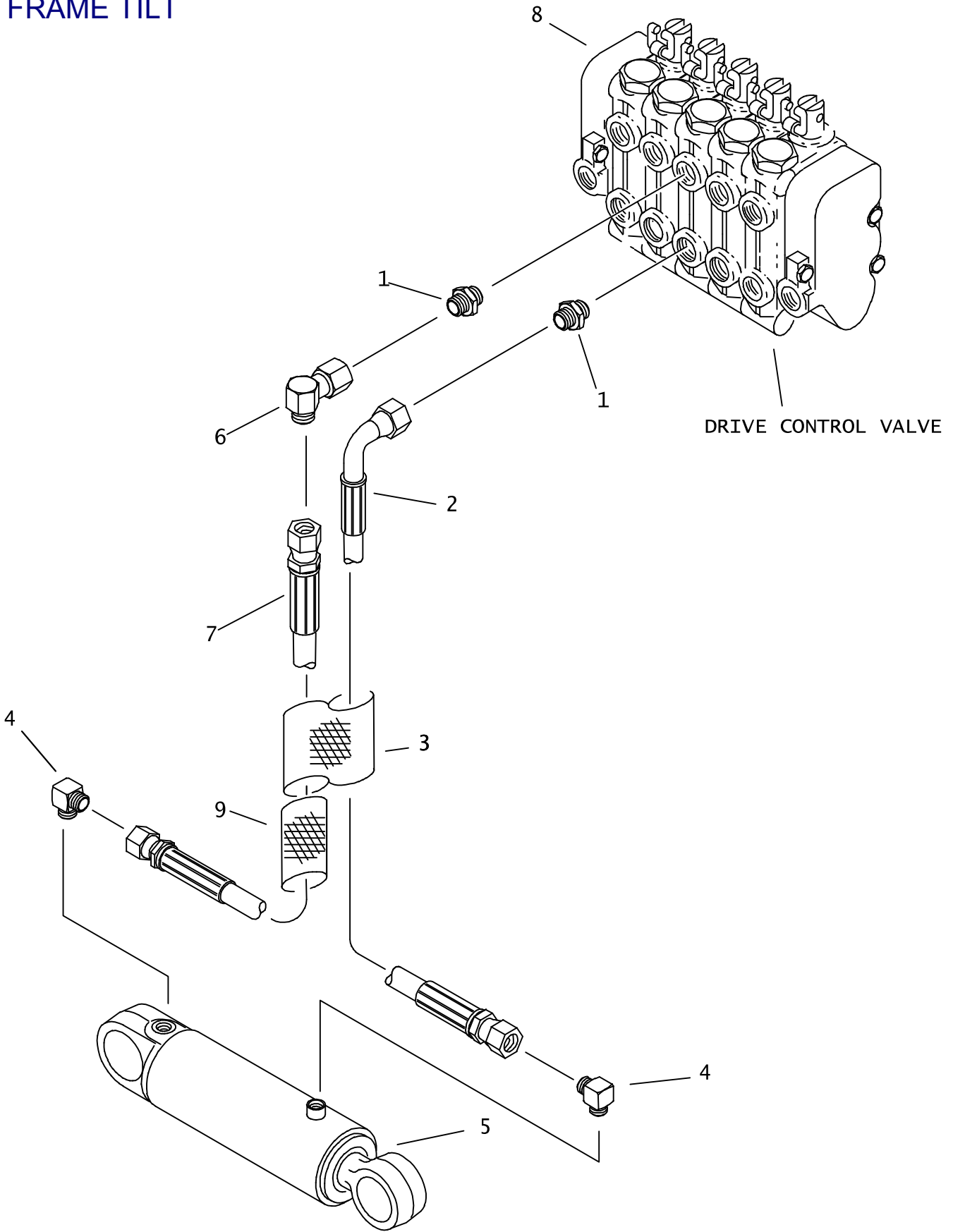

FRAME TILT

REF NO.	PART NUMBER	QTY	DESCRIPTION	REMARKS
1.	154-261	2	CONNECTOR (040-08S)	
2.	515-239	1	HOSE (040FX90-116"-3000)	WITH WATER TANK. USE WITH JT920 & 921
	154-933	1	HOSE (040FX90-94"-3000)	WITHOUT WATER TANK. USE WITH JT921S
3.	116-633	1	ABRASION SLEEVE (1.59" X 115")	WITH WATER TANK. USE WITH JT920 & JT921
	116-787	1	ABRASION SLEEVE (1.59" X 95")	WITHOUT WATER TANK. USE WITH JT921S
4.	154-226	2	CONNECTOR (040-06S90)	WITHOUT WATER TANK. USE WITH JT921S
5.	151-054	1	CYL (3.0" X 1.50" X 4.000")	
6.	154-255	1	UNION (040-040FX90)	WITH WATER TANK. USE WITH JT920 & JT921
7.	154-742	1	HOSE (040FX-130"-3000)	WITH WATER TANK. USE WITH JT920 & JT921S
	155-488	1	HOSE (040FX90-106"-3000)	WITHOUT WATER TANK. USE WITH JT921S
8.	158-937	-	HYD CONTROL VALVE (1-SPOOL)	BEGINS WITH S/N 2N2402
	158-801	-	HYD CONTROL VALVE (5-SPOOL)	ENDS WITH S/N 2N2401
9.	117-194	1	ABRASION SLEEVE (1.00" X 16")	

NOT SHOWN:

FOOTNOTES:

NOTE:

REFER TO O-RING CHART (800-301) IN BACK OF THE BOOK FOR REPLACEMENT OF O-RINGS.

ANCHOR DRIVER HYDRAULICS

THRUST AND ROTATION
CONTROL VALVE

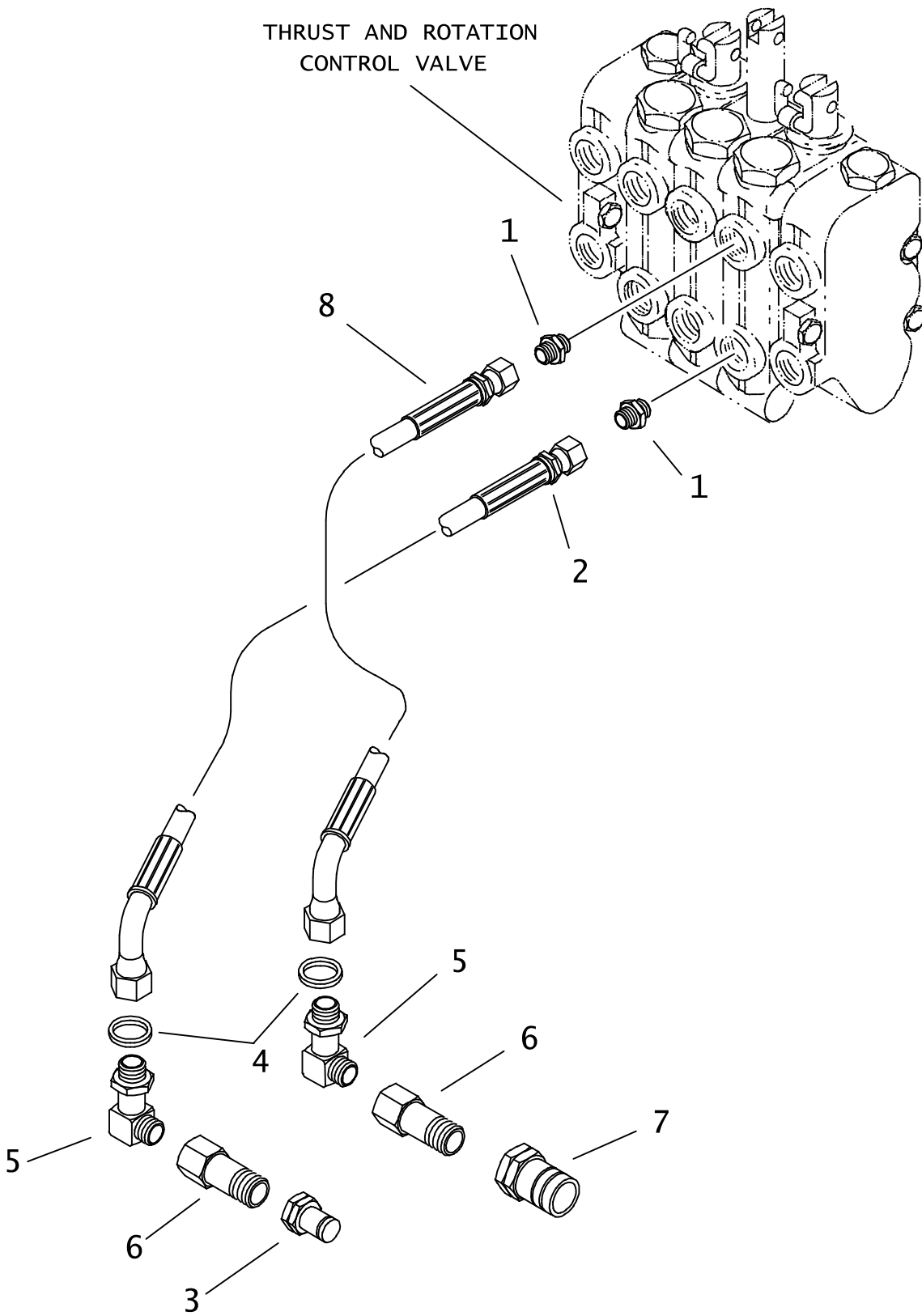

ANCHOR DRIVER HYDRAULICS

REF NO.	PART NUMBER	QTY	DESCRIPTION	REMARKS
1.	154-233	2	CONNECTOR (08S-080)	
2.	515-182	1	HOSE (080FX45-356MM-207BAR) HOSE (080FX45-14"-3000PSI)	
3.	159-030	1	QDC ADAPTER (08-08SF)	
4.	105-423	2	WASHER (3/4")	
5.	154-396	2	BK CONNECTOR (080-08090BK)	
6.	156-732	2	CONNECTOR (080FX TO 08JIC M)	
7.	159-029	1	QDC BODY (08-09SF)	
8.	515-212	1	HOSE (080-08045M-381MM-207BAR) HOSE (080FX45M-15"-3000PSI)	

NOT SHOWN:

FOOTNOTES:

NOTE:

REFER TO O-RING CHART (800-301) IN BACK OF THE BOOK FOR REPLACEMENT OF SAE AND ORS O-RINGS.

CARRIAGE THRUST HYDRAULICS

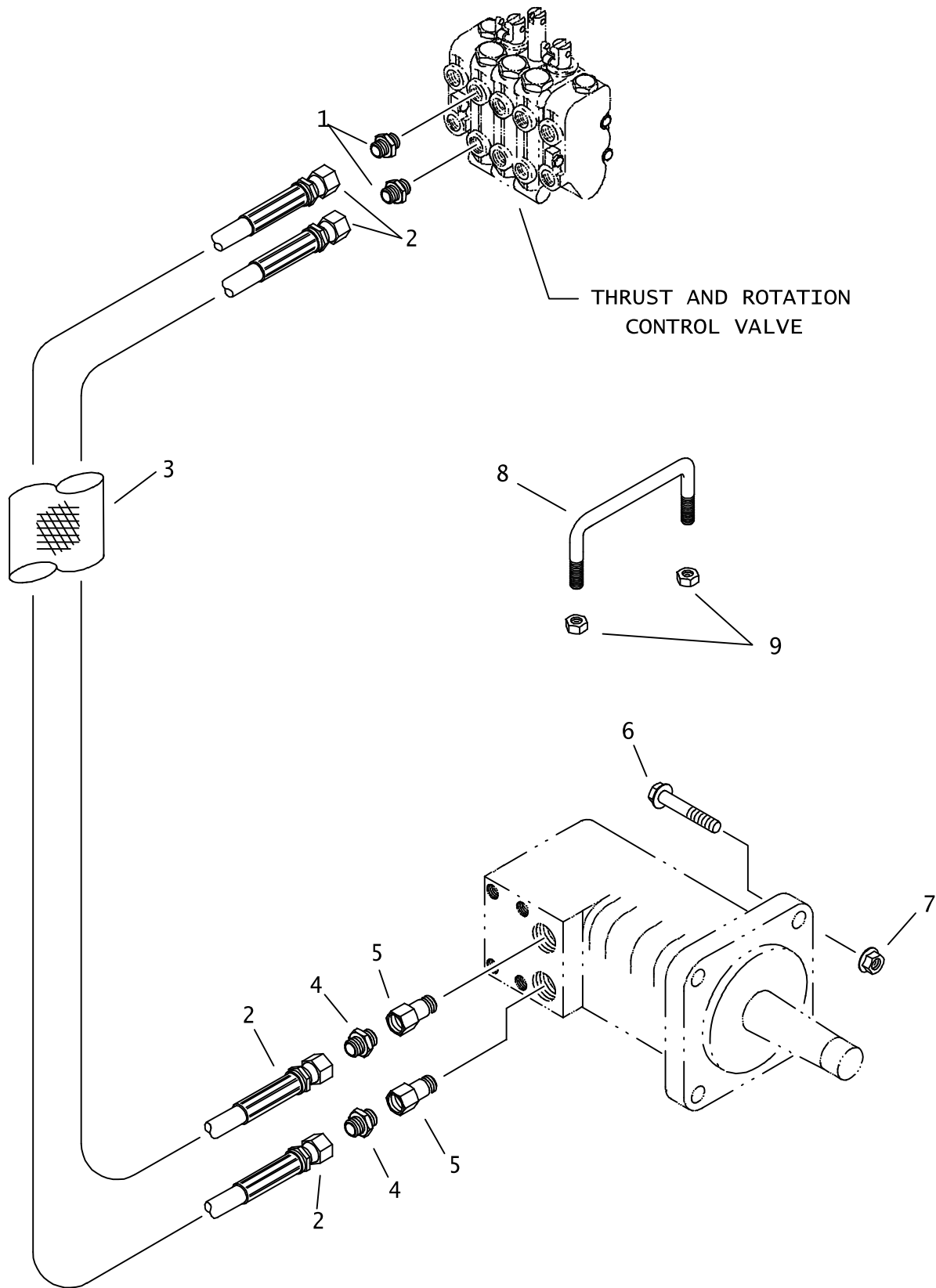

CARRIAGE THRUST HYDRAULICS

REF NO.	PART NUMBER	QTY	DESCRIPTION	REMARKS
1.	154-301	2	CONNECTOR (10S-100)	
2.	515-216	2	HOSE (100FX45-3353MM-207BAR) HOSE (100FX45-132"-3000PSI)	
3.	115-751	1	ABRASION SLEEVE (60MM X 3048MM) ABRASION SLEEVE (2.38" X 120")	
4.	154-308	2	CONNECTOR (100-12S)	
5.	155-222	2	REDUCER (16S-12SF)	
6.	105-462	4	BOLT (5/8-NC X 2-1/4")	
7.	105-357	4	LOCKNUT (5/8-NC)	
8.	355-586	1	HOSE RETAINER	
9.	106-353	4	FLG NUT (M6-1.00)	

NOT SHOWN:

FOOTNOTES:

NOTE:

REFER TO O-RING CHART (800-301) IN BACK OF THE BOOK FOR REPLACEMENT OF SAE AND ORS O-RINGS.

ROTATION HYDRAULICS

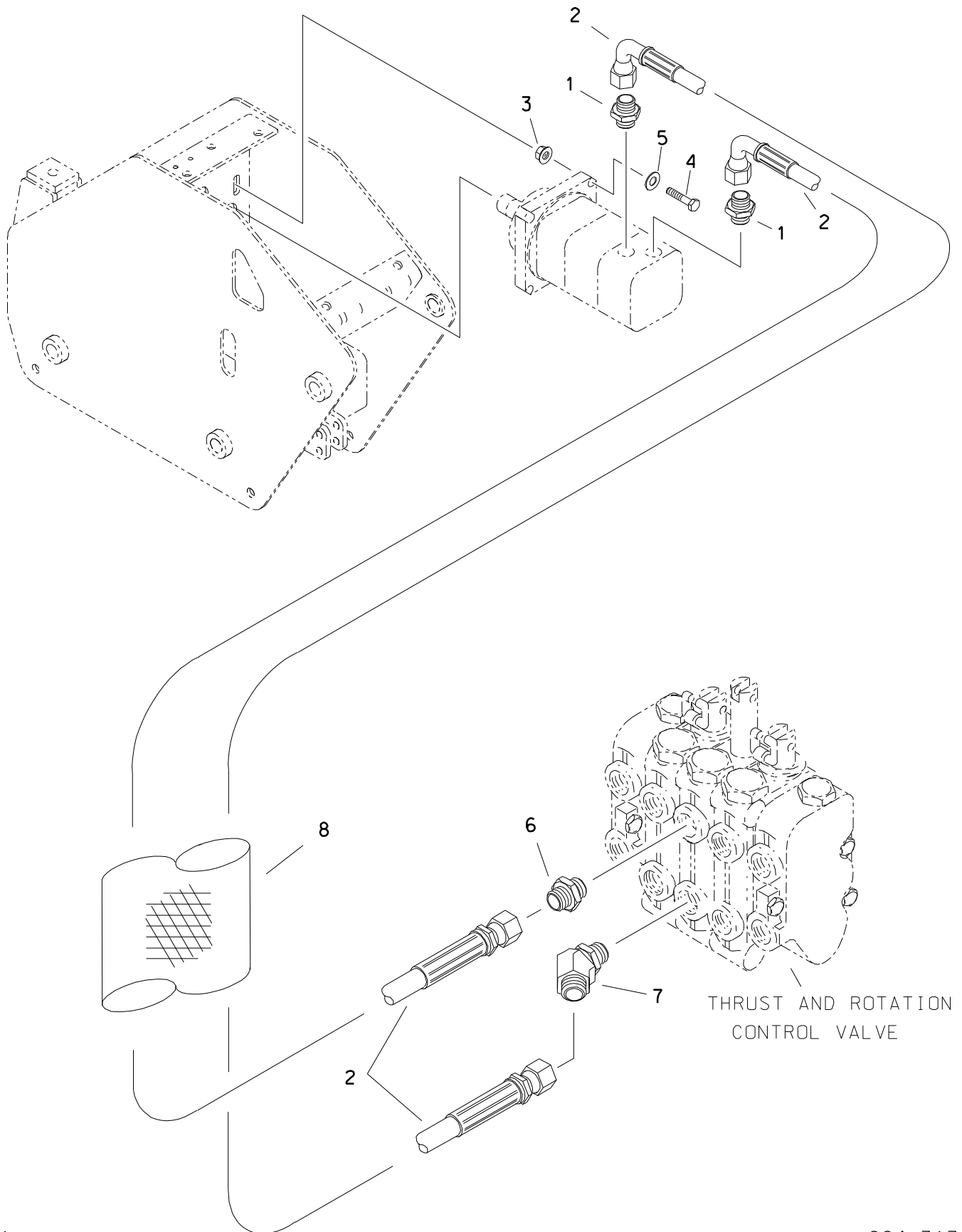

ROTATION HYDRAULICS

REF NO.	PART NUMBER	QTY	DESCRIPTION	REMARKS
1.	154-308	2	CONNECTOR (100-12S)	
2.	515-217	2	HOSE (100FX90-6528MM-207BAR)	
3.	106-354	4	FLG NUT (M12-1.75)	
4.	106-594	4	SCREW (M12-1.75 X 60MM)	
5.	106-391	4	WASHER (M12)	
6.	154-301	1	CONNECTOR (10S-100)	
7.	154-399	1	CONNECTOR (10S-10045)	
8.	115-962	1	ABRASION SLEEVE (65MM X 6477MM)	
			ABRASION SLEEVE (2.54" X 255")	

FOOTNOTES

REFER TO O-RING CHART (800-301) IN BACK OF THE BOOK FOR REPLACEMENT OF SAE AND ORS O-RINGS.

BREAK-OUT HYDRAULICS

ENDS WITH S/N 2M0950

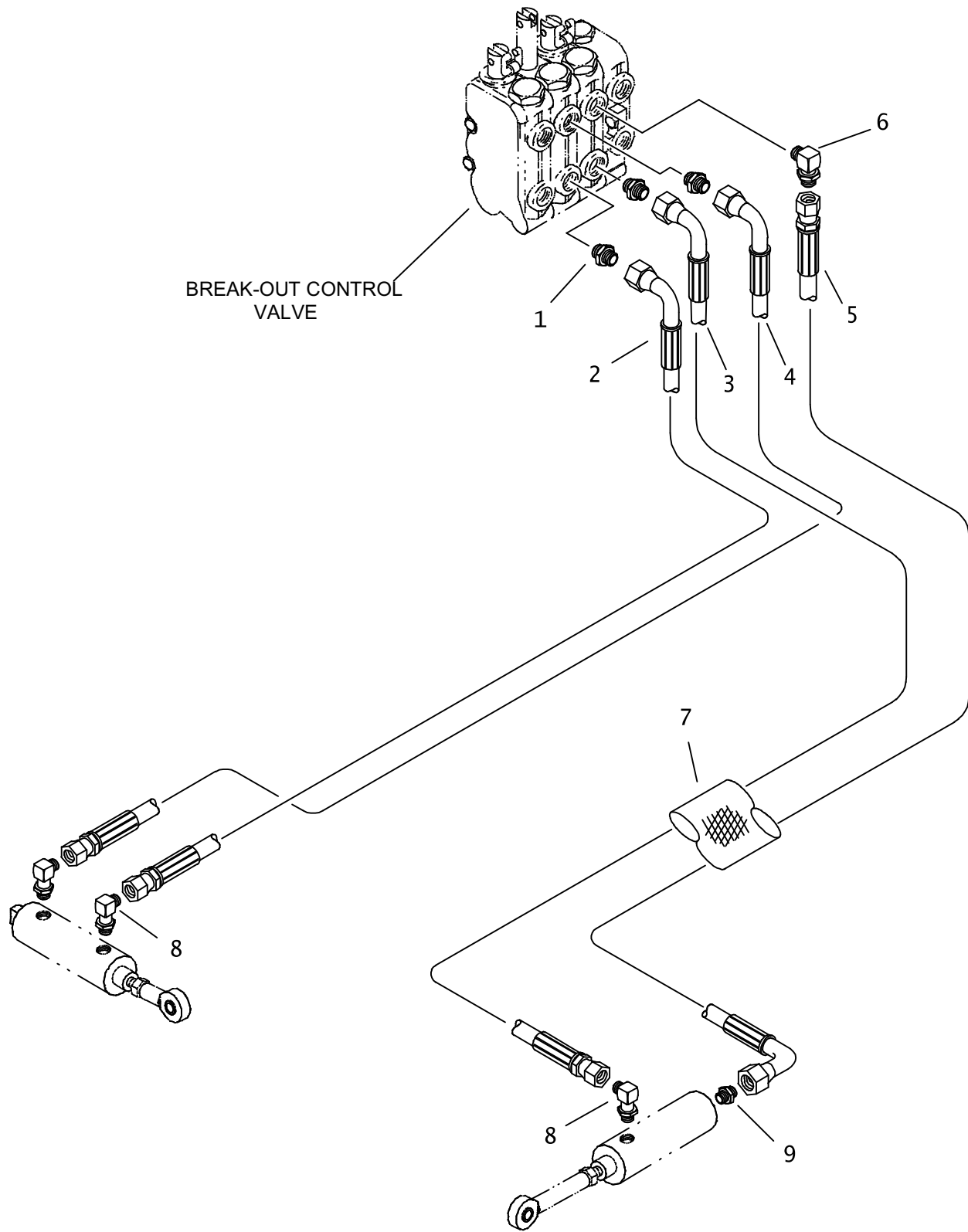

BREAK-OUT HYDRAULICS

ENDS WITH S/N 2M0950

REF NO.	PART NUMBER	QTY	DESCRIPTION	REMARKS
1.	154-261	3	CONNECTOR (040-08S)	
2.	515-184	1	HOSE (040FX90-6045MM-207BAR) HOSE (040FX90-238"-3000PSI)	
3.	515-075	1	HOSE (040FX90-2082MM-207BAR) HOSE (040FX90-82"-3000PSI)	
4.	515-185	1	HOSE (040FX90-6045MM-207BAR) HOSE (040FX-238"-3000PSI)	
5.	515-190	1	HOSE (040FX90-2235MM-207BAR) HOSE (040FX90-88"-3000PSI)	
6.	154-276	1	CONNECTOR (08S-04090)	
7.	115-817	1	ABRASION SLEEVE (4MM X 2134MM) ABRASION SLEEVE (1.59" X 84")	
8.	156-273	3	CONNECTOR (02N-04090)	
9.	154-365	1	CONNECTOR (02N-040)	

NOT SHOWN:

FOOTNOTES:

NOTE:

REFER TO O-RING CHART (800-301) IN BACK OF THE BOOK FOR REPLACEMENT OF SAE AND ORS O-RINGS.

BREAK-OUT HYDRAULICS

BEGINS WITH S/N: 2M0951

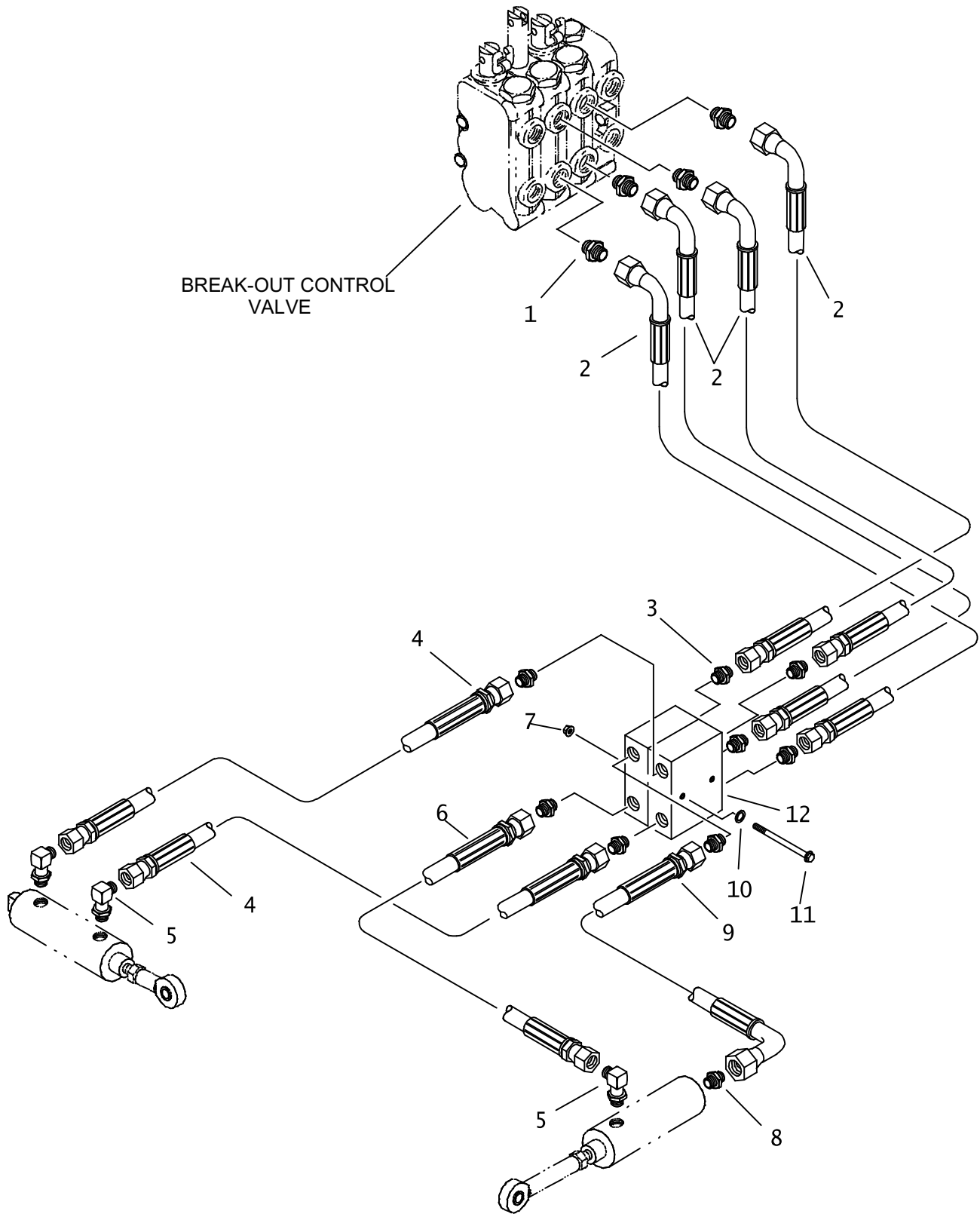

BREAK-OUT HYDRAULICS

BEGINS WITH S/N: 2M0951

REF NO.	PART NUMBER	QTY	DESCRIPTION	REMARKS
1.	154-261	4	CONNECTOR (040-08S)	
2.	154-727	4	HOSE (040FX90-762MM-207BAR) HOSE (040FX90-30"-3000PSI)	
3.	154-220	8	CONNECTOR (040-06S)	
4.	515-285	2	HOSE (040FX-6248MM-207BAR) HOSE (040FX-246"-3000PSI)	
5.	156-273	3	CONNECTOR (02N90-040)	
6.	154-725	1	HOSE (040FX-2286MM-207BAR) HOSE (040FX-90"-3000PSI)	
7.	106-353	2	FLG NUT (M6 X 1.00)	
8.	154-365	1	CONNECTOR (040-02N)	
9.	515-190	1	HOSE (040FX90-2235MM-207BAR) HOSE (040FX90-88"-3000PSI)	
10.	106-076	2	WASHER (1/4")	
11.	106-566	2	SCREW (M6-1 X 70MM)	
12.	155-623	2	CHECK VALVE	

NOT SHOWN:

FOOTNOTES:

NOTE:

REFER TO O-RING CHART (800-301) IN BACK OF THE BOOK FOR REPLACEMENT OF SAE AND ORS O-RINGS.

WATER MOTOR HYDRAULICS

BEGINS W/ SN 2M1670

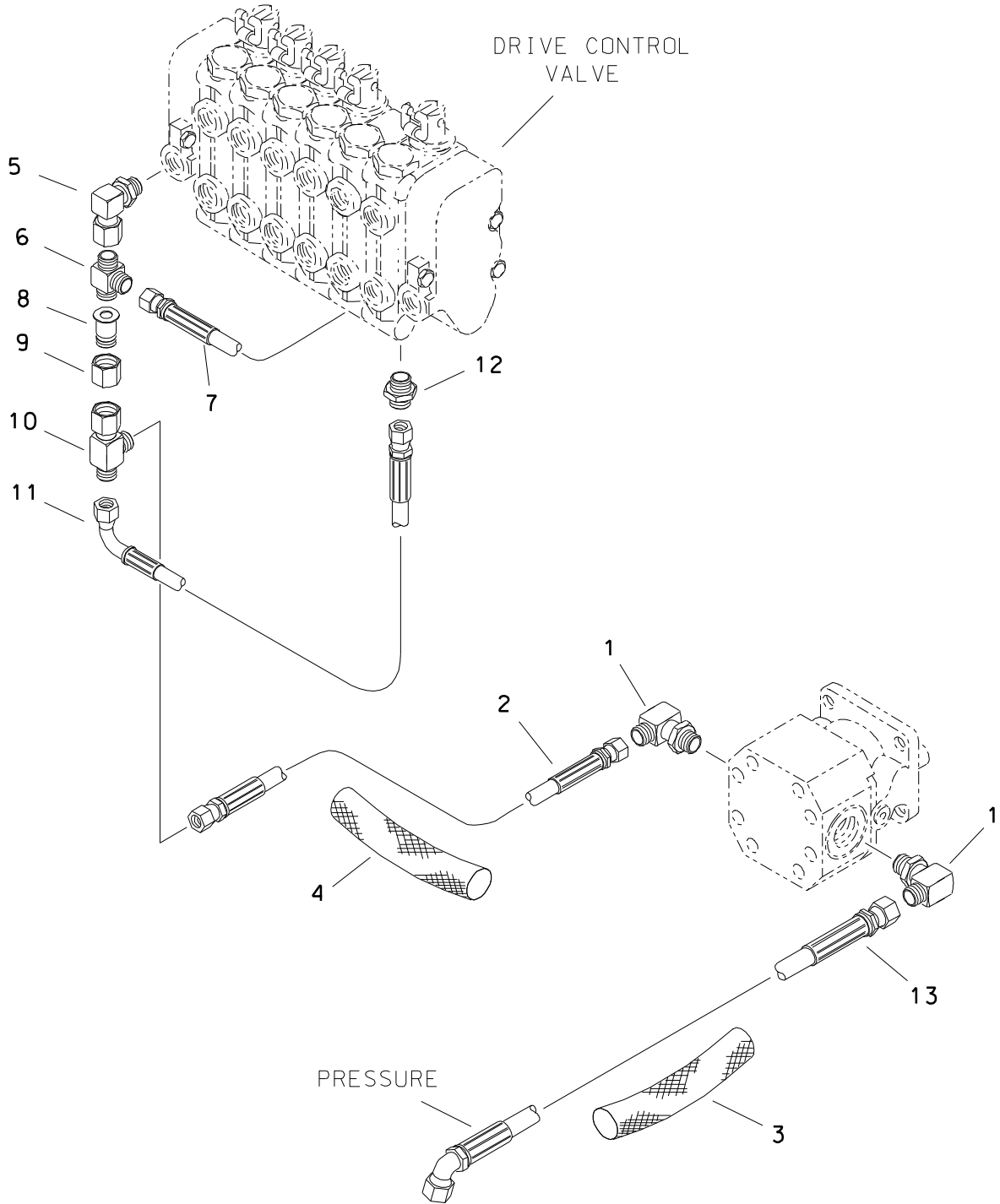

WATER MOTOR HYDRAULICS BEGINS W/ SN 2M1670

REF NO.	PART NUMBER	QTY	DESCRIPTION	REMARKS
1.	154-235	2	CONNECTOR (08S-08090)	
2.	154-745	1	HOSE (080FX-50"-3000PSI)	
3.	115-902	1	ABRASION SLEEVE (1.59" X 100")	
4.	115-903	1	ABRASION SLEEVE (1.59" X 50")	
5.	154-273	1	CONNECTOR (120-10S90)	
6.	154-368	1	UNION RUN TEE (120FX-120-120)	
7.	515-242	1	HOSE (120FX90-95"-3000PSI)	
8.	154-249	1	REDUCER BUSHING STEM (080)	
9.	154-271	1	REDUCER BUSHING NUT (120F)	
10.	154-266	1	UNION RUN TEE (080FX-080-080)	
11.	154-942	1	HOSE (080FX90-13"-3000PSI)	
12.	154-233	1	CONNECTOR (08S-080)	
13.	515-059	1	HOSE (080FX45-94"-3000PSI)	

FOOTNOTES

REFER TO O-RING CHART (800-301) IN BACK OF THE BOOK FOR REPLACEMENT OF SAE AND ORS O-RINGS.

WATER MOTOR HYDRAULICS

ENDS W/ SN 2M1669

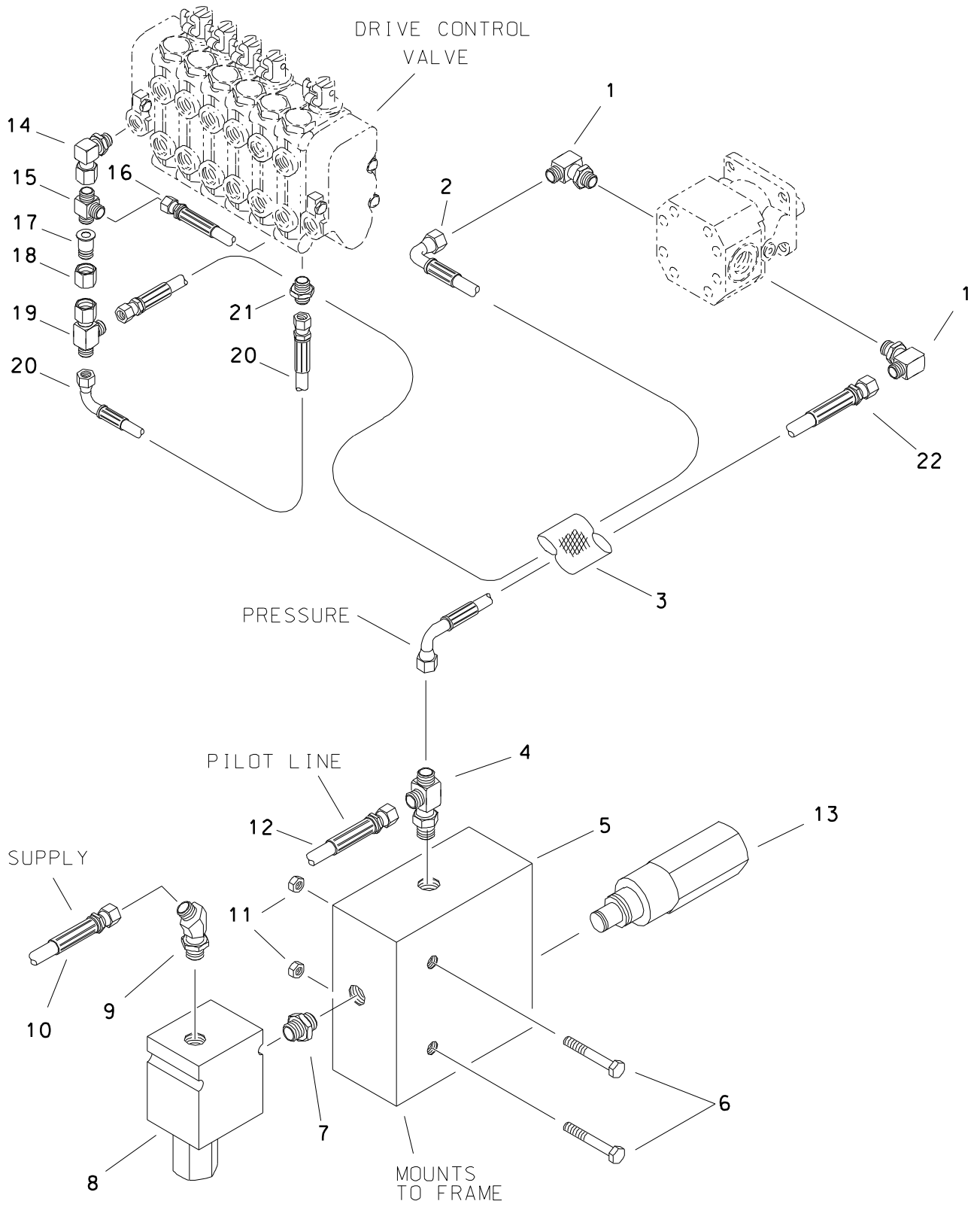

WATER MOTOR HYDRAULICS

ENDS W/ SN 2M1669

REF NO.	PART NUMBER	QTY	DESCRIPTION	REMARKS
1.	154-235	2	CONNECTOR (08S-08090)	
2.	154-902	1	HOSE (080FX90-66"-3000PSI)	
3.	115-755	1	ABRASION SLEEVE (1.59" X 60")	
4.	154-473	1	RUN TEE (10S-080-040)	
5.	158-694	1	HYDRAULIC FLOW VALVE	
	190-098	1	SEAL REPAIR KIT	
6.	105-129	2	BOLT (5/16-NC X 3-1/4")	
7.	156-071	1	UNION (08S-10S)	
8.	158-854	1	FLOW CONTROL VALVE	
9.	154-284	1	CONNECTOR (08S-08045)	
10.	154-678	1	HOSE (080FX-86"-3000PSI)	
11.	105-003	2	FLG LOCKNUT (5/16-NC)	
12.	154-933	1	HOSE (040FX90-94"-5000PSI)	
13.	217-864	1	ELECTRONIC SOLENOID	
14.	154-273	1	CONNECTOR (120-10S90)	
15.	154-368	1	UNION RUN TEE (120FX-120-120)	
16.	515-242	1	HOSE (120FX90-95"-3000PSI)	
17.	154-249	1	REDUCER BUSHING STEM (120)	
18.	154-271	1	REDUCER BUSHING UNIT (120F)	
19.	154-266	1	UNION RUN TEE (080FX-080-080)	
20.	154-942	1	HOSE (080FX90-13"-3000PSI)	
21.	154-233	1	CONNECTOR (08S-080)	
22.	154-750	1	HOSE (080FX90-28"-3000PSI)	

FOOTNOTES

REFER TO O-RING CHART (800-301) IN BACK OF THE BOOK FOR REPLACEMENT OF SAE AND ORS O-RINGS.

MUD MOTOR HYDRAULICS BEGINS W/ SN 2M1670

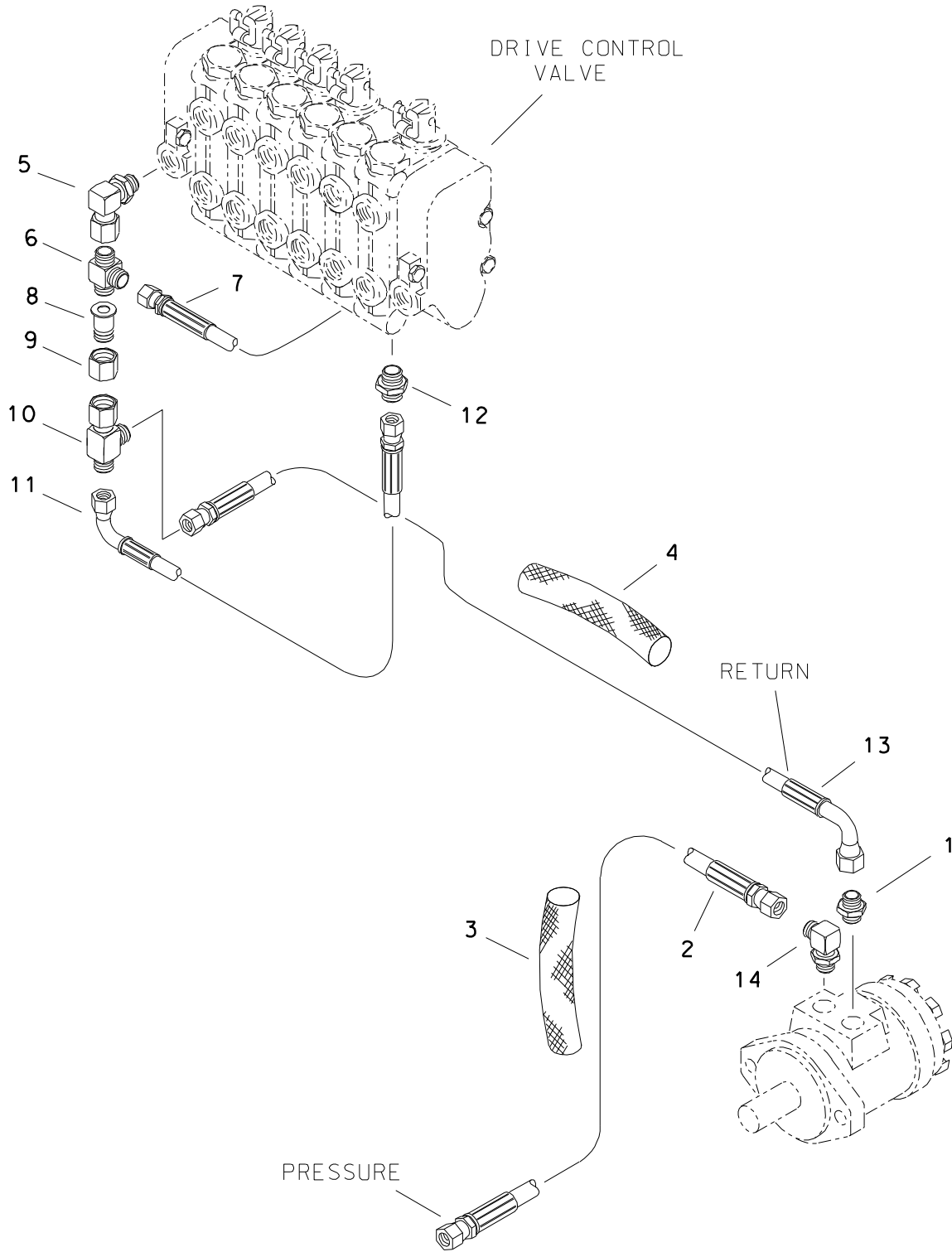

MUD MOTOR HYDRAULICS

BEGINS W/ SN 2M1670

REF NO.	PART NUMBER	QTY	DESCRIPTION	REMARKS
1.	154-279	1	CONNECTOR (080-10S)	
2.	154-662	1	HOSE (080FX90-98"-3000PSI)	
3.	115-902	1	ABRASION SLEEVE (1.59" X 100")	
4.	115-903	1	ABRASION SLEEVE (1.59" X 50")	
5.	154-273	1	CONNECTOR (120-10S90)	
6.	154-368	1	UNION RUN TEE (120FX-120-120)	
7.	515-242	1	HOSE (120FX90-95"-3000PSI)	
8.	154-249	1	REDUCER BUSHING STEM (080)	
9.	154-271	1	REDUCER BUSHING NUT (120F)	
10.	154-266	1	UNION RUN TEE (080FX-080-080)	
11.	154-942	1	HOSE (080FX90-13"-3000PSI)	
12.	154-233	1	CONNECTOR (08S-080)	
13.	154-907	1	HOSE (080FX90-32"-3000PSI)	
14.	154-322	1	CONNECTOR (10S-08090)	

FOOTNOTES

REFER TO O-RING CHART (800-301) IN BACK OF THE BOOK FOR REPLACEMENT OF SAE AND ORS O-RINGS.

MUD MOTOR HYDRAULICS

ENDS W/ SN 2M1669

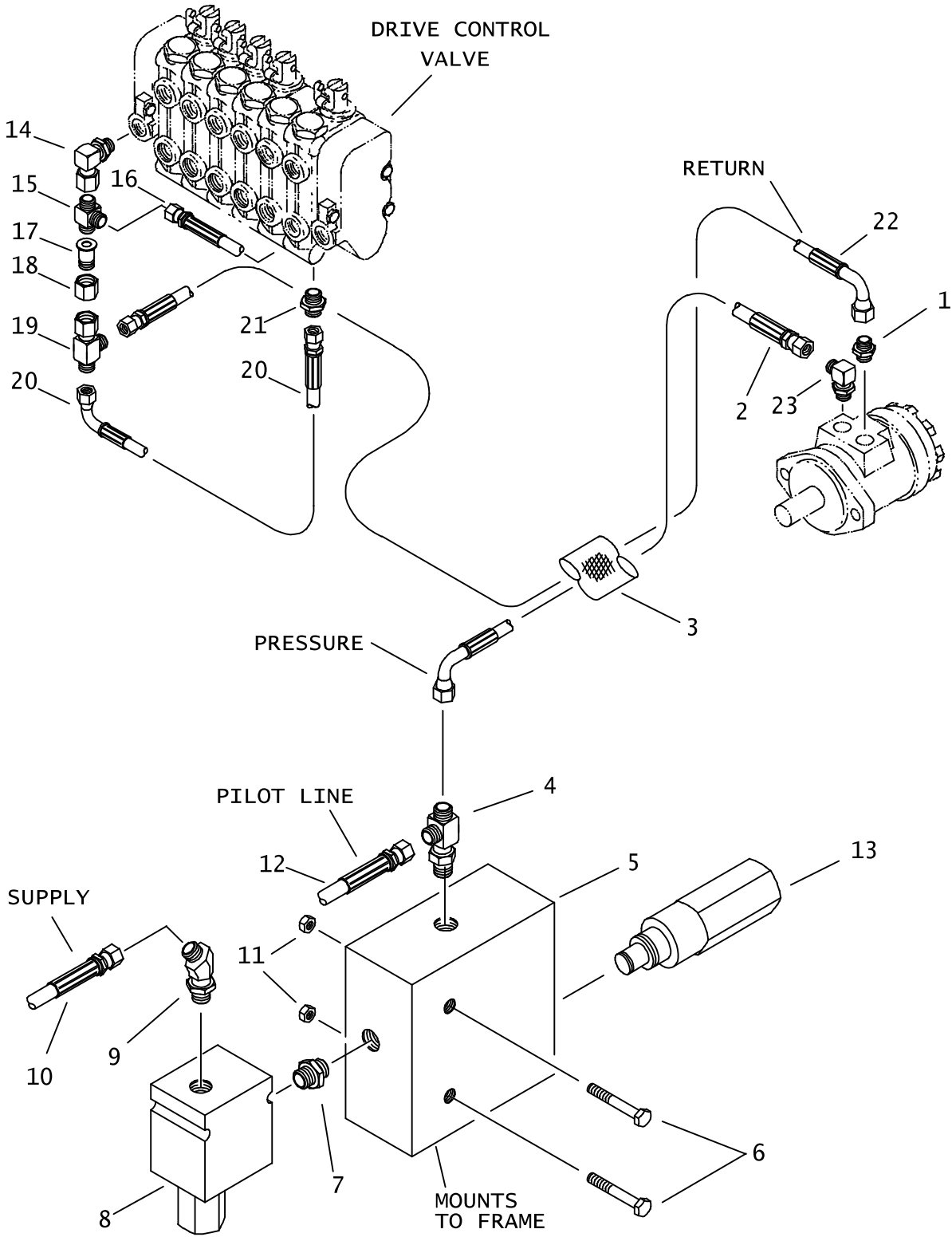

MUD MOTOR HYDRAULICS

ENDS W/ SN 2M1669

REF NO.	PART NUMBER	QTY	DESCRIPTION	REMARKS
1.	154-279	1	CONNECTOR (080-10S)	
2.	154-749	1	HOSE (080FX90-18"-3000PSI)	
3.	117-679	1	ABRASION SLEEVE (1.59" X 32")	
4.	154-473	1	RUN TEE (105-080-040)	
5.	158-694	1	HYDRAULIC FLOW VALVE	
6.	105-129	2	BOLT (5/16-NC X 3-1/4")	
7.	156-071	1	UNION (08S-10S)	
8.	158-854	1	FLOW CONTROL VALVE	
9.	154-284	1	CONNECTOR (08S-08045)	
10.	154-678	1	HOSE (080FX-86"-3000PSI)	
11.	105-003	2	FLG LOCKNUT (5/16-NC)	
12.	154-933	1	HOSE (040FX90-94"-5000PSI)	
13.	217-864	1	ELECTRONIC SOLENOID	
14.	154-273	1	CONNECTOR (120-10S90)	
15.	154-368	1	UNION RUN TEE (120FX-120-120)	
16.	515-242	1	HOSE (120FX90-95"-3000PSI)	
17.	154-249	1	REDUCER BUSHING STEM (120)	
18.	154-271	1	REDUCER BUSHING UNIT (120F)	
19.	154-266	1	UNION RUN TEE (080FX-080-080)	
20.	154-942	1	HOSE (080FX90-13"-3000PSI)	
21.	154-233	1	CONNECTOR (08S-080)	
22.	154-907	1	HOSE (080FX90-32"-3000PSI)	
23.	154-322	1	CONNECTOR (10S-08090)	

NOT SHOWN:

FOOTNOTES:

NOTE:

REFER TO O-RING CHART (800-301) IN BACK OF THE BOOK FOR REPLACEMENT OF SAE AND ORS O-RINGS.

SUPPLY HYDRAULICS

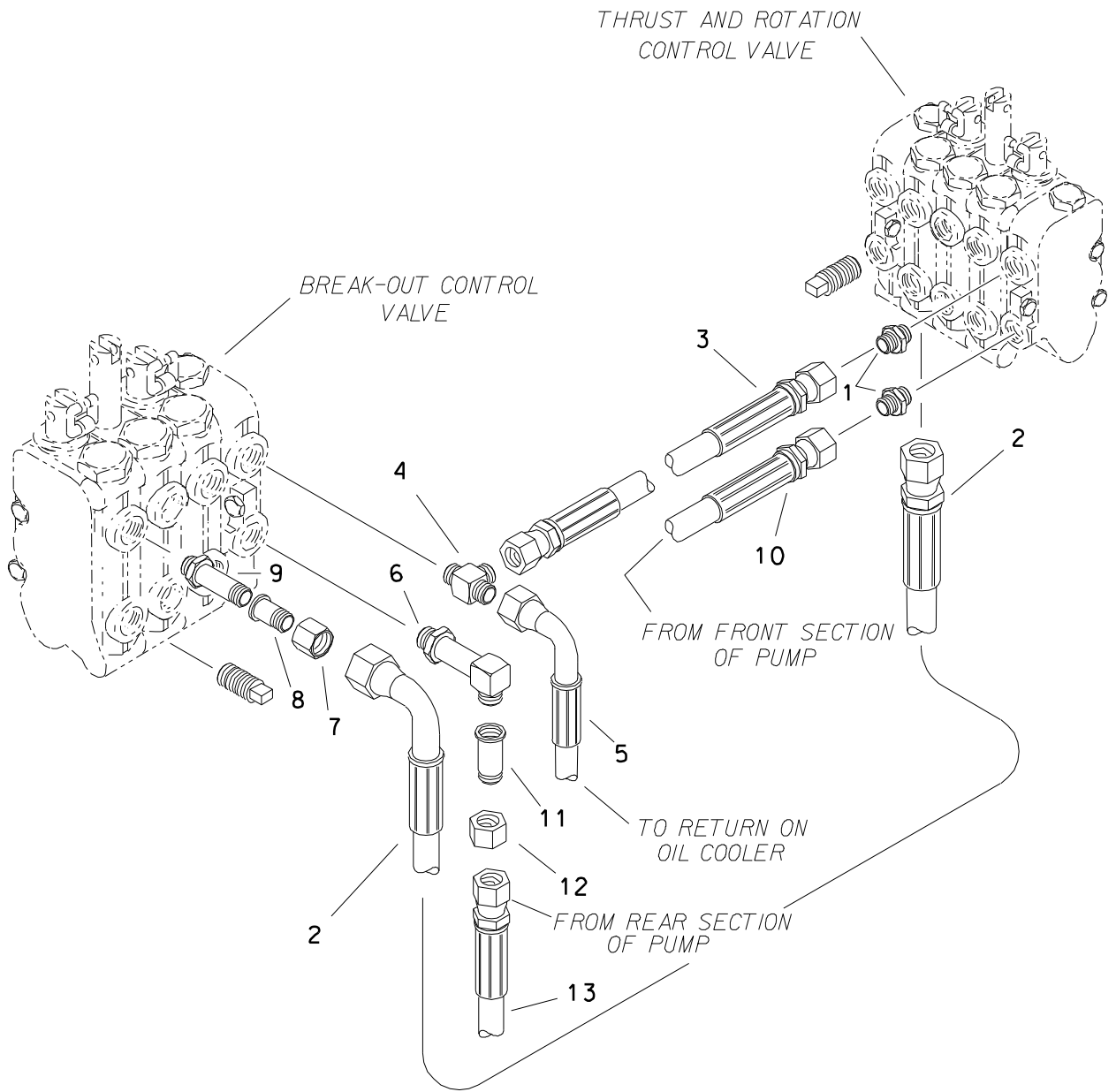

SUPPLY HYDRAULICS

REF NO.	PART NUMBER	QTY	DESCRIPTION	REMARKS
1.	154-269	2	CONNECTOR (12S-120)	
2.	154-854	1	HOSE (08FX90-864MM-207BAR)	
3.	515-213	1	HOSE (08FX90-34"-3000PSI) HOSE (120FX-508MM-207BAR) HOSE (120FX-20"-3000PSI)	
4.	154-292	1	RUN TEE (12S-120-120)	
5.	515-218	1	HOSE (120FX90-2032MM-207BAR) HOSE (120FX90-80"-3000PSI)	
6.	154-338	1	CONNECTOR (12S-12090)	
7.	154-310	1	REDUCER BUSHING NUT (100)	
8.	154-312	1	REDUCER BUSHING STEM (080)	
9.	514-105	1	CONNECTOR (10-100)	
10.	154-946	1	HOSE (120FX-2490MM-207BAR) HOSE (120FX-98"-3000PSI)	
11.	154-249	1	REDUCER BUSHING STEM (080)	
12.	154-271	1	REDUCER BUSHING NUT (120F)	
13.	154-971	1	HOSE (080FX90-1981MM-207BAR) HOSE (080FX90-78"-3000PSI)	

FOOTNOTES

REFER TO O-RING CHART (800-301) IN BACK OF THE BOOK FOR REPLACEMENT OF ORS AND SAE O-RINGS,

FLOW DIVIDER

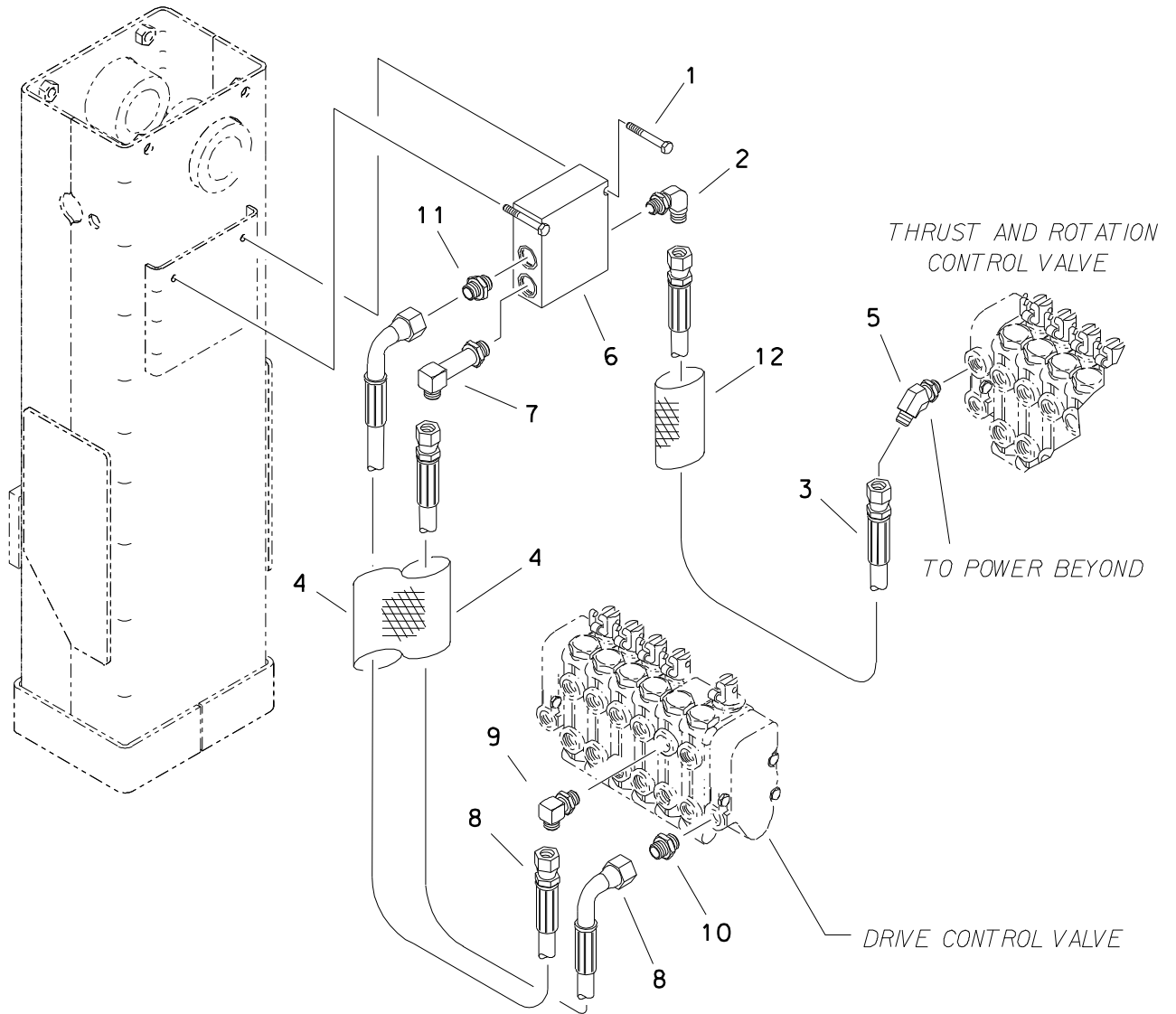

FLOW DIVIDER

REF NO.	PART NUMBER	QTY	DESCRIPTION	REMARKS
1.	106-330	2	FLG SCREW (M8-1.25 X 70MM)	
2.	154-270	1	CONNECTOR (12S-12090)	
3.	515-219	1	HOSE (120FX45-3658MM-207 BAR) HOSE (120FX45-144"-3000 PSI)	
4.	116-634	2	ABRASION SLEEVE (40MM X 3302MM) ABRASION SLEEVE (1.59" X 130")	WITH WATER TANK
	115-713	2	ABRASION SLEEVE (40MM X 610MM) ABRASION SLEEVE (1.59" X 24")	WITH WATER TANK
5.	154-251	1	CONNECTOR (12Q-12S45)	
6.	158-815	1	FLOW DIVIDER	
	500-990	1	CARTRIDGE	
	190-721	1	SEAL KIT	
7.	154-338	1	CONNECTOR (12S-12090)	
8.	515-083	2	HOSE (120FX90-1676MM-207 BAR) HOSE (120FX90-66"-3000 PSI)	WITH WATER TANK
	154-687	2	HOSE (12-711MM-207 BAR) HOSE (12-28"-3000 PSI)	WITHOUT WATER TANK
9.	154-273	1	CONNECTOR (12Q-10S90)	
10.	154-247	1	CONNECTOR (10S-120)	
11.	154-269	1	CONNECTOR (12S-120)	WITH WATER TANK
	154-388	1	CONNECTOR (12S-12090)	WITHOUT WATER TANK
12.	116-632	1	ABRASION SLEEVE (40MM X 1651MM) ABRASION SLEEVE (1.59" X 65")	

FOOTNOTES

REFER TO O-RING CHART (800-301) IN BACK OF BOOK FOR REPLACEMENT OF SAE AND ORS O-RINGS.

PUMP HYDRAULICS BEGINS W/ SN 2M1670

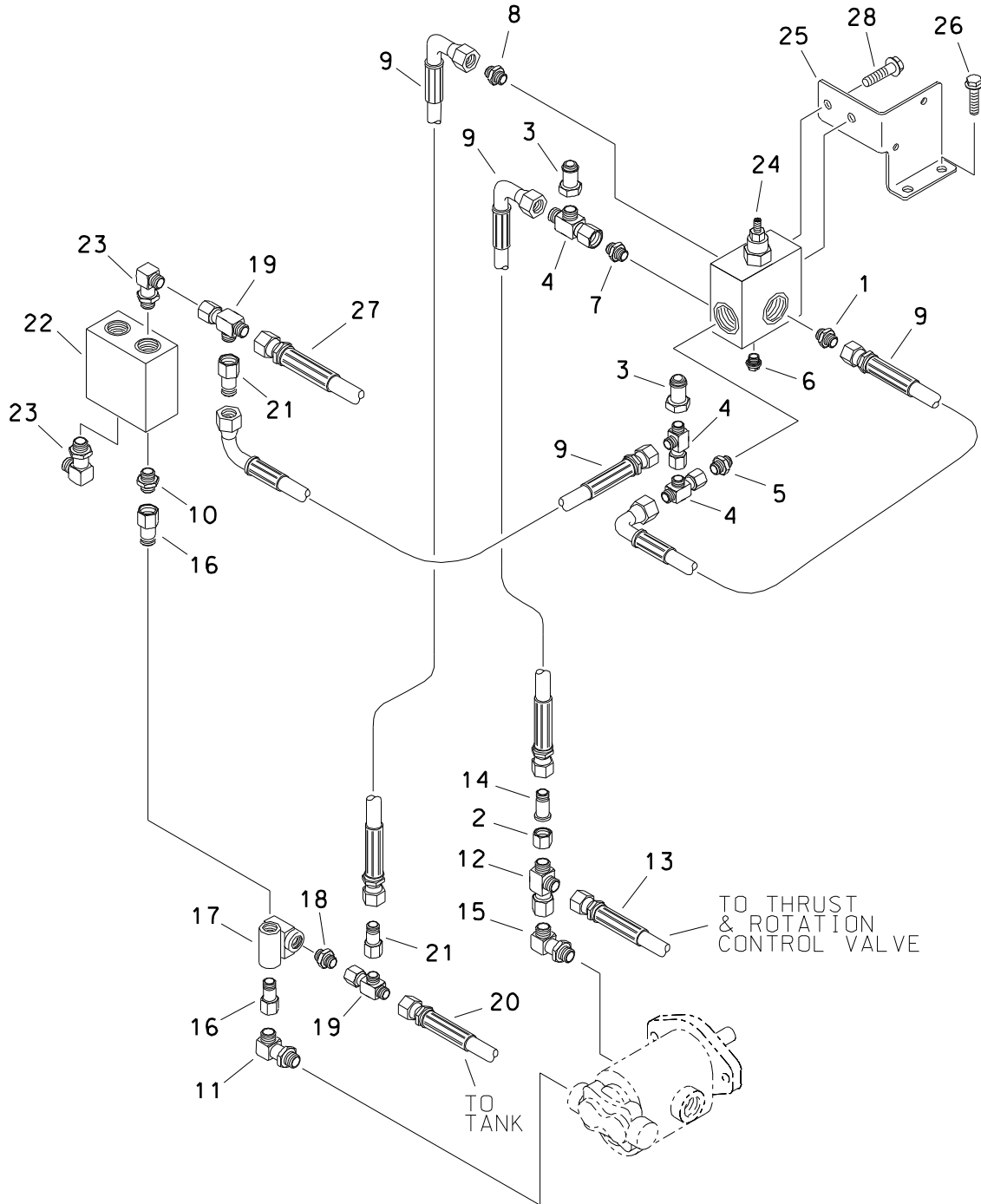

**PUMP HYDRAULICS
BEGINS W/ SN 2M1670**

REF NO.	PART NUMBER	QTY	DESCRIPTION	REMARKS
1.	156-066	1	CONNECTOR (06S-060, ORF .019")	
2.	154-271	1	REDUCER BUSHING NUT (120F)	
3.	159-157	2	QDC ADAPTER (02-060F)	
4.	154-344	3	UNION RUN TEE (060FX-060-060)	
5.	154-221	1	CONNECTOR (06S-060)	
6.	115-153	1	PLUG (04N, SQ)	
7.	156-067	1	CONNECTOR (06S-060, ORF .031")	
8.	156-065	1	CONNECTOR (06S-060, ORF .101")	
9.	154-737	4	HOSE (060FX90-17"-3000PSI)	
10.	514-231	1	CONNECTOR (06S-100)	
11.	154-300	1	CONNECTOR (100-12S90)	
12.	154-368	1	UNION RUN TEE (120FX-120-120)	
13.	154-946	1	HOSE (120FX-98"-3000PSI)	
14.	154-459	1	REDUCER STEM (060)	
15.	154-338	1	CONNECTOR (12S-12090)	
16.	514-079	2	UNION (10S-100FX)	
17.	158-601	1	HYDRAULIC RELIEF VALVE	
18.	154-279	1	CONNECTOR (080-10S)	
19.	154-266	2	UNION RUN TEE (080FX-080-080)	
20.	154-942	1	HOSE (080FX90-13"-3000PSI)	
21.	154-262	2	REDUCER (060-080F)	
22.	158-871	1	HYDRAULIC FLOW VALVE	
23.	154-253	2	CONNECTOR (06S-08090)	
24.	158-814	1	CONTROL VALVE	
25.	353-799	1	VALVE MOUNT	
26.	106-380	2	FLG LK SCREW (M8-1.25 X 16MM)	
27.	154-933	1	HOSE (040FX90 - 94"-5000PSI)	
28.	501-153	2	FLG LK BOLT (3/8-NC X 5/8")	

FOOTNOTES

REFER TO O-RING CHART (800-301) IN BACK OF THE BOOK FOR REPLACEMENT OF SAE AND ORS O-RINGS.

PUMP HYDRAULICS

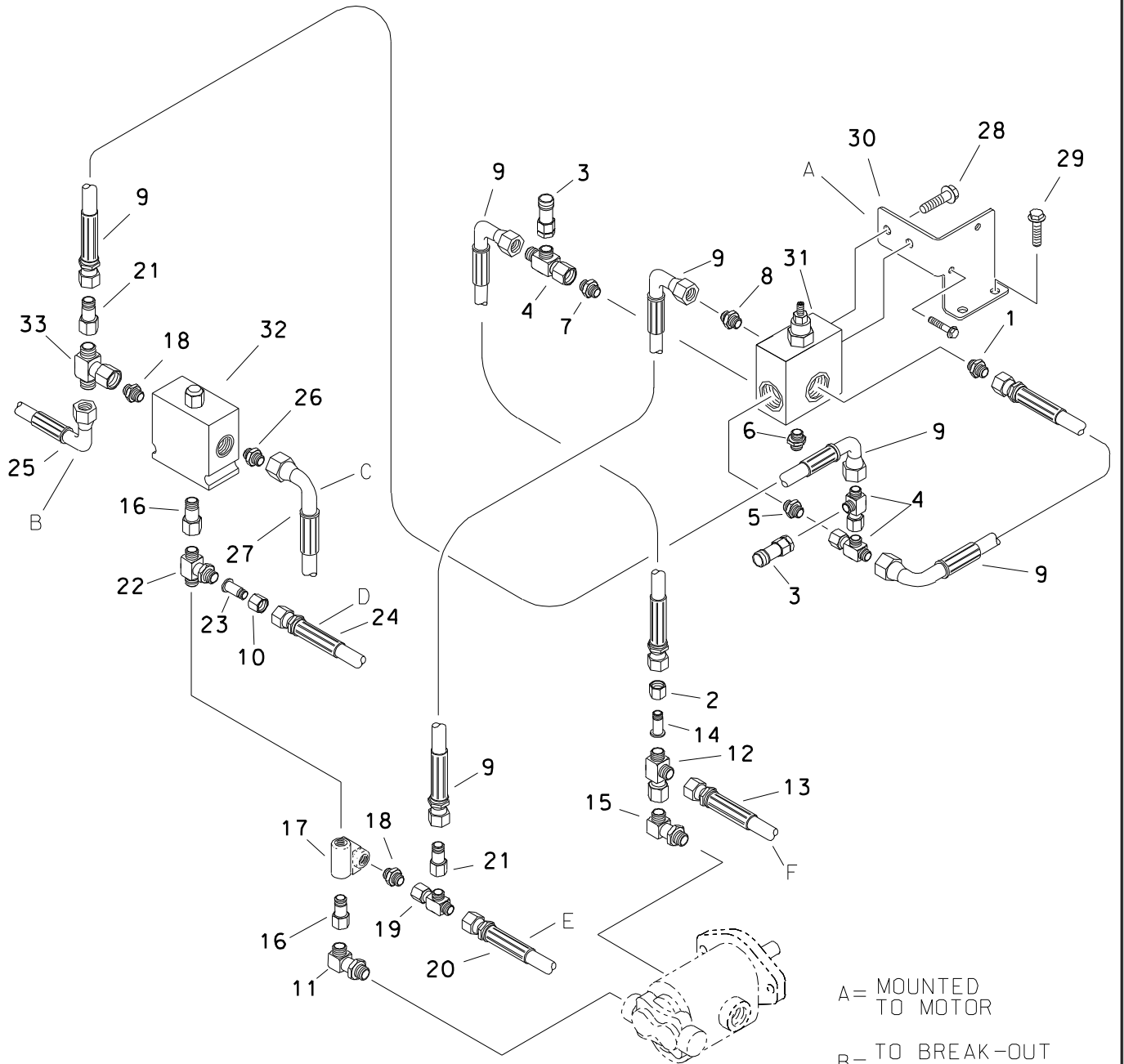

- A= MOUNTED TO MOTOR
- B= TO BREAK-OUT CONTROL VALVE
- C= FROM HYDRAULIC FLOW VALVE
- D= TO FLOW CONTROL VALVE
- E= TO TANK
- F= TO THRUST AND ROTATION CONTROL VALVE

PUMP HYDRAULICS

REF NO.	PART NUMBER	QTY	DESCRIPTION	REMARKS
1.	156-066	1	CONNECTOR (06S-060, ORF .019")	
2.	154-271	1	REDUCER BUSHING NUT (120F)	
3.	159-157	2	QDC ADAPTER (02-060F)	
4.	154-344	3	UNION RUN TEE (060FX-060-060)	
5.	154-221	1	CONNECTOR (06S-060)	
6.	115-153	1	PLUG (04N, SQ)	
7.	156-067	1	CONNECTOR (06S-060, ORF .031")	
8.	156-065	1	CONNECTOR (06S-060, ORF .101")	
9.	154-737	4	HOSE (060FX90-432MM-207BAR) HOSE (060FX90-17"-3000PSI)	
10.	154-310	1	REDUCER BUSHING NUT (100)	
11.	154-300	1	CONNECTOR (100-120FX90)	
12.	154-368	1	UNION RUN TEE (120FX-120-120)	
13.	154-946	1	HOSE (120FX-2489MM-207BAR) HOSE (120FX-98"-3000PSI)	
14.	154-459	1	REDUCER STEM (060)	
15.	154-338	1	CONNECTOR (120FX-12090)	
16.	514-079	2	UNION (10S-100FX)	
17.	158-601	1	HYDRAULIC RELIEF VALVE	
18.	154-279	1	CONNECTOR (080-10S)	
19.	154-266	1	UNION RUN TEE (080FX-080-080)	
20.	154-942	1	HOSE (080FX90-330MM-207BAR) HOSE (080FX90-13"-3000PSI)	
21.	154-262	2	REDUCER (060-080F)	
22.	154-317	1	RUN TEE (10S-100-100)	
23.	154-312	1	REDUCER BUSHING STEM (080)	
24.	154-678	1	HOSE (080FX-2184MM-207BAR) HOSE (080FX-86"-3000PSI)	
25.	154-971	1	HOSE (080FX90-1981MM-207BAR) HOSE (080FX90-78"-3000PSI)	
26.	156-069	1	CONNECTOR (04FX-040)	
27.	154-933	1	HOSE (040FX90 -2388MM-345BAR) HOSE (040FX90 - 94"-5000PSI)	
28.	501-153	2	FLG LK BOLT (3/8-NC X 5/8")	
29.	106-380	2	FLG LK SCREW (M8-1.25 X 16MM)	
30.	353-799	1	VALVE MOUNT	
31.	158-814	1	CONTROL VALVE	
	190-643		SEAL REPAIR KIT	
32.	158-687	1	PRIORITY VALVE	
33.	154-257	1	SWIVEL BRANCH TEE (080)	

FOOTNOTES

REFER TO O-RING CHART (800-301) IN BACK OF THE BOOK FOR REPLACEMENT OF SAE AND ORS O-RINGS.

PUMP HYDRAULICS WITHOUT WATER TANK

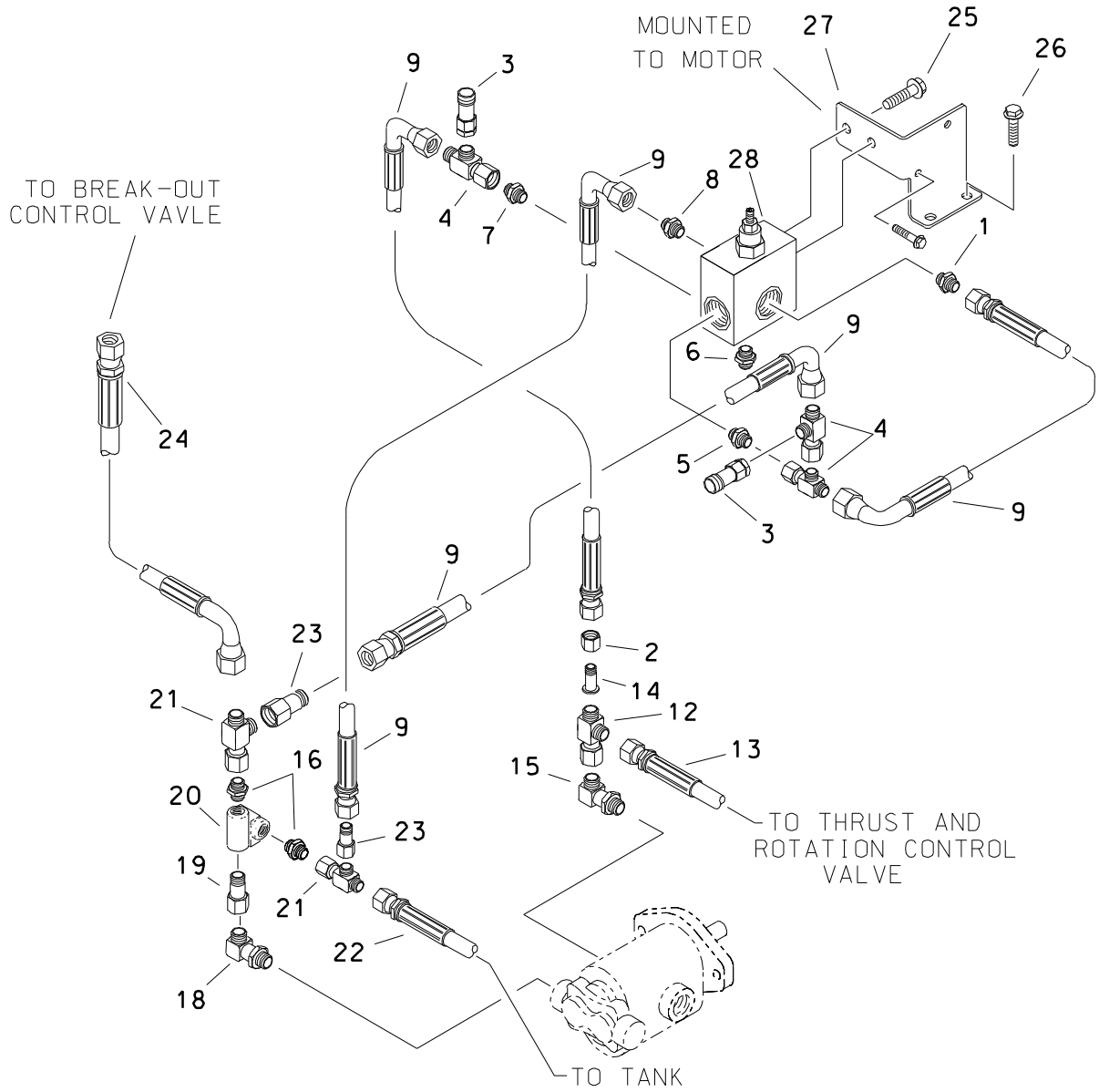

PUMP HYDRAULICS WITHOUT WATER TANK

REF NO.	PART NUMBER	QTY	DESCRIPTION	REMARKS
1.	156-066	1	CONNECTOR (06S-060, ORF .019")	
2.	154-271	1	REDUCER BUSHING NUT (120F)	
3.	159-157	2	QDC ADAPTER (02-060F)	
4.	154-344	3	UNION RUN TEE (060FX-060-060)	
5.	154-221	1	CONNECTOR (06S-060)	
6.	115-153	1	PLUG (04N, SQ)	
7.	156-067	1	CONNECTOR (06S-060, ORF .031")	
8.	156-065	1	CONNECTOR (06S-060, ORF .101")	
9.	154-737	4	HOSE (060FX90-432MM-207BAR) HOSE (060FX90-17"-3000PSI)	
10.	154-310	1	REDUCER BUSHING NUT (100)	
11.	514-134	1	REDUCER (100-060)	
12.	154-368	1	UNION RUN TEE (100FX-100-100)	
13.	154-946	1	HOSE (120FX-2489MM-207BAR) HOSE (120FX-98"-3000PSI)	
14.	154-459	1	REDUCER STEM (060)	
15.	154-338	1	CONNECTOR (12S-12090)	
16.	154-279	2	CONNECTOR (080-10S)	
17.	154-308	1	CONNECTOR (100-12S)	
18.	154-300	1	CONNECTOR (100FX-12090)	
19.	514-079	1	UNION (10S-100FX)	
20.	158-601	1	HYDRAULIC RELIEF VALVE	
21.	154-266	2	UNION RUN TEE (080FX-080-080)	
22.	154-942	1	HOSE (080FX90-330MM-207BAR) HOSE (080FX90-13"-3000PSI)	
23.	154-262	2	REDUCER (060-080F)	
24.	154-971	1	HOSE (080-08090S-1981MM-207BAR) HOSE (080-08090S-78"-3000PSI)	
25.	501-153	2	FLG LK BOLT (3/8-NC X 5/8")	
26.	106-380	2	FLG LK SCREW (M8-1.25 X 16MM)	
27.	353-799	1	VALVE MOUNT	
28.	158-814	1	CONTROL VALVE	
	190-643		SEAL KIT	

FOOTNOTES

REFER TO O-RING CHART (800-301) IN BACK OF THE BOOK FOR REPLACEMENT OF SAE AND ORS O-RINGS.

WATER TANK PLUMBING

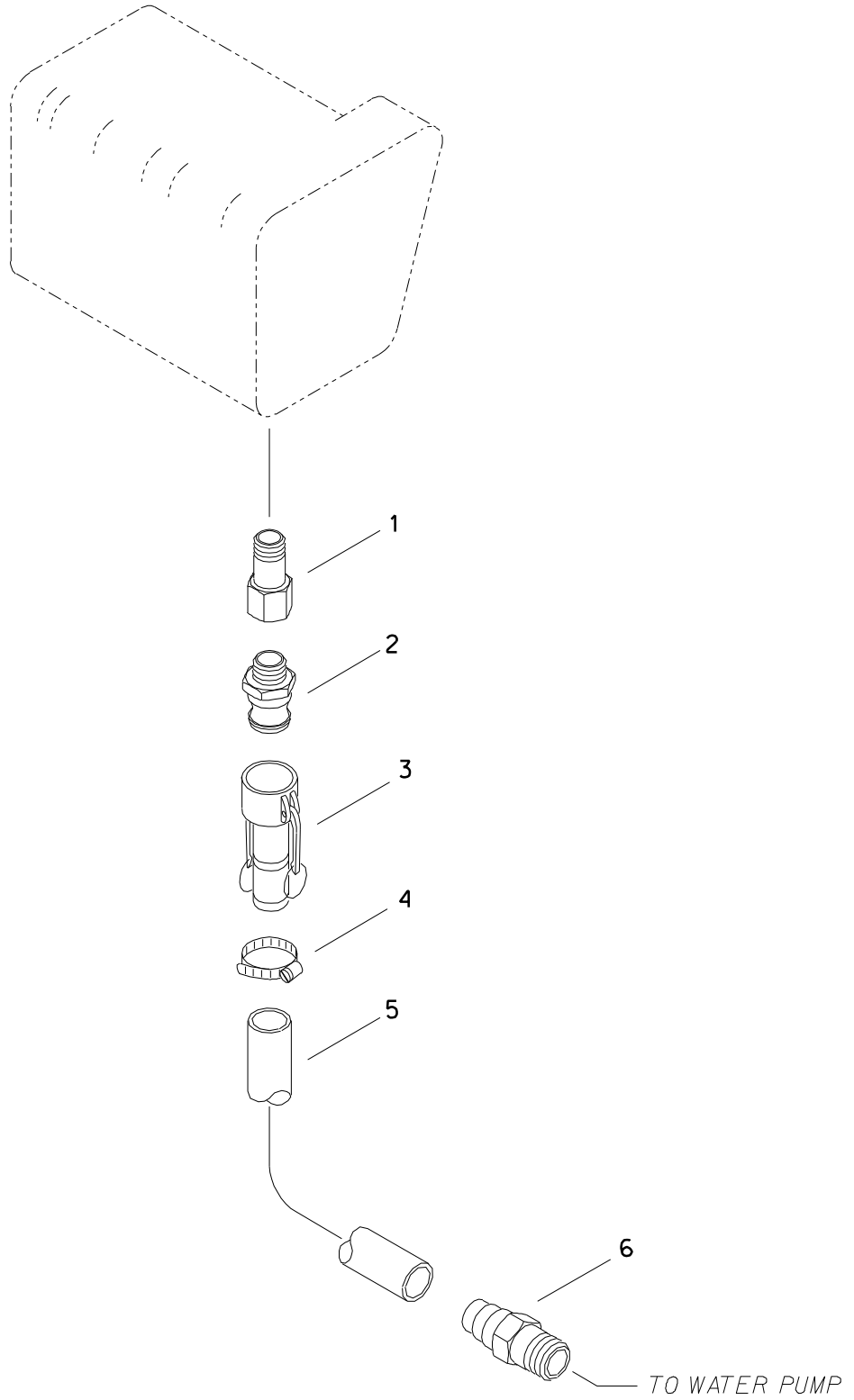

WATER TANK PLUMBING

REF NO.	PART NUMBER	QTY	DESCRIPTION	REMARKS
1.	115-276	1	REDUCER (16N-08NF)	
2.	159-306	1	FHC ADAPTER (08-08N)	
3.	159-307	1	FHC BODY (08-08H)	
4.	110-026	2	WORM CLAMP (13MM TO 32MM) WORM CLAMP (1/2" TO 1-1/4")	
5.	116-286	AR	BULK HOSE (13MM ID-23BAR) BULK HOSE (1/2" ID-325PSI)	SOLD PER 25MM-USE 915MM SOLD PER 1"-USE 36"
6.	514-025	1	SLIP-ON COUPLER (08N-08H)	

FOOTNOTES

REFER TO O-RING CHART (800-301) IN BACK OF THE BOOK FOR REPLACEMENT OF SAE AND ORS O-RINGS.

MUD TANK PLUMBING

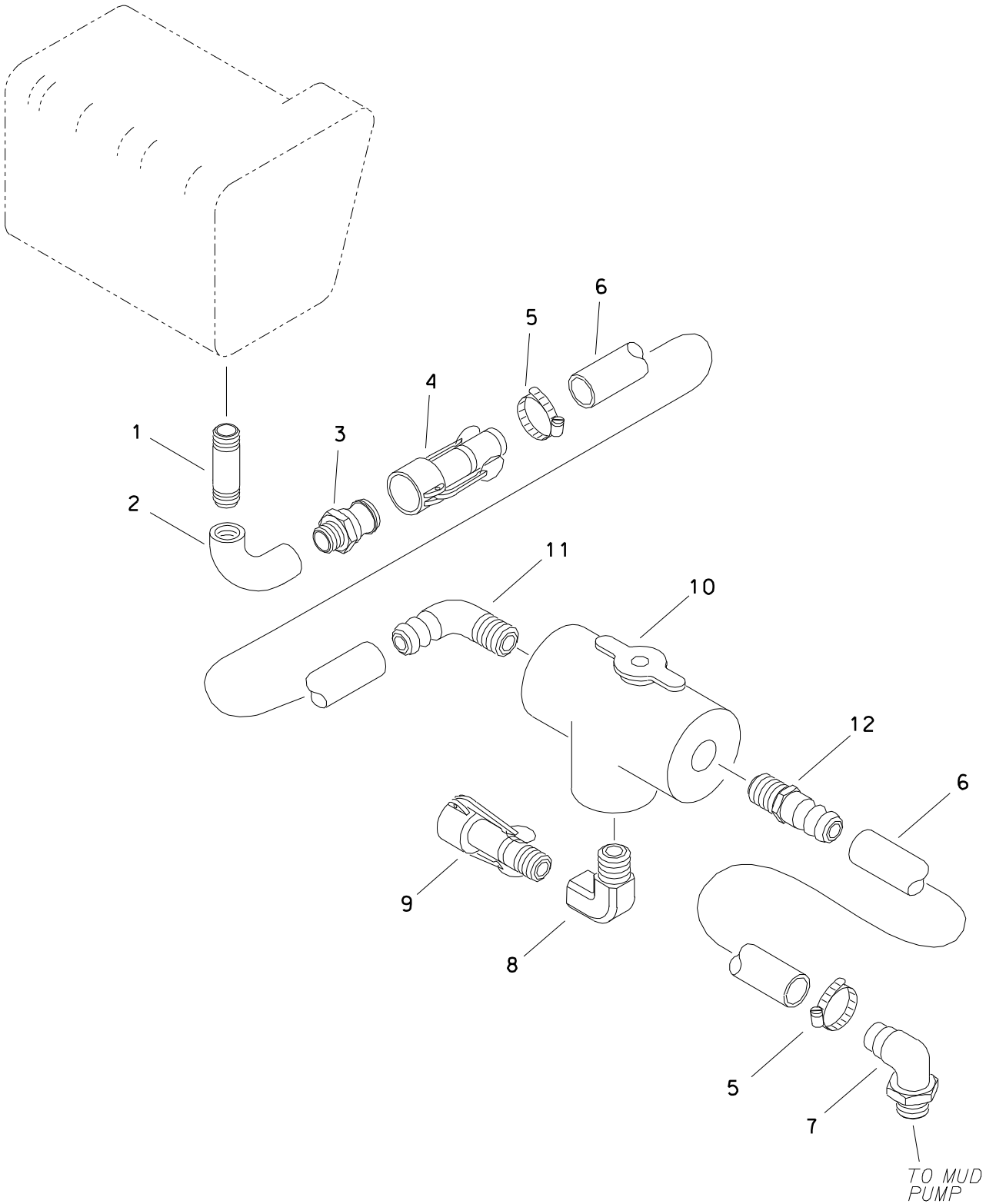

MUD TANK PLUMBING

REF NO.	PART NUMBER	QTY	DESCRIPTION	REMARKS
1.	115-206	1	NIPPLE (16N-2-1/2")	
2.	115-208	1	ELBOW (16NF-16NF90)	
3.	155-232	1	FHC ADAPTER (16-16N)	
4.	155-233	1	FHC BODY (16-16H)	
5.	110-353	2	WORM CLAMP (3/4" TO 1-1/5")	
6.	116-460	AR	BULK HOSE (1" ID-200PSI)	SOLD PER 1"-USE 2 @ 48"
7.	156-075	1	S/O CPLR (16N-16H90, 08NF)	
8.	514-214	1	STREET ELBOW (16N-16NF90)	
9.	156-083	1	FHC BODY (16-16N)	
10.	158-875	1	3-WAY VALVE (16NF)	
11.	514-215	1	S/O CPLR (16N-16H90)	
12.	514-208	1	S/O CPLR (16N-16H)	

FOOTNOTES

REFER TO O-RING CHART (800-301) IN BACK OF THE BOOK FOR REPLACEMENT OF SAE AND ORS O-RINGS.

WATER PUMP PLUMBING

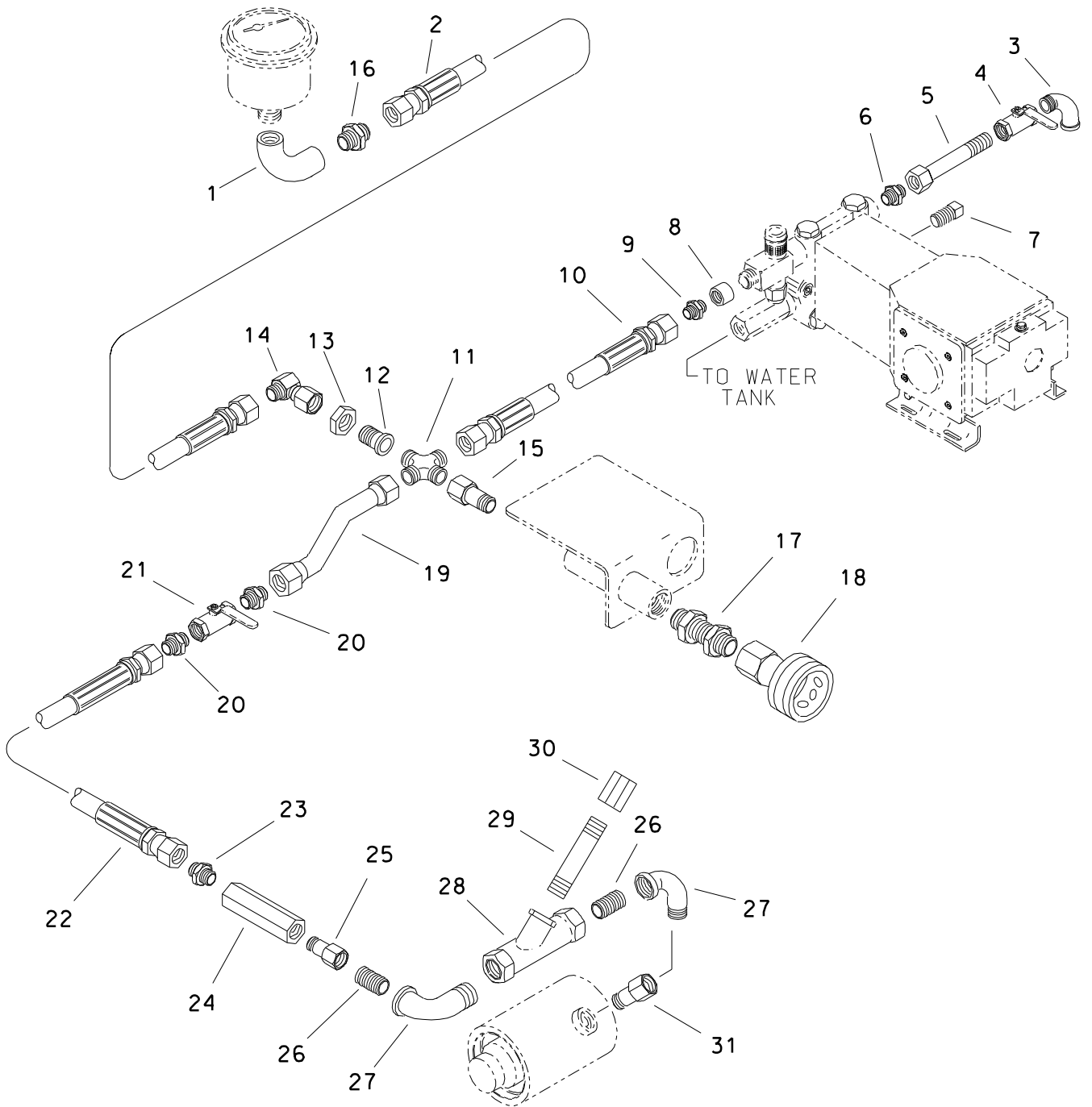

WATER PUMP PLUMBING

REF NO.	PART NUMBER	QTY	DESCRIPTION	REMARKS
1.	114-016	1	ELBOW (1/4" NPT)	
2.	154-811	1	HOSE (040FX-2946MM-207BAR)	
			HOSE (040FX-116"-3000PSI)	
3.	155-120	1	STREET ELBOW (04N-04NF90)	
4.	120-071	1	BALL VALVE (04NF-04NF)	
5.	115-136	1	NIPPLE (04N-4")	
6.	115-106	1	REDUCER (06N-04NF)	
7.	115-112	1	PLUG (08N, SQ)	
8.	115-182	1	COLLAR (06NF)	
9.	514-141	1	CONNECTOR (06N-080)	
10.	154-828	1	HOSE (080FX-432MM-207BAR)	
			HOSE (080FX-17"-3000PSI)	
11.	514-145	1	CROSS (080F)	
12.	154-248	1	REDUCER STEM (040)	
13.	154-272	1	REDUCER NUT (080NF)	
14.	154-255	1	UNION (040-040FX90)	
15.	156-732	1	CONNECTOR (08J-080F)	
16.	154-339	1	CONNECTOR (04N-040)	
17.	154-466	1	CONNECTOR (08S-08S)	
18.	159-088	1	QDC BODY (08-08SF)	
	190-186	1	SEAL REPAIR KIT	
19.	156-590	1	HYDRAULIC TUBE	
20.	154-349	2	CONNECTOR (08N-080)	
21.	158-579	1	SHUT-OFF (08NF-08NF)	
22.	515-215	1	HOSE (080FX-5004MM-207BAR)	
			HOSE (080FX-197"-3000PSI)	
23.	154-354	1	CONNECTOR (12N-080)	
24.	159-160	1	FLOW CHECK (12NF-12NF)	
25.	155-209	1	REDUCER (12N-08NF)	
26.	115-148	2	ALL THREAD (08N)	
27.	115-115	2	STREET ELBOW (08N-08NF90)	
28.	159-241	1	STRAINER SCREEN	
29.	115-139	1	NIPPLE (06N-4")	
30.	115-242	1	CAP (06NF)	
31.	155-202	1	REDUCER (12N-08NF)	

FOOTNOTES

REFER TO O-RING CHART (800-301) IN BACK OF THE BOOK FOR REPLACEMENT OF SAE AND ORS O-RINGS.

WATER PUMP SOLID SHAFT

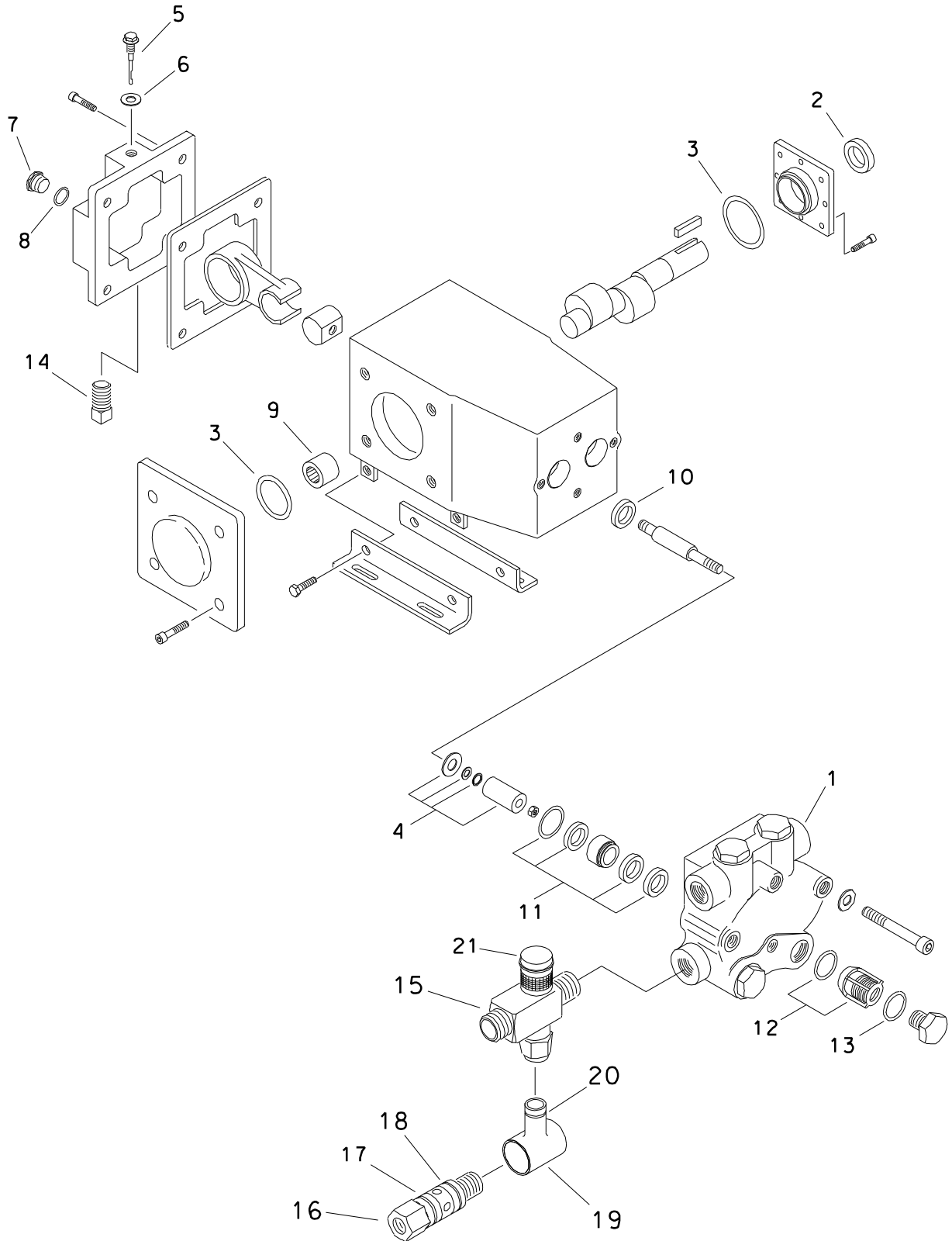

WATER PUMP SOLID SHAFT

REF NO.	PART NUMBER	QTY	DESCRIPTION	REMARKS
	158-386		WATER PUMP	INCL REF NO.'S 1 THRU 21
1.	500-769	1	HEAD	
2.	157-676	1	EXTERNAL SEAL (.750")	
3.	157-088	2	O-RING (133 D70)	
4.	500-843	2	PLUNGER REPAIR KIT	
5.	110-696	1	DIPSTICK	
6.	165-780	1	GASKET	
7.	110-695	1	SIGHT GLASS	
8.	165-779	1	GASKET	
9.	126-066	1	NEEDLE BEARING(.787")	
10.	157-610	2	INTERNAL SEAL (.550")	
11.	500-768	2	PLUNGER SEAL REPAIR KIT	
12.	500-767	1	VALVE SEAL REPAIR KIT	REPAIRS 4 VALVES
13.	155-792	4	O-RING (212 D70)	
14.	115-153	1	PLUG (04N)	
15.	500-809	1	UNLOADER VALVE	
	500-770		SEAL REPAIR KIT	INCL REF NO. 21
	117-043	1	COMPRESSION SPRING	
	500-811	1	SPRING BUTTON	
16.	500-807	1	PORT ADAPTER	
17.	500-750	1	O-RING (118 D70)	
18.	157-050	1	O-RING (116 D70)	
19.	500-808	1	BYPASS ADAPTER	
20.	157-098	1	O-RING (111 D70)	
21.	500-810	1	ADJUSTMENT NUT	

FOOTNOTES

MUD PUMP PLUMBING

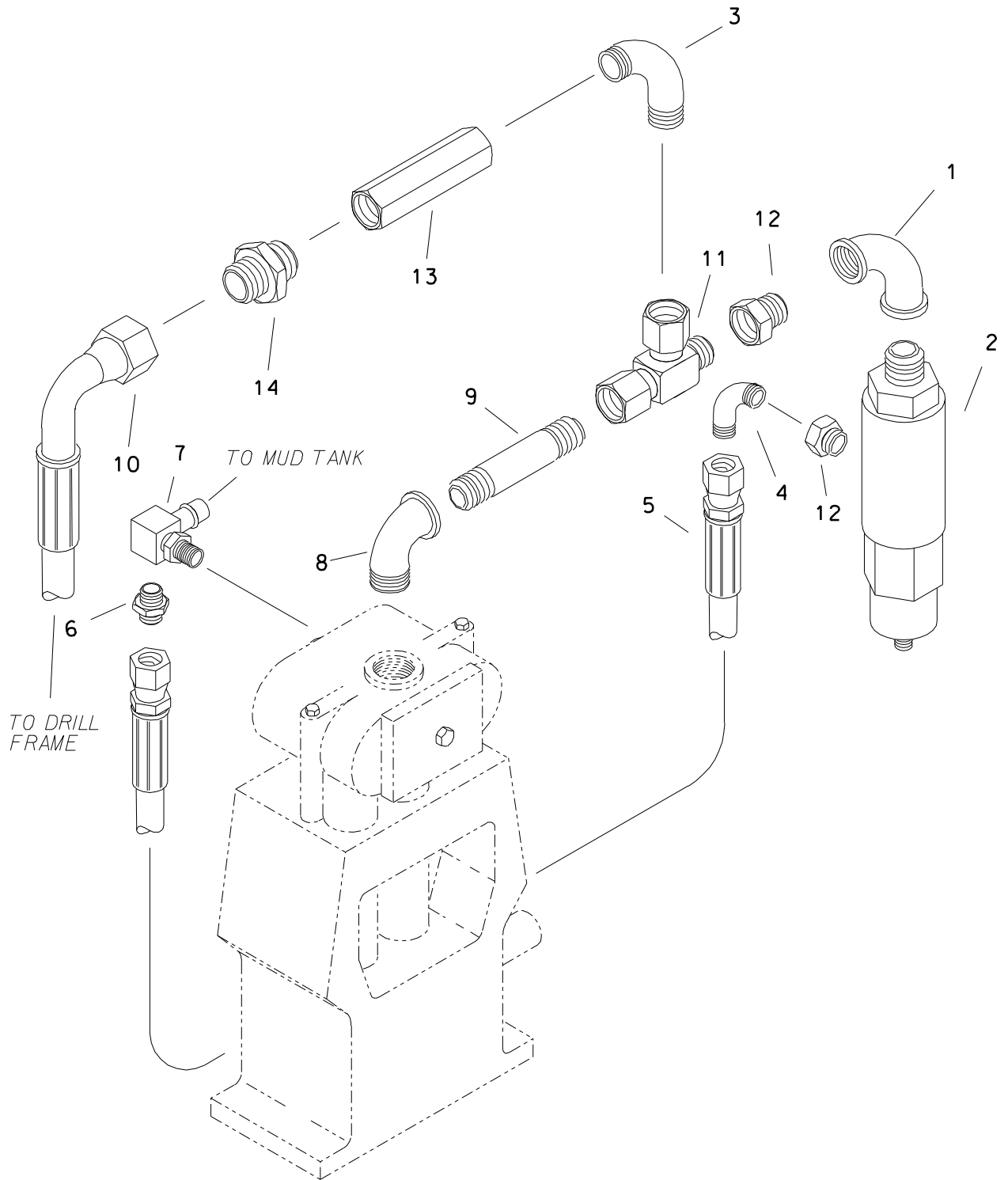

MUD PUMP PLUMBING

REF NO.	PART NUMBER	QTY	DESCRIPTION	REMARKS
1.	115-208	1	ELBOW (16N-16N90)	
2.	156-074	1	MUD RELIEF VALVE	
- -	117-223	1	SPRING	
- -	157-204	1	O-RING	
- -	157-205	1	O-RING	
- -	157-206	1	O-RING	
- -	499-098	1	BALL & SEAT	
- -	499-099	1	BALL KEEPER	
3.	115-442	1	PIPE ELBOW (08NF-12NF90)	
4.	154-352	1	CONNECTOR (08N-08090)	
5.	154-828	1	HOSE (08QFX-43MM-207BAR) HOSE (08QFX-17"-3000PSI)	
6.	154-349	1	CONNECTOR (08N-08N)	
7.	156-075	1	SLIP-ON COUPLER (SPECIAL)	
8.	115-115	1	STREET ELBOW (08N-08NF90)	
9.	115-161	1	NIPPLE (08N-3.5")	
10.	515-196	1	HOSE (08QFX90-432MM-207BAR) HOSE (08QFX90-17"-3000PSI)	
11.	155-042	1	SERVICE TEE (08N-08NF-08NF)	
12.	115-276	2	REDUCER (16N-08NF)	
13.	159-160	1	FLOW CHECK (12NF-12NF)	
14.	154-354	1	CONNECTOR (12N-080)	

FOOTNOTES

HYDRAULIC CYLINDER
3.0" ID BARREL X 1.50" OD ROD X 4.0" STROKE

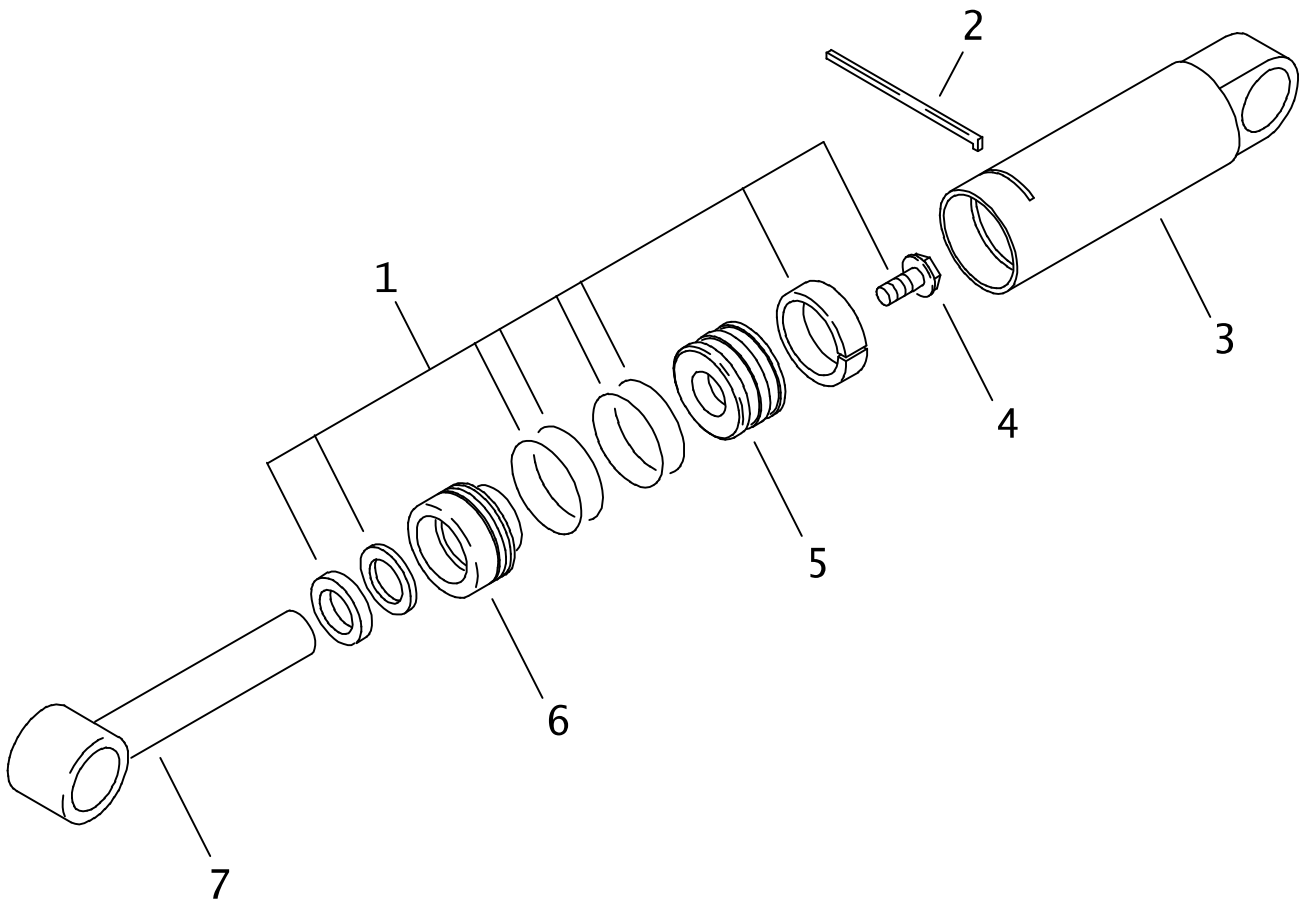

HYDRAULIC CYLINDER

3.0" ID BARREL X 1.50" OD ROD X 4.0" STROKE

REF NO.	PART NUMBER	QTY	DESCRIPTION	REMARKS
	151-054		CYL (3.0" X 1.50" X 4.0")	INCLUDES REF NO.'S 1 THRU 7
1.	190-167	1	SEAL REPAIR KIT (3.0" X 1.50")	
2.	150-911	1	LOCK RING (3")	
3.	152-004	1	CYLINDER BARREL (3")	
4.	106-098	1	FLG BOLT (3/4-NC X 2",GD 8)	SEE FOOTNOTE 1
5.	150-777	1	CYL PISTON (3.0" X 1.50")	
6.	150-774	1	CYL HEAD (3")	
7.	150-434	1	CYL ROD (1-1/2")	

NOT SHOWN:

259-040	U-SEAL INSTALLER (1.500" - UP)
259-237	ROD WIPER INSTALLER (1.5")
259-065	PISTON SEAL INSTALLER (3")
259-066	PISTON INSTALLER (3")
259-188	CYL HEAD SPANNER-TWO PIN

FOOTNOTES:

- I. USE LOCTITE 277, TORQUE TO 290-325 FT-LBS (395-440 N.M)

NOTE:

HYDRAULIC CYLINDER

2.0" ID BARREL X 1.00" OD ROD X 10.0" STROKE

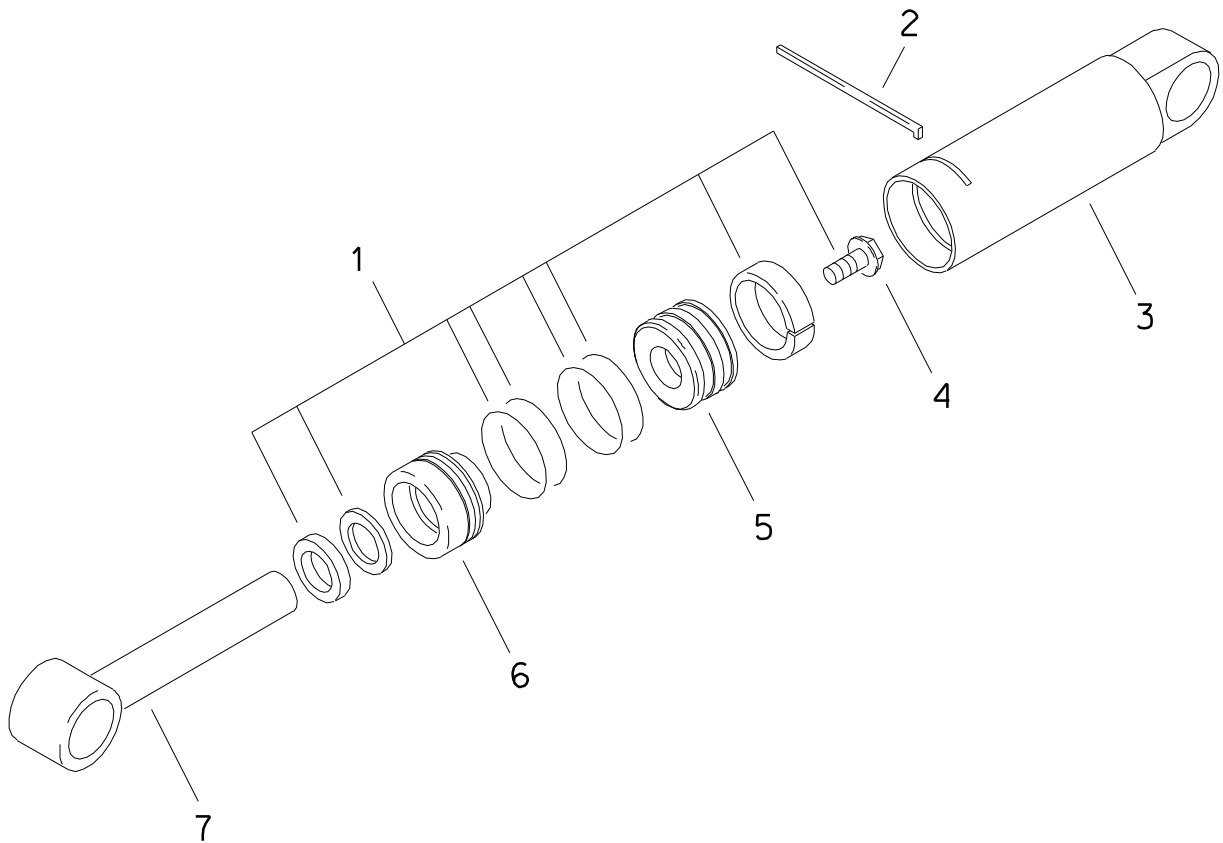

HYDRAULIC CYLINDER

2.0" ID BARREL X 1.00" OD ROD X 10.0 STROKE

REF NO.	PART NUMBER	QTY	DESCRIPTION	REMARKS
	151-076		CYLINDER (2.0 X 1.0 X 10.0)	INCLUDES REF NO.'S 1 THRU 7
1.	190-165	1	SEAL REPAIR KIT (2.0" X 1.0")	
2.	150-778	1	LOCK RING (2")	
3.	152-017	1	CYLINDER BARREL	
4.	106-096	1	FLG BOLT (1/2-NC X 1-3/4", GD8)	SEE FOOTNOTE 1
5.	150-775	1	CYL PISTON (2.0" X 1.0")	
6.	150-772	1	CYLINDER HEAD (2.0" X 1.0")	
7.	150-444	1	CYLINDER ROD	

NOT SHOWN:

259-100	U-SEAL INSTALLER (1"-1.499")
259-235	WIPER INSTALLER (1")
259-239	WIPER/SEAL INSTALLER (2")
259-241	PISTON INSTALLER (2")
259-188	CYLINDER HEAD SPANNER-TWO PIN

FOOTNOTES

1-LUBRICATE WITH WD-40 OR EQUAL. TORQUE TO 90-100 FT-LBS (120-135 N.M)

HYDRAULIC CYLINDER
3.0" ID BARREL X 1.50" OD ROD X 20.0" STROKE

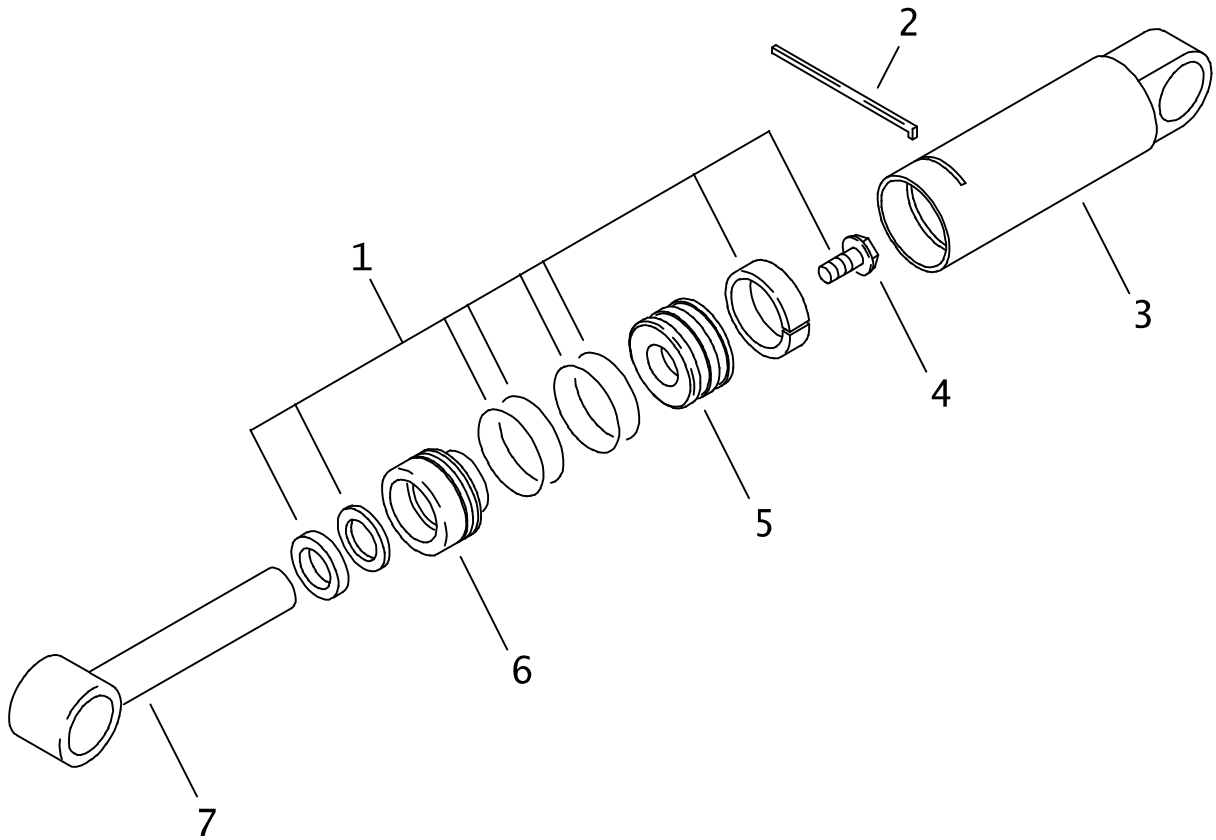

HYDRAULIC CYLINDER

3.0" ID BARREL X 1.50" OD ROD X 20.0" STROKE

REF NO.	PART NUMBER	QTY	DESCRIPTION	REMARKS
	151-117		CYLINDER (3.0 X 1.5 X 20.0)	INCLUDES REF NO.'S 1 THRU 7
1.	190-167	1	SEAL REPAIR KIT (3.0" X 1.5")	
2.	150-911	1	LOCK RING (3")	
3.	150-667	1	CYLINDER BARREL	
4.	106-098	1	FLG BOLT (3/4-NC X 2",GD 8)	SEE FOOTNOTE 1
5.	150-777	1	CYL PISTON	
6.	150-774	1	CYLINDER HEAD	
7.	150-669	1	CYLINDER ROD	

NOT SHOWN:

259-040	U-SEAL INSTALLER (1.5"-UP)
259-237	ROD WIPER INSTALLER (1.5")
259-065	PISTON SEAL INSTALLER (3")
259-066	PISTON INSTALLER (3")
259-188	CYLINDER HEAD SPANNER-TWO PIN

FOOTNOTES:

- I. USE LOCTITE 277, TORQUE TO 290-325 FT-LBS (395-440 N, M)

NOTE:

HYDRAULIC MOTOR ROTATION

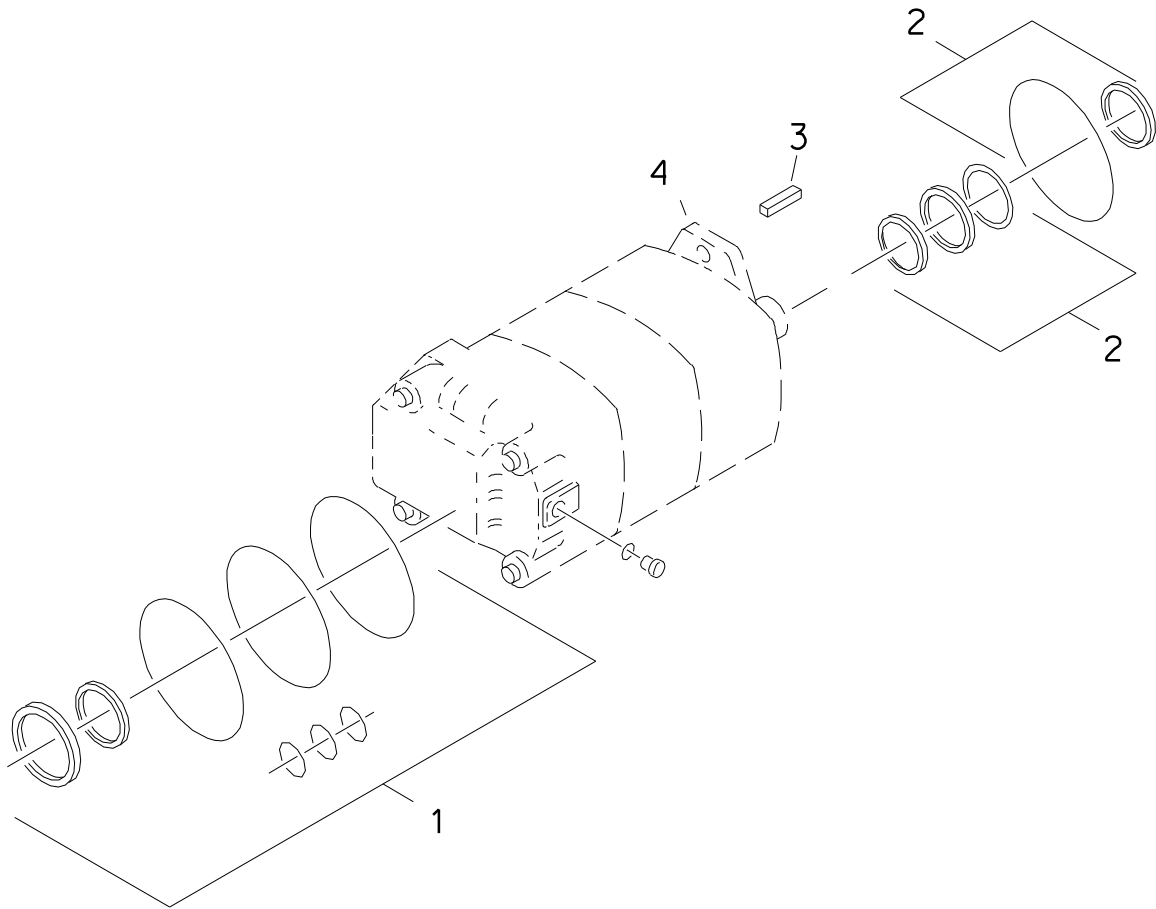

HYDRAULIC MOTOR ROTATION

REF NO.	PART NUMBER	QTY	DESCRIPTION	REMARKS
	158-724		HYDRAULIC MOTOR	INCL REF NO.'S 1 THRU 4
1.	500-711	1	SEAL REPAIR KIT-MOTOR	
2.	500-712	1	SEAL REPAIR KIT-SHAFT	SEE FOOTNOTE 1
	500-758	1	SEAL REPAIR KIT-SHAFT	SEE FOOTNOTE 2
3.	165-916	1	KEY (5/16" X 1-3/4")	
4.	500-461	1	MOUNT FLANGE	

FOOTNOTES

- 1. FOR -004 REVISION CODE MOTORS.
- 2. FOR -006 REVISION CODE MOTORS.

NOTES

REVISED CODES ARE THE LAST THREE DIGITS IN THE PRODUCT CODE SHOWN ON THE TAG ATTACHED TO THE MOTOR.

NOTES:

ELECTRICAL

ELECTRICAL STRIKE SYSTEM

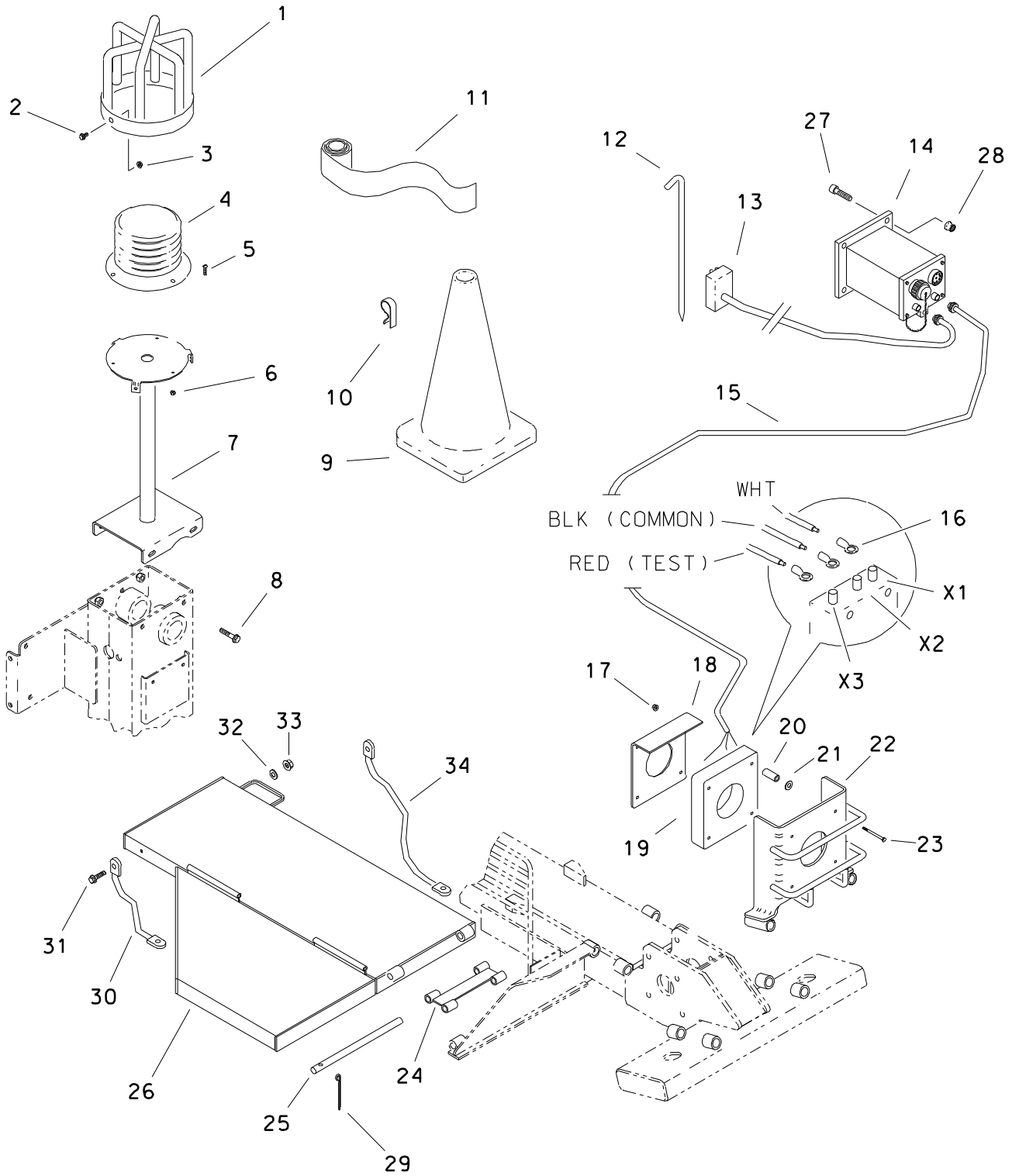

ELECTRICAL STRIKE SYSTEM

REF NO.	PART NUMBER	QTY	DESCRIPTION	REMARKS
1.	362-620	1	LIGHT COVER	
2.	105-836	3	FLG LK BOLT (1/4-NC X 1/2")	
3.	105-832	3	FLG LOCKNUT (1/4-NC)	
4.	217-041	1	STROBE LIGHT	
	217-720	1	REPLACEMENT BULB	
5.	105-185	3	SCREW (#10-24 X 1/2, RH SLT)	
6.	106-048	3	LOCKNUT (#10-24)	
7.	363-507	1	LIGHT POST	
8.	105-825	4	FLG LK BOLT (3/8-NC X 3/4")	
9.	259-210	8	TRAFFIC CONE - ORANGE	
10.	259-234	8	CONE CLIP	
11.	260-223	1	BARRIER TAPE (1,000', YELLOW)	
12.	215-799	1	VOLTAGE STAKE	
13.	216-032	1	ESS VOLT LIMITER	
14.	214-429	1	CONTROL MODULE	
	197-431		CONTROLLER	
15.	214-173	1	ESS CABLE (3.7 MM)	
16.	215-476	3	RING TERMINAL (#10)	
17.	106-353	4	FLG NUT (M6 X 1.0)	
18.	362-623	1	COIL COVER BACK	
19.	216-023	1	CURRENT TRANSFORMER	SEE FOOTNOTE 1
20.	116-376	4	SPACER	
21.	116-283	4	RUBBER WASHER	
22.	355-478	1	COIL COVER	
23.	105-843	4	BOLT (M6-1.00 X 80MM)	
24.	353-165	1	LINKAGE	
25.	353-159	2	ROD	
26.	353-164	1	STRIKE MAT	
27.	106-640	4	SCREW (M6-1.00 X 20MM, SOC BTN)	
28.	106-670	4	NUTSERT (M6-1.00)	
29.	105-523	4	COTTER PIN (1/8" X 3/4")	
30.	214-088	1	CABLE	
31.	106-217	4	BOLT (1/4-NC X 1", SIL BRZ)	
32.	106-221	4	STAR WASHER (1/4" SIL BRZ)	
33.	106-219	4	NUT (1/4-NC SIL BRZ)	
34.	214-087	1	CABLE	

FOOTNOTES

1. REF 19 OBSOLETE, 216-023 REPLACED WITH 101-143.

GROUNDING CABLES

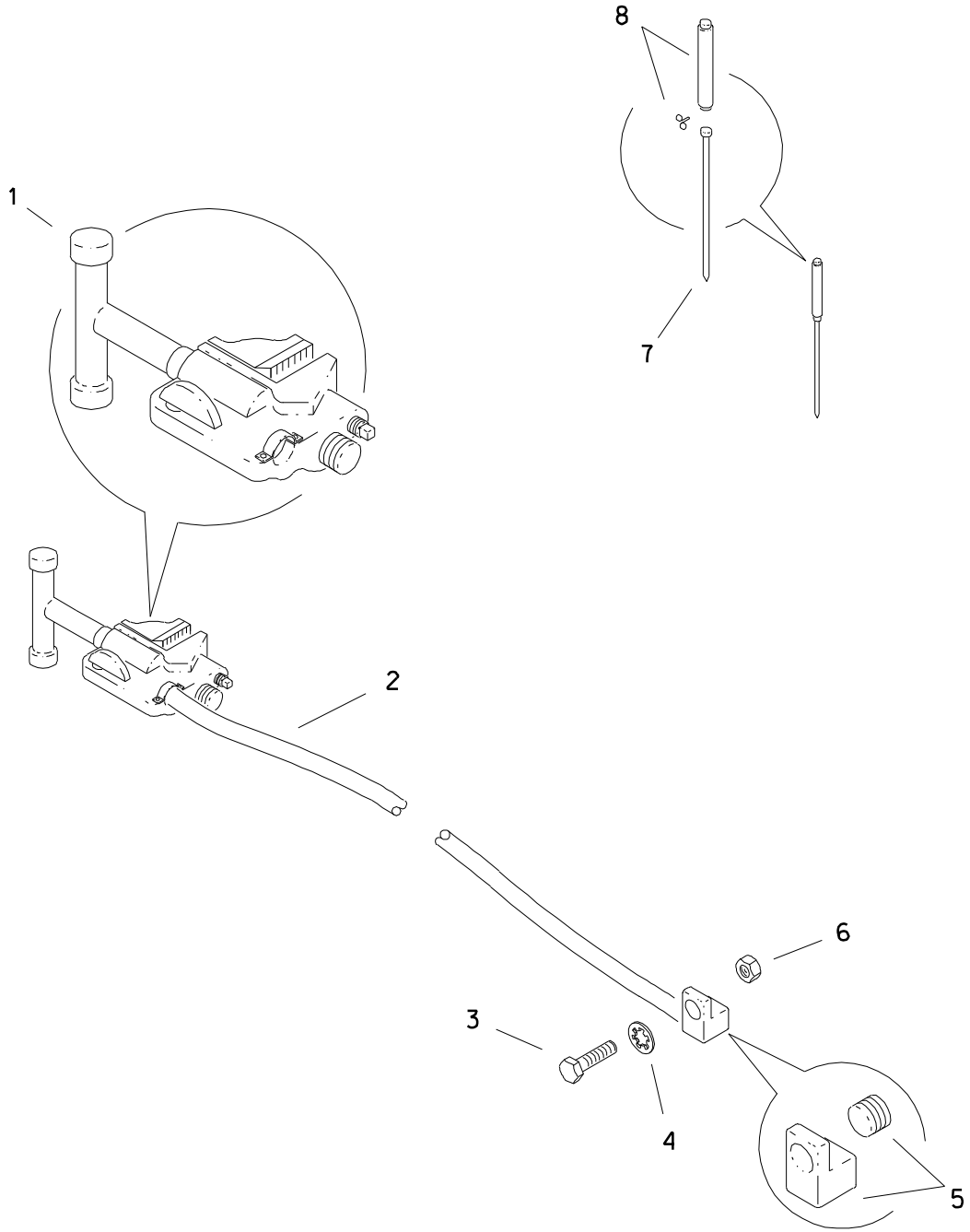

GROUNDING CABLES

REF NO.	PART NUMBER	QTY	DESCRIPTION	REMARKS
1	215-769	1	GROUND CLAMP	
2	215-813	1	GROUND CABLE (1/0 GA X 25')	INCL REF NO.'S 1 AND 5
	215-768	AR	GROUND CABLE (1/0 GA)	USE 25 FT
3	106-462	1	BOLT (3/8-NC X 1-1/4", SIL BRZ)	
4	106-220	1	INT STAR WASHER (3/8", SIL BRZ)	
5	215-773	1	RING LUG TERMINAL (27/64")	
6	106-454	1	LOCKNUT (3/8-NC, SIL BRZ)	
7	215-775	1	GROUND ROD	
8	215-776	1	SLIDE DRIVER	

FOOTNOTES

CONSOLE GAUGES JT820

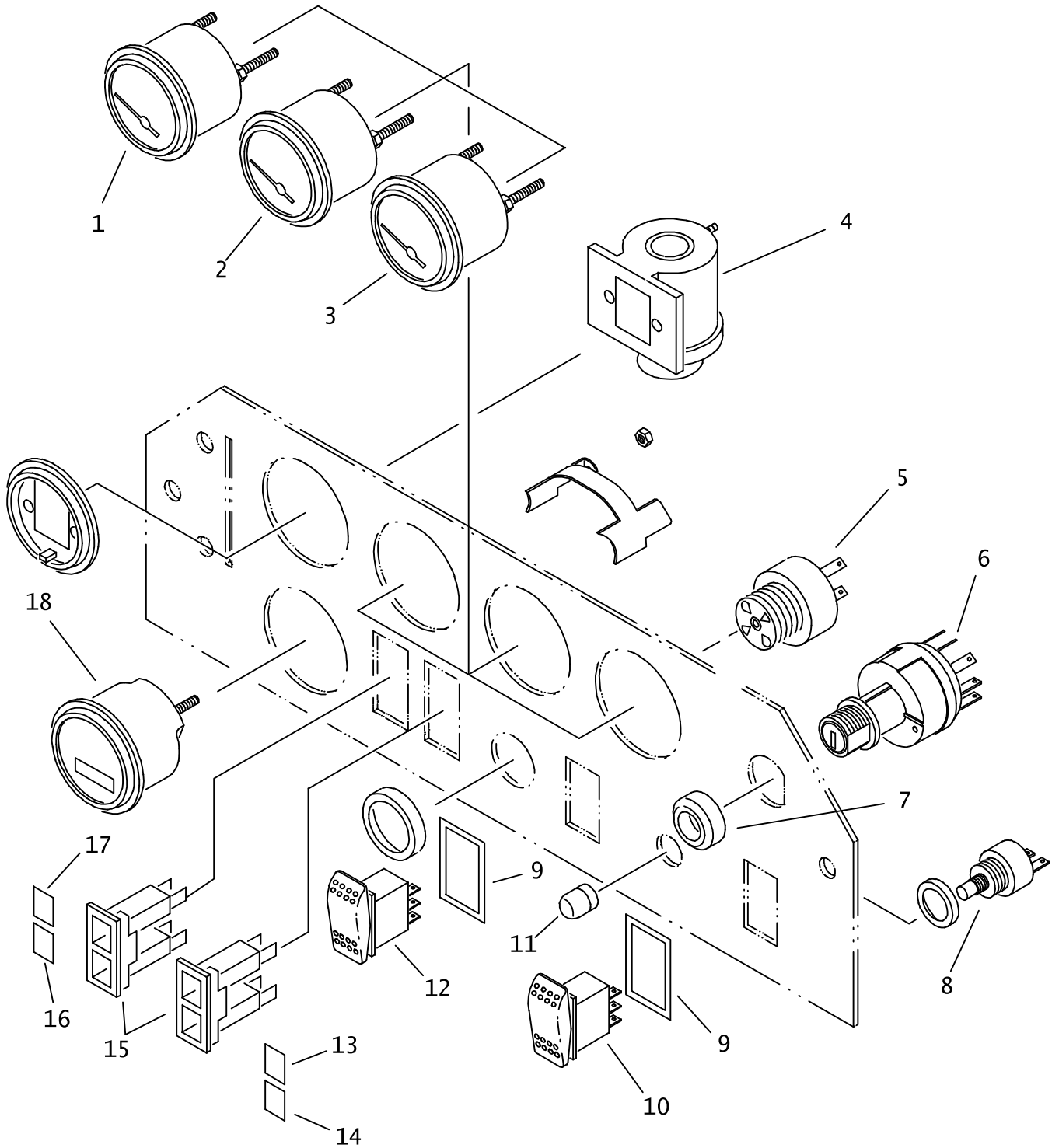

CONSOLE GAUGES

JT820

REF NO.	PART NUMBER	QTY	DESCRIPTION	REMARKS
1.	215-133	1	FUEL GAUGE	
2.	215-129	1	VOLT METER	
3.	215-132	1	WATER TEMPERATURE GAUGE	
4.	215-150	1	FILTER MINDER	
5.	306-603	1	AUDIO ALARM	
6.	214-852	1	IGNITION SWITCH	
	214-961		KEY, PAIR	
	214-962		SWITCH MOUNTING NUT	
	217-769	1	KEYS (PAIR)	
7.	106-521	1	BEZEL NUT (1-NS)	
8.	306-607	1	HORN BUTTON	
9.	165-817	2	SWITCH GASKET	
10.	217-789	1	ROCKER SWITCH	
11.	306-608	1	HORN BUTTON CAP	
12.	217-762	1	ROCKER SWITCH (SEALED)	
13.	217-036	1	INSERT - HYD OIL PSI (YEL)	
14.	217-028	1	INSERT - BLANK (BLK)	
15.	217-020	2	PILOT LIGHT	
	217-046	1	REPLACEMENT BULB	
16.	217-027	1	INSERT - HYD OIL HI TEMP (RED)	
17.	217-021	1	INSERT - ENG OIL PSI (RED)	
18.	215-128	1	HOUR METER	

NOT SHOWN:

FOOTNOTES:

NOTE:

OPERATORS STATION GAUGES

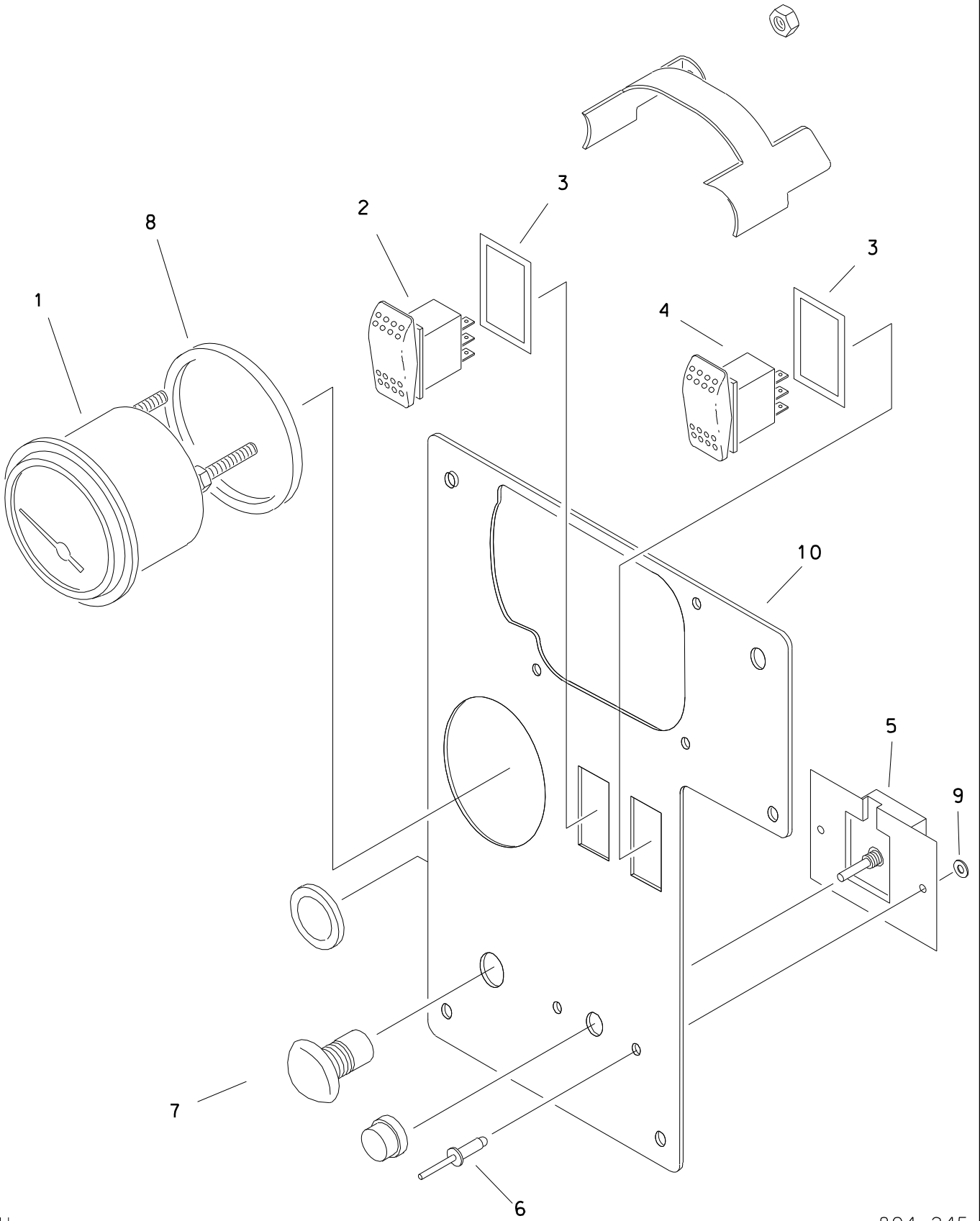

OPERATORS STATION GAUGES

REF NO.	PART NUMBER	QTY	DESCRIPTION	REMARKS
1.	217-543	1	PRESSURE GAUGE (3000 PSI)	
2.	217-854	1	SWITCH	
3.	165-817	2	SWITCH GASKET	
4.	217-762	1	ROCKER SWITCH (SPDT)	
5.	217-902	1	FLUID FLOW POTENTIOMETER	
6.	110-560	2	POP RIVET (3/16" X 1/2", ALUM)	
7.	<u>217-724</u>	1	BUTTON SWITCH (SPST)	
	214-943	1	BUTTON SWITCH (SPST)	
8.	165-514	1	SHIM (3" O.D X 2-3/4" ID)	
9.	106-205	2	WASHER (.191")	
10.	353-789	-	COVER PLATE	

FOOTNOTES

RELAY PANEL

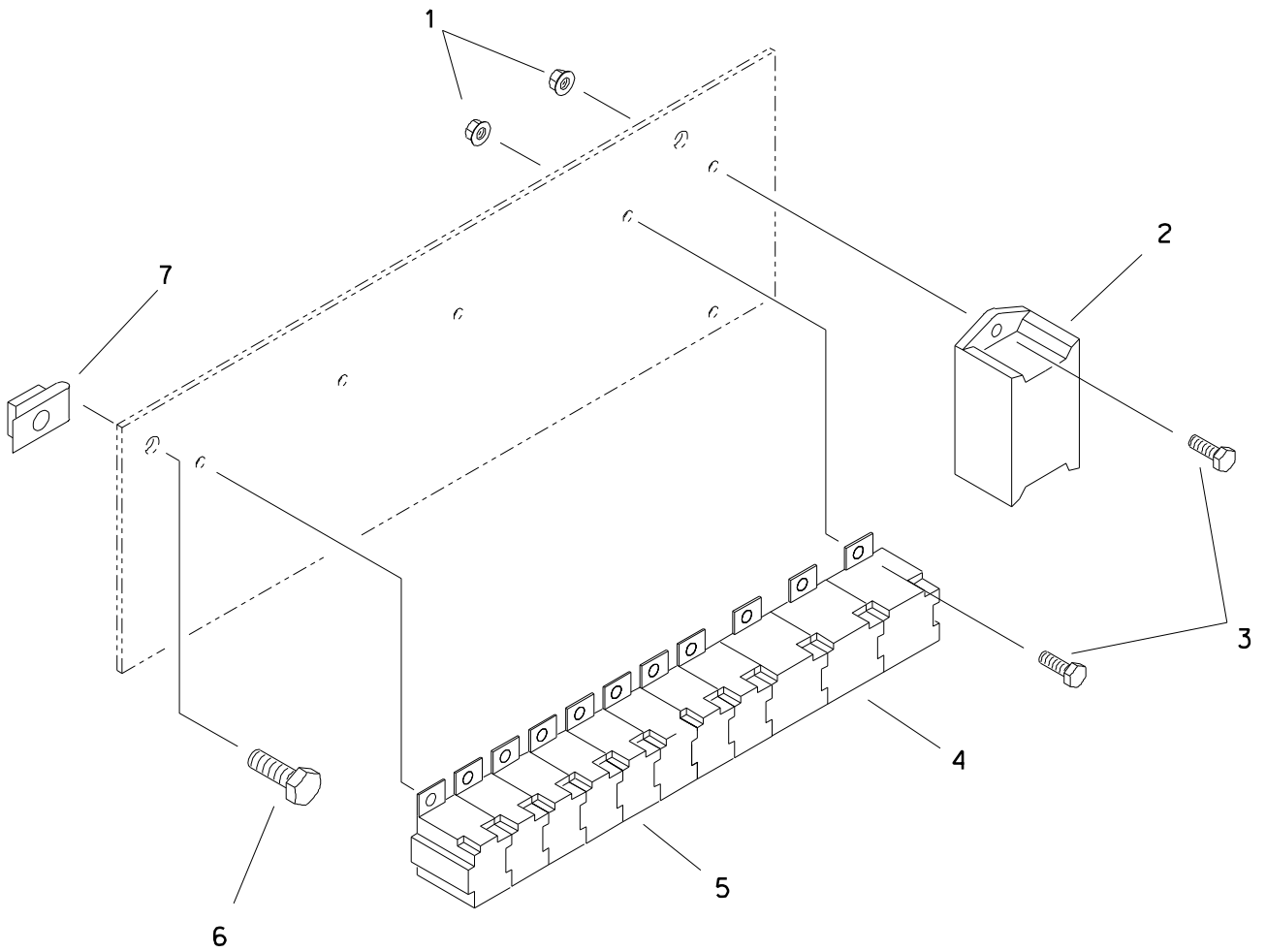

RELAY PANEL

REF NO.	PART NUMBER	QTY	DESCRIPTION	REMARKS
1.	106-048	6	LOCKNUT (#10-24)	
2.	217-804	1	START BYPASS DELAY	
3.	105-185	6	SCREW (#10-24 X 1/2, RD SLT)	
4.	217-826	3	MINI RELAY	
5.	217-710	8	MICRO RELAY	
6.	106-381	2	FLG LK SCREW (M8-1.25 X 25MM)	
7.	106-551	2	CLIP NUT (M8-1.25)	

FOOTNOTES

ELECTRICAL DIAGRAM ENGINE/FRAME HARNESS

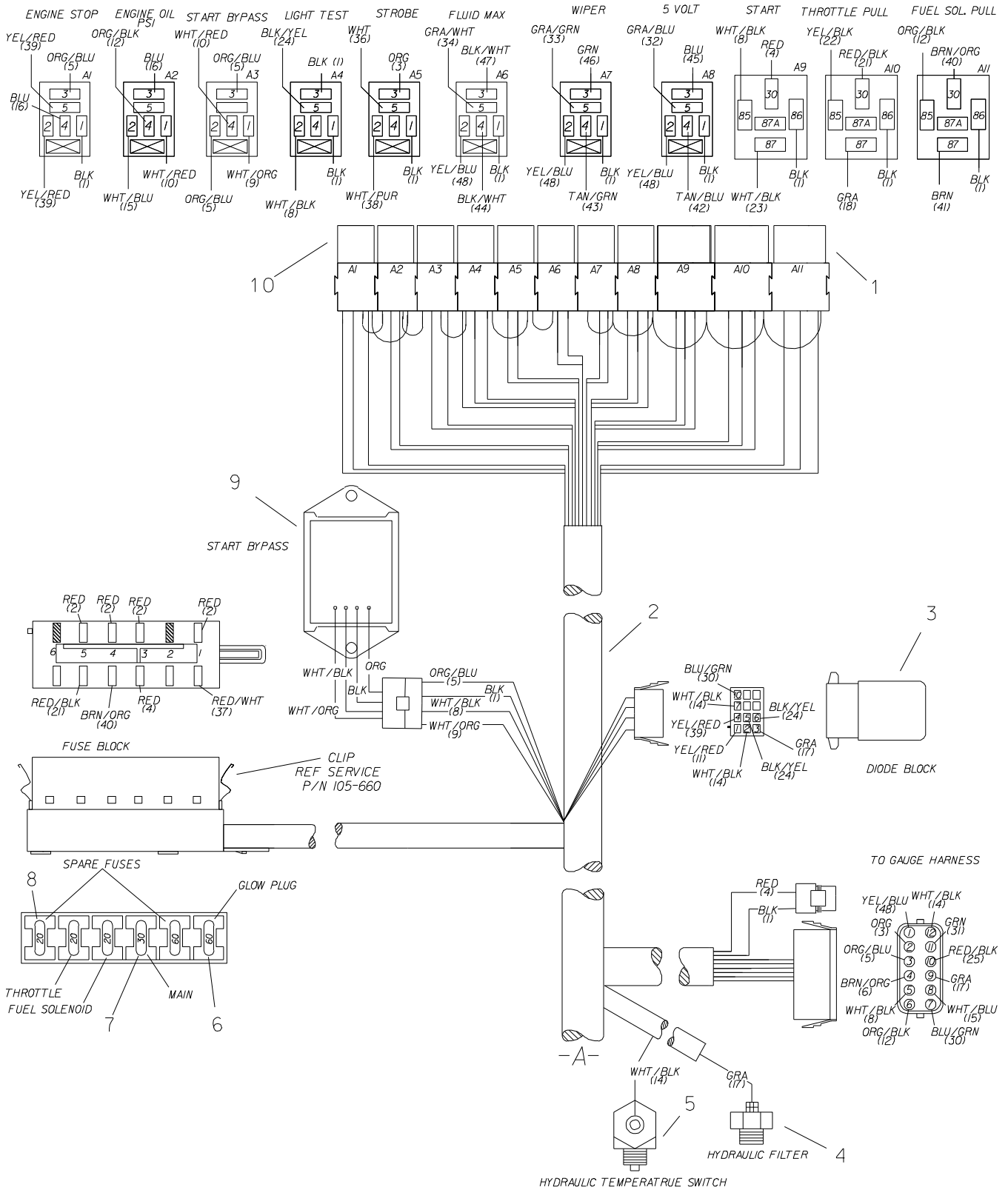

ELECTRICAL DIAGRAM ENGINE/FRAME HARNESS

REF NO.	PART NUMBER	QTY	DESCRIPTION	REMARKS
1.	217-826	3	MINI RELAY	
	105-185	4	SCREW (#10-24 X 1/2, RD SLT)	
	106-048	4	LOCKNUT (#10-24)	
2.	214-074	1	ENGINE/FRAME HARNESS	
	110-030	AR	CABLE TIE (1/16" TO 4")	
3.	216-521	1	DIODE BLOCK	
4.	217-765	1	HYDRAULIC FILTER SWITCH	
5.	215-148	1	TEMPERATURE SWITCH	
6.	217-793	2	FUSE (60 A)	
7.	217-806	1	FUSE (30 A)	
8.	217-805	3	FUSE (20 A)	
9.	217-804	1	START BYPASS DELAY	
	105-185	2	SCREW (#10-24 X 1/2, RH SLT)	
	106-048	2	LOCKNUT (#10-24)	
10.	217-710	8	MICRO RELAY	

FOOTNOTES

ALL CONNECTORS ARE SHOWN WITH REAR VIEWS

ELECTRICAL DIAGRAM ENGINE/FRAME HARNESS

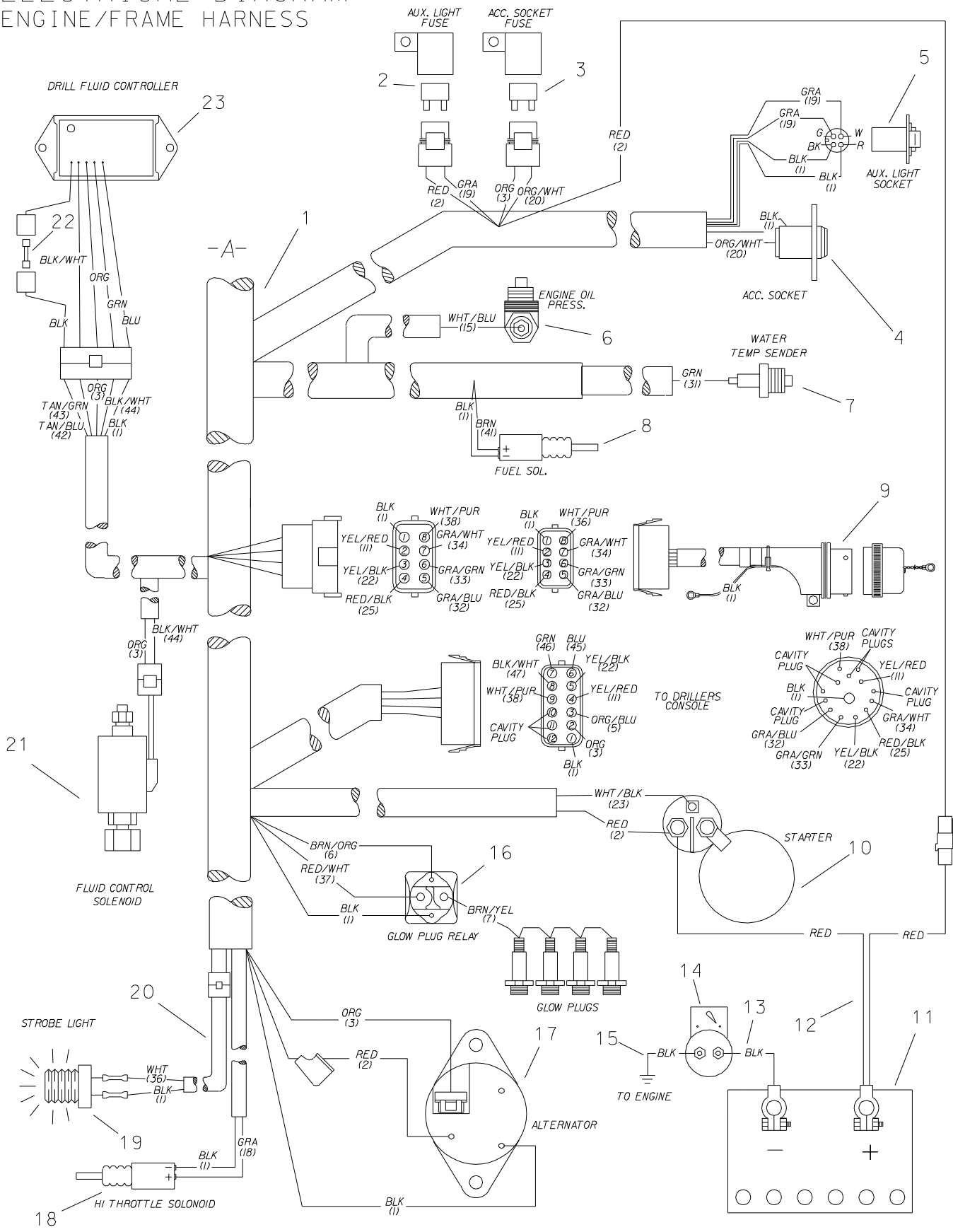

D

ELECTRICAL DIAGRAM

ENGINE/FRAME HARNESS

REF NO.	PART NUMBER	QTY	DESCRIPTION	REMARKS
1.	214-073	1	ENGINE/FRAME HARNESS	
2.	217-813		FUSE (30 A)	
3.	217-812		FUSE (20 A)	
4.	217-017	1	ACCESSORY SOCKET	
	105-185	2	SCREW (#10-24 X 1/2, RH SLT)	
	106-048	2	LOCKNUT (#10-24)	
5.	214-107	1	FEMALE CONNECTOR (4-WAY)	
	105-185	2	SCREW (#10-24 X 1/2, RH SLT)	
	106-048	2	LOCKNUT (#10-24)	
6.	217-736	1	OIL PRESSURE SWITCH	
7.	215-179	1	SENDER	
8.	217-862	1	FUEL SOLENOID	
9.	214-172	1	UMBILICAL HARNESS	
	106-216	1	BOLT (3/8-NC X 1", SIL BRZ)	
	106-454	1	LOCKNUT (3/8-NC, SIL BRZ)	
	106-220	1	STAR WASHER (3/8", SIL BRZ)	
10.	194-407	1	STARTER	
11.	215-275	1	BATTERY	
12.	215-370	1	BATTERY CABLE (1/0 GA X 1170MM)	
			BATTERY CABLE (1/0 GA X 46")	
13.	215-337	1	BATTERY CABLE (2/0 GA X 483MM)	
			BATTERY CABLE (2/0 GA X 19")	
14.	217-819	1	BATTERY DISCONNECT SWITCH	
15.	215-375	1	BATTERY CABLE (1/0 GA X 610MM)	
			BATTERY CABLE (1/0 GA X 24")	
	106-381	1	FLG LK SCREW (M8-1.25 X 25MM)	
	106-220	1	STAR WASHER (3/8", SIL BRZ)	
16.	217-855	1	SOLENOID SWITCH	SEE FOOTNOTE #2
	215-010	1	SOLENOID COVER	
	105-836	2	FLG LK BOLT (1/4-NC X 1/2")	
	105-832	2	FLG LOCKNUT (1/4-NC)	
17.	215-159	1	ALTERNATOR	
18.	217-857	1	THROTTLE SOLENOID	
19.	217-041	1	STROBE LIGHT	
	217-720	1	REPLACEMENT BULB	
20.	214-175	1	STROBE PIGTAIL HARNESS	
21.	217-864	1	ELECTRONIC SOLENOID	
22.	215-036	1	FUSE (2 A)	
23.	215-914	1	DRILL FLUID CONTROLLER	
	105-185	2	SCREW (#10-24 X 1/2, RD SLT)	
	106-048	2	LOCKNUT (#10-24)	

FOOTNOTES

- ALL CONNECTORS ARE SHOWN WITH REAR VIEWS
- AFTER S/N , INSTALLTION OF NEW SOLENOID WILL REQUIRE ONE (1) 214-281 GROUND WIRE JUMPER

ELECTRICAL DIAGRAM OPERATORS CONSOLE HARNESS

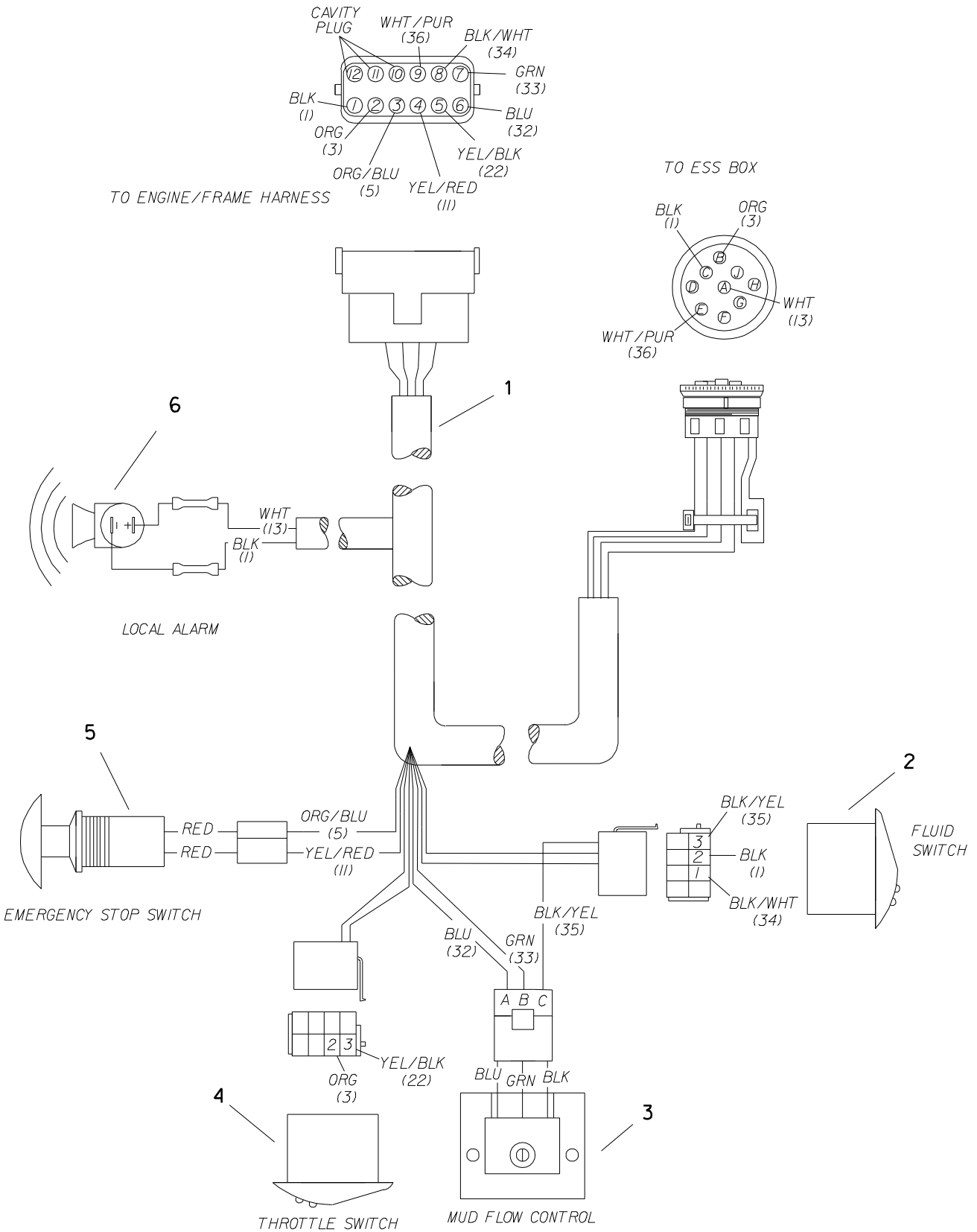

ELECTRICAL DIAGRAM OPERATORS CONSOLE HARNESS

REF NO.	PART NUMBER	QTY	DESCRIPTION	REMARKS
1.	214-150	1	OPERATORS HARNESS	
2.	217-854	1	ROCKER SWITCH (3 POSITION)	ON-OFF-ON
	165-817	2	SWITCH GASKET	
3.	217-902	1	FLUID FLOW POTENTIOMETER	
	110-641	1	KNOB (1/8", BLACK)	
	110-560	2	POP RIVET (3/16" X 1-1/2")	
4.	217-762	1	ROCKER SWITCH (2 POSITION)	ON-ON
5.	217-724	1	BUTTON SWITCH	
	215-754	2	MC INSULATOR (2 TERMINAL)	
6.	306-602	1	BACKUP ALARM	
	105-827	2	FLG LK BOLT (3/8-NC X 1-1/4")	
	105-845	2	FLG LOCKNUT (3/8-NC)	

FOOTNOTES

ALL CONNECTORS ARE SHOWN WITH REAR VIEWS

ELECTRICAL DIAGRAM GAUGE HARNESS JT820

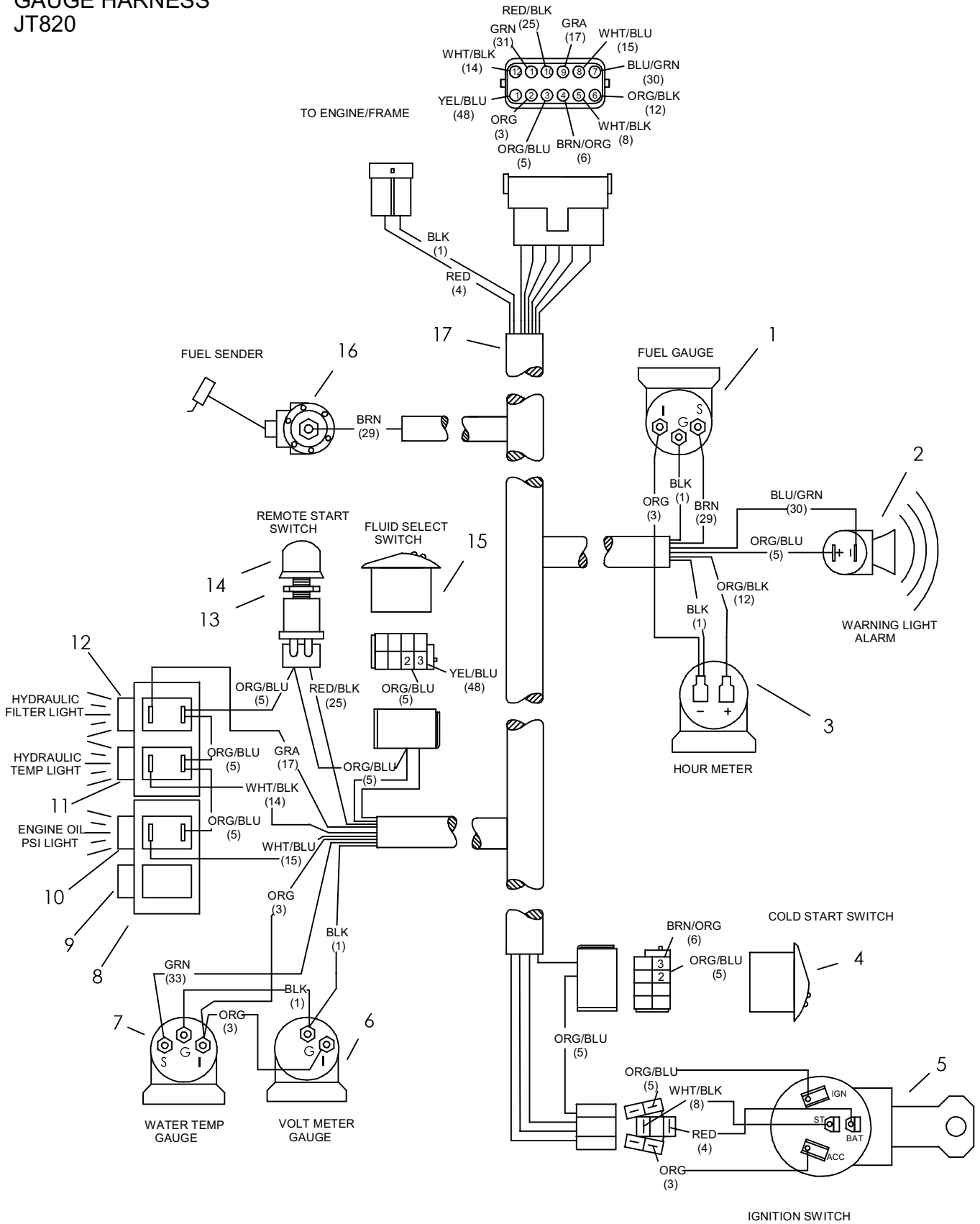

ELECTRICAL DIAGRAM

GAUGE HARNESS

JT820

REF NO.	PART NUMBER	QTY	DESCRIPTION	REMARKS
1.	215-133	1	FUEL GAUGE	
2.	306-603	1	AUDIO ALARM	
3.	215-128	1	HOUR METER	
4.	217-789	1	ROCKER SWITCH	ON-MOMENTARY ON
	165-817	1	SWITCH GASKET	
5.	214-852	1	IGNITION SWITCH	
	214-961		KEY, PAIR (BASE CODE)	
	214-962		SWITCH MOUNTING NUT	
6.	215-129	1	VOLT METER	
7.	215-132	1	WATER TEMPERATURE GAUGE	
8.	217-020	2	PILOT LIGHT	
	217-020	1	REPLACEMENT BULB	
9.	217-028	1	INSERT - BLANK (BLK)	
10.	217-021	1	INSERT - ENG OIL PSI (RED)	
11.	217-027	1	INSERT - HYD OIL HI TEMP (RED)	
12.	217-036	1	INSERT - HYD OIL PSI (YEL)	
13.	306-607	1	HORN BUTTON	
14.	306-608	1	HORN BUTTON CAP	ON-ON
15.	217-762	1	ROCKER SWITCH (SEALED)	
	165-817	1	SWITCH GASKET	
16.	217-549	1	FUEL SENDER	
17.	214-073	1	GAUGE HARNESS	

NOT SHOWN:

FOOTNOTES:

NOTE:

ALL CONNECTORS ARE SHOWN WITH REAR VIEWS

ELECTRICAL SCHEMATIC

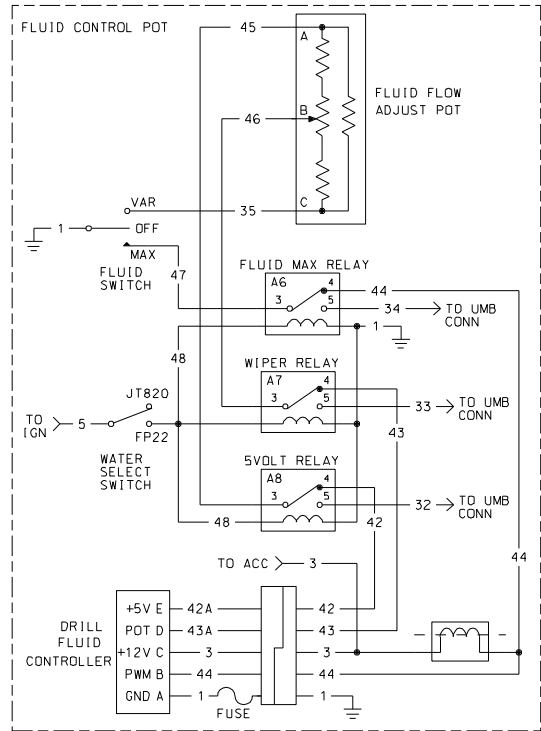
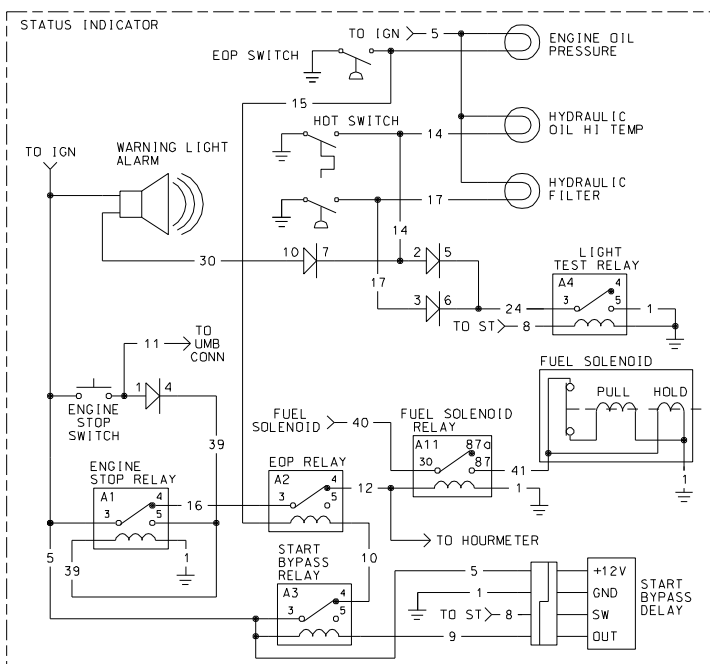
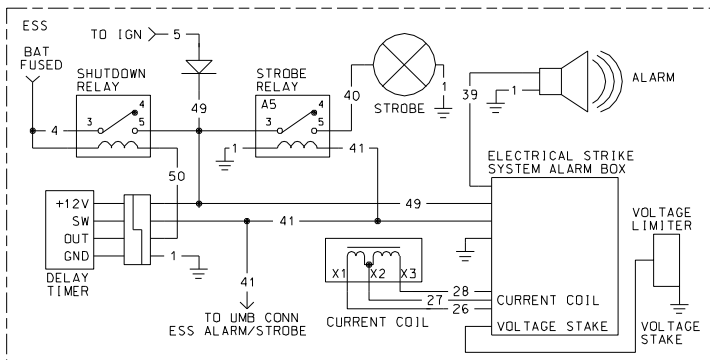
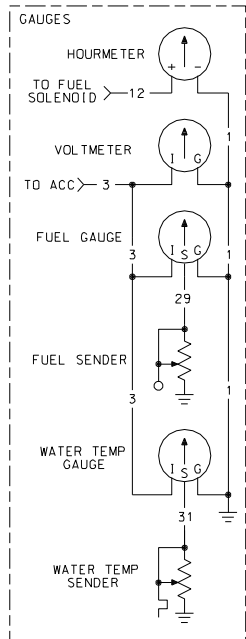
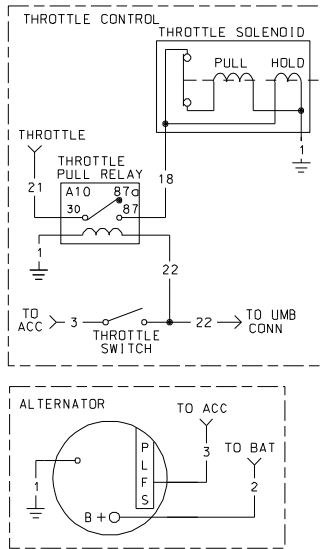
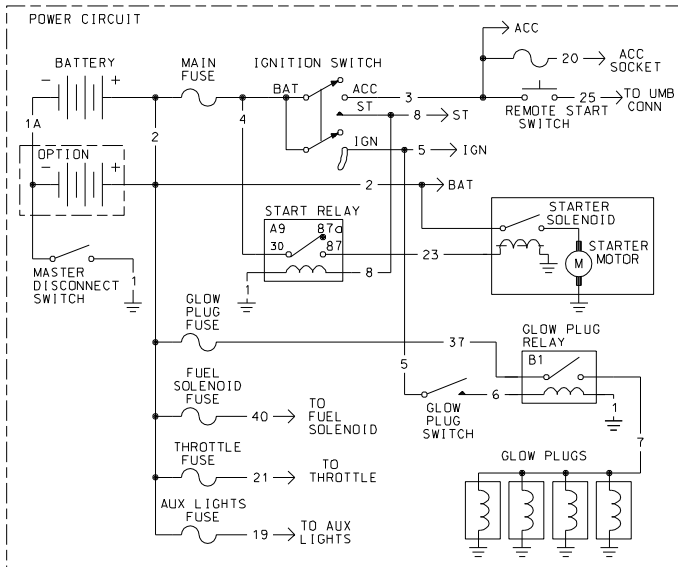

UMBILICAL CONNECTION	UMBILICAL CABLE
TO REMOTE START SWITCH	25 7 25A
TO FLUID ADJUST POT "A"	32 10 32A
TO FLUID ADJUST POT "B"	33 9 33A
TO FLUID SWITCH "MAX"	34 6 34A
TO "ESS ALARM/STROBE"	38 14 38A
TO "PP THROTTLE"	22 8 22A
TO "ENGINE STOP SWITCH"	11 4 11A
	1 1 1A

ELECTRICAL SCHEMATIC

CKT NO.	WIRE COLOR	FUNCTION	REMARKS
1	BLK	SYSTEM GROUND	
1A	BLK	UMBILICAL CABLE GROUND	
2	RED	BATTERY CIRCUIT	
3	ORG	ACCESSORY CIRCUIT	
4	RED	BATTERY CIRCUIT (FUSED)	
5	ORG/BLU	IGNITION CIRCUIT	
6	BRN/ORG	COLD START SWITCH TO COLD START RELAY	
7	BRN/YEL	COLD START RELAY TO MANIFOLD HEATER	
8	WHT/BLK	IGNITION SWITCH START TO START RELAY	
9	WHT/ORG	START BYPASS DELAY TO START BYPASS RELAY	
10	WHT/RED	START BYPASS RELAY TO EOP FUEL SHUTOFF RELAY	
11	YEL/RED	ENGINE STOP SWITCH CIRCUIT TO UMBILICAL CONN	
11A	TAN	UMBILICAL CABLE ENGINE STOP SWITCH CIRCUIT	
12	ORG/BLK	EOP RELAY TO FUEL SOLENOID & HOUR METER	
13	WHT/GRN	ESS BOX TO LOCAL ALARM	
14	WHT/BLK	HYD OIL TEMP SWITCH TO LIGHT & DIODE BLOCK	
15	WHT/BLU	ENGINE OIL PRESSURE SWITCH TO LIGHT & EOP RELAY	
16	BLU	JUMPER FROM ENGINE STOP RELAY TO EOP RELAY	
17	GRA	HYDRAULIC FILTER LIGHT CIRCUIT	
18	GRA	THROTTLE PULL RELAY TO THROTTLE SOLENOID	
19	GRA	AUX. LIGHT FUSE TO AUX. LIGHT SOCKET	
20	ORG/WHT	FUSE TO ACCESSORY SOCKET	
21	RED/BLU	THROTTLE FUSE TO THROTTLE PULL RELAY	
22	YEL/BLK	FLUID PAC THROTTLE SWITCH TO UMB CONNECTION	
22A	YEL	UMBILICAL CABLE THROTTLE SWITCH CIRCUIT	
23	WHT/BLK	START RELAY TO START SOLENOID	
24	BLKYEL	DIODE CATHODES TO LIGHT TEST RELAY	
25	RED/BLK	REMOTE START SWITCH TO UMBILICAL CONNECTOR	
25A	ORG	UMBILICAL CABLE REMOTES START SWITCH CIRCUIT	
26	WHT	ESS BOX TO CURRENT COIL X1	
27	BLK	ESS BOX TO CURRENT COIL X2	
28	RED	ESS BOX TO CURRENT COIL X3	
29	BRN	FUEL SENDER TO GAUGE	
30	TAN/BLU	HORN SWITCH TO HORN	
31	GRN	WATER TEMP SENDER TO GAUGE	
32	GRA/BLU	5VOLT RELAY TO UMBILICAL CONNECTOR	
32A	BLU	UMBILICAL CABLE FLUID FLOW ADJUST POT (5V) CIRCUIT	
33	GRA/GRN	OUTPUT RELAY TO UMBILICAL CONNECTOR	
33A	GRN	UMBILICAL CABLE FLUID FLOW ADJUST POT WIPER CKT	
34	BLU/WHT	MAX RELAY TO UMBILICAL CONNECTOR	
34A	RED	UMBILICAL CABLE FLUID SWITCH "MAX" CIRCUIT	
35	BLK/YEL	FLUID SWITCH TO FLUID POT	
36	WHT	WARNING LIGHT ALARM TO DIODE BLOCK	
37	RED/WHT	GLOW PLUG FUSE TO GLOW PLUG REALY	
38	WHT/PUR	ESS TO STROBE RELAY AND UMBILICAL CABLE	
38A	GRA	UMBILICAL CABLE ESS STROBE CIRCUIT	
39	YEL/RED	DIODE CATHODE TO ENGINE STOP RELAY (LATCH CIRCUIT)	
40	BRN/ORG	FUEL SOLENOID FUSE TO RELAY	

ELECTRICAL SCHEMATIC

CKT NO.	WIRE COLOR	FUNCTION	REMARKS
41	BRN	FUEL SOLENOID RELAY TO FUEL SOLENOID	
42	TAN/BLU	FLUID CONTROLLER 5V OUT TO 5VOLT RELAY	
42A	BLU	FLUID CONTROLLER 5V	
43	TAN/GRN	FLUID CONTROLLER POT OUT TO WIPER RELAY	
43A	GRN	FLUID CONTROLLER POT	
44	BLK/WHT	FLUID CONTROLLER PWM OUT TO VALVE GROUND & MAX RELAY	
45	BLU	FLUID FLOW ADJUST POT (5V) TO 5VOLT RELAY	
46	GRN	FLUID FLOW ADJUST POT WIPER TO WIPER RELAY	
47	BLK/WHT	FLUID SWITCH MAX TO MAX RELAY	
48	YEL/BLU	SELECTOR SWITCH TO MAX, WIPER AND 5VOLT RELAYS	
49	ORG/RED	DIODE CATHODE TO DELAY TIMER & ESS	
50	TAN/BLK	DELAY TIMER TO SHUTDOWN RELAY	

OPTIONS

ANCHOR HYDRAULICS HEAVY DUTY ANCHOR SYSTEM

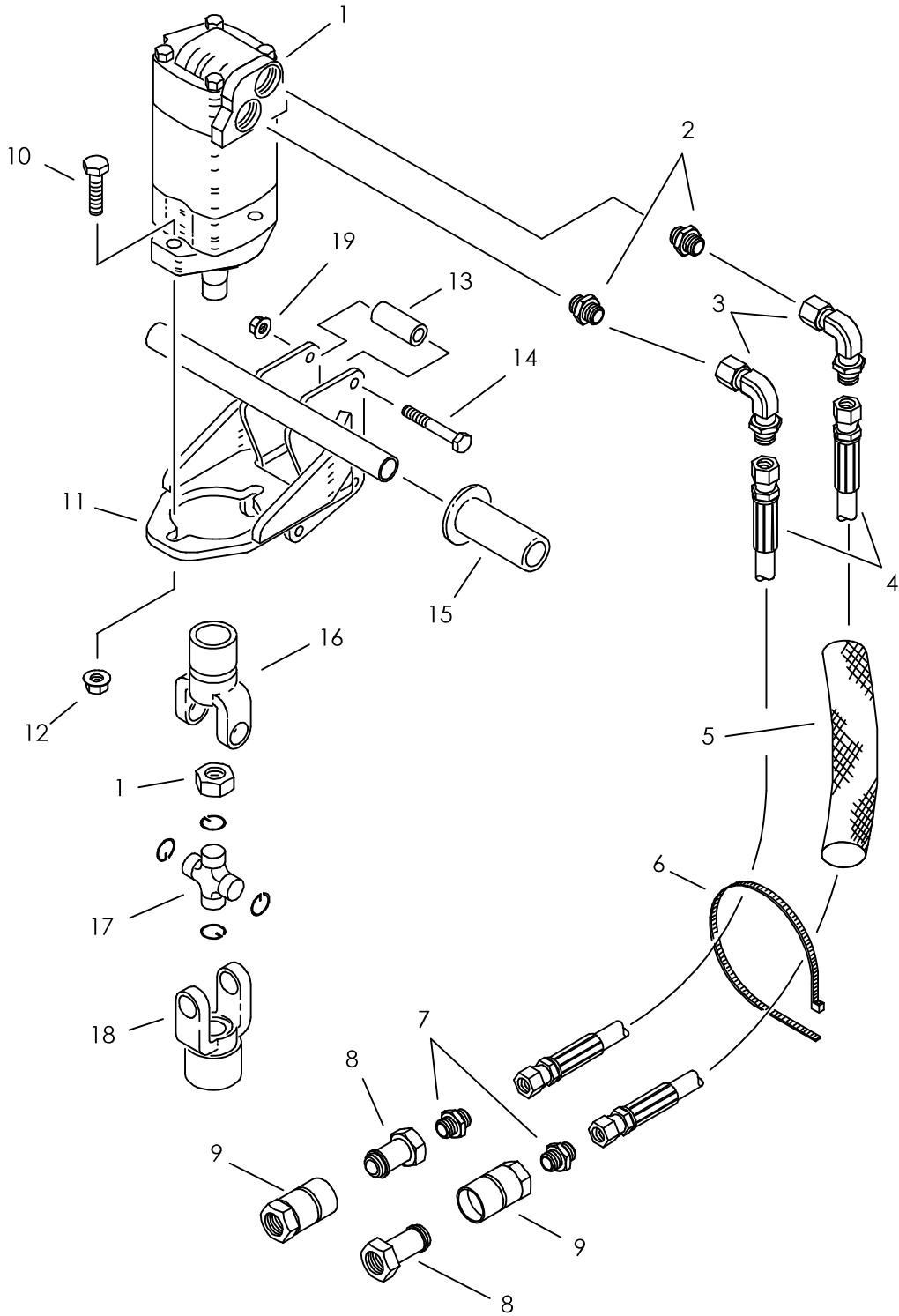

ANCHOR HYDRAULICS HEAVY DUTY ANCHOR SYSTEM

REF NO.	PART NUMBER	QTY	DESCRIPTION	REMARKS
1.	155-579	1	HYDRAULIC MOTOR	SEE FOOTNOTE I FOR SEAL KIT
2.	154-369	2	CONNECTOR (060-10S)	
3.	154-228	2	UNION (060-060FX90)	
4.	155-481	2	HOSE (060FX-185"-3000PSI)	
5.	115-900	1	ABRASION SLEEVE (2.54" X 190")	
6.	110-030	4	CABLE TIE (1/16" TO 4")	
7.	154-222	2	CONNECTOR (060-08S)	
8.	159-030	2	QDC ADAPTER (080-08SF)	
9.	159-029	2	QDC BODY (080-08SF)	
10.	106-477	2	SCREW (M12-1.75 X 45MM, 10.9)	
11.	355-759	1	MOTOR TROLLEY	
12.	106-354	2	FLANGE NUT (M12-1.75)	
13.	355-497	3	TROLLEY SPACER	
14.	106-332	3	SCREW (M10-1.5 X 70MM)	
15.	110-013	2	HANDLE GRIP (1", BLK)	
16.	182-092	1	YOKE (1-1/4", 5/16" KWY)	
17.	180-723	1	CROSS AND BEARING KIT (1.125")	
	115-010	1	ZERK (02N22.5)	OBSOLETE
	180-760	4	BEARING CAP (1-1/8")	
18.	180-813	1	YOKE (7/8" HEX)	
19.	106-266	3	FLANGE NUT (M10-1.50)	

NOT SHOWN:

FOOTNOTES:

I. USE SEAL KIT 500-347 FOR MOTOR VERSION 002, 003, 004 & 005. SEAL KIT 500-658 IS TO BE USED WITH VERSION 006 MOTORS.

NOTE:

HYDRAULIC MOTOR TAPERED KEYED SHAFT 1-1/4"

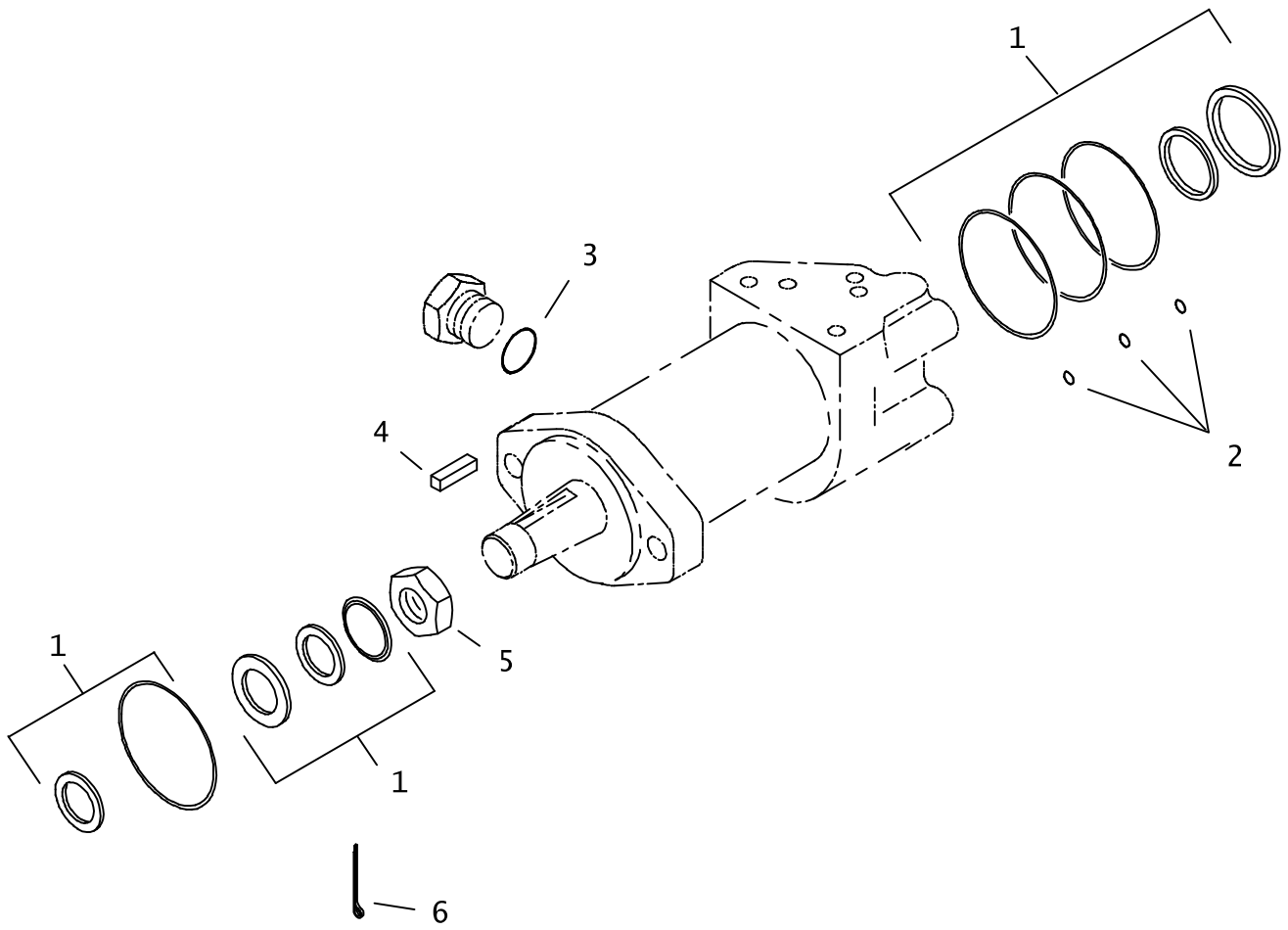

HYDRAULIC MOTOR TAPERED KEYED SHAFT 1-1/4"

REF NO.	PART NUMBER	QTY	DESCRIPTION	REMARKS
	155-579		HYDRAULIC MOTOR	INCL REF NO.'S 1 THRU 6, SEE FOOTNOTES 1 AND 4
	155-580		HYDRAULIC MOTOR	INCL REF NO.'S 1 THRU 5, SEE FOOTNOTES 2 AND 3
	153-280		HYDRAULIC MOTOR	INCL REF NO.'S 1 THRU 5, SEE FOOTNOTE 2
1.	500-347	1	SEAL REPAIR KIT	INCL REF NO.'S 2 AND 3, SEE FOOTNOTE 4
2.	155-771	3	O-RING (011 D70)	
3.	155-760	1	O-RING (904 D90)	
4.	165-915	1	KEY (5/16" X 1")	
5.	105-418	1	LOCKNUT (1-20 NEF)	
6.	105-501	1	COTTER PIN (1/8" X 2")	

NOT SHOWN:

FOOTNOTES:

1. USED ON ROTO WITCH II BORING UNITS.
2. USED ON ROTO WITCH III AND IV BORING UNITS.
3. SHAFT AND BEARING KIT- 500-1469
4. USE SEAL KIT 500-347 FOR MOTOR VERSION 002, 003, 004 & 005. SEAL KIT 500-658 IS TO BE USED WITH VERSION 006 MOTORS.

NOTE:

TRANSMITTER HOUSING

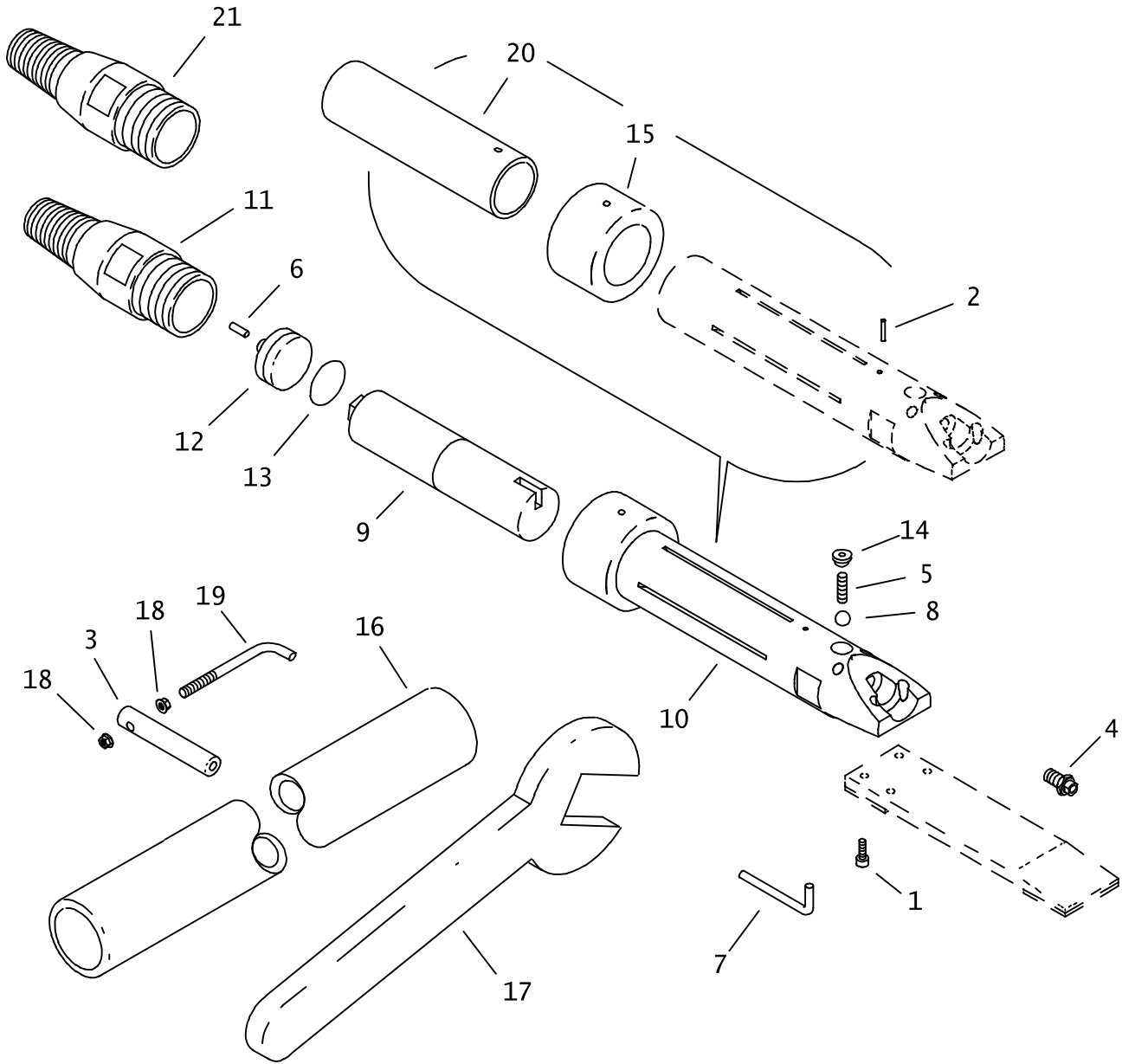

TRANSMITTER HOUSING

REF NO.	PART NUMBER	QTY	DESCRIPTION	REMARKS
	355-799		TRANSMITTER HOUSING ASSY	
	358-344		TRANSMITTER HOUSING ASSY	JT 2510 AND JT 2320
1.	106-323	1	BOLT 3/8-NC X 5/8" GD8)	SEE FOOTNOTE 1
2.	500-266	1	DOWEL PIN (1/8 X 1/2")	SEE FOOTNOTE 1
	105-554	1	DOWEL PIN (1/8 X 3/4")	SEE FOOTNOTE 3
3.	259-292	1	PLUG WRENCH	
4.	155-237	1	FLUID NOZZLE (03)	
	155-238	1	FLUID NOZZLE (04)	
	155-239	1	FLUID NOZZLE (05)	
	155-290	1	FLUID NOZZLE (06)	
5.	117-020	1	SPRING	
6.	106-121	1	STUD BOLT	
7.	259-198	1	HEX WRENCH	
8.	125-084	1	STAINLESS STEEL BALL	
9.	102-085	1	BEACON 83BR	
	102-016		BEACON 80B	SEE FOOTNOTE 2
	157-072		O-RING (025 D90)	
	220-155		BATTERY (5 PER PAC)	
10.	355-307	1	BEACON HOUSING 83BR	INCL REF NO.'S 2, 5, 8, 14, 15 & 20; SEE FOOTNOTE 1
	355-366	1	BEACON HOUSING 80B	INCL REF NO.'S 2, 5, 8, 14, 15 & 20
11.	355-330	1	END CAP	
12.	355-329	1	TRANSMITTER HOUSING PLUG	
13.	500-077	1	O-RING (127 D70)	
14.	155-074	1	PLUG	
15.	184-250	1	WEAR RING	
16.	259-300	1	CHEATER (60" LG)	SEE FOOTNOTE 1
17.	259-289	2	WRENCH	
18.	105-832	2	FLANGE LOCKNUT	
19.	259-291	1	BEACON WRENCH	
20.	354-213	1	BEACON HOUSING TUBE	
21.	358-311		DRILL PIPE END CAP	SEE FOOTNOTE 2

NOT SHOWN:

FOOTNOTES:

1. BEFORE ASSEMBLING THESE ITEMS USE CLEANER AND APPLY CLEANER AND APPLY LOCTITE 242 (OR EQUIVALENT). REFER TO OPERATOR'S MANUAL FOR COMPLETE ASSEMBLY INFORMATION.
2. S/N BEGINS WITH
3. USED WITH 80B BEACON

NOTE:

HYDRAULIC STAKE DRIVER

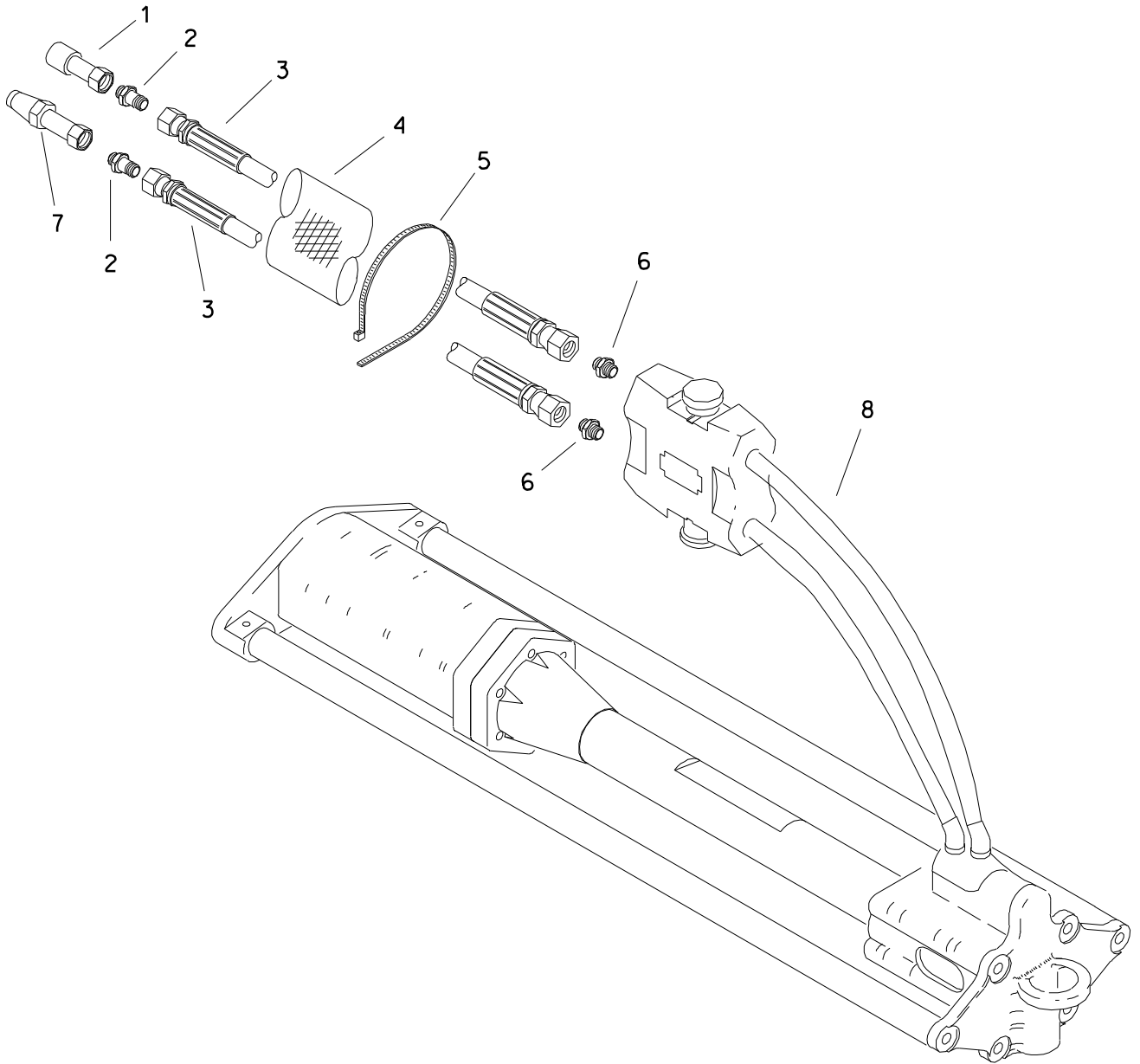

HYDRAULIC STAKE DRIVER

REF NO.	PART NUMBER	QTY	DESCRIPTION	REMARKS
	<u>100-965</u>		HYD STAKE DRIVER ASS'Y	SEE FOOTNOTE 1
1.	159-029	1	QDC BODY (08-08SF)	
2.	154-222	2	CONNECTOR (06D-08S)	
3.	155-481	2	HOSE (06DFX-185"-3000PSI)	
4.	115-900	1	ABRASION SLEEVE (2.54' X 190")	
5.	110-030	AR	CABLE TIE (1/16" TO 4")	
6.	514-077	2	CONNECTOR (06N-06D)	
7.	159-030	1	QDC ADAPTER (08-08SF)	
8.	355-268	1	HYDRAULIC STAKE DRIVER	
	500-716	-	SEAL REPAIR	

FOOTNOTES

NOT RECOMMENDED FOR USE WITH THE HOSE REEL.

NOTE

REFER TO O-RING CHART (800-301) IN BACK OF BOOK FOR REPLACEMENT OF SAE AND ORS O-RINGS.

ANCHORING PARTS

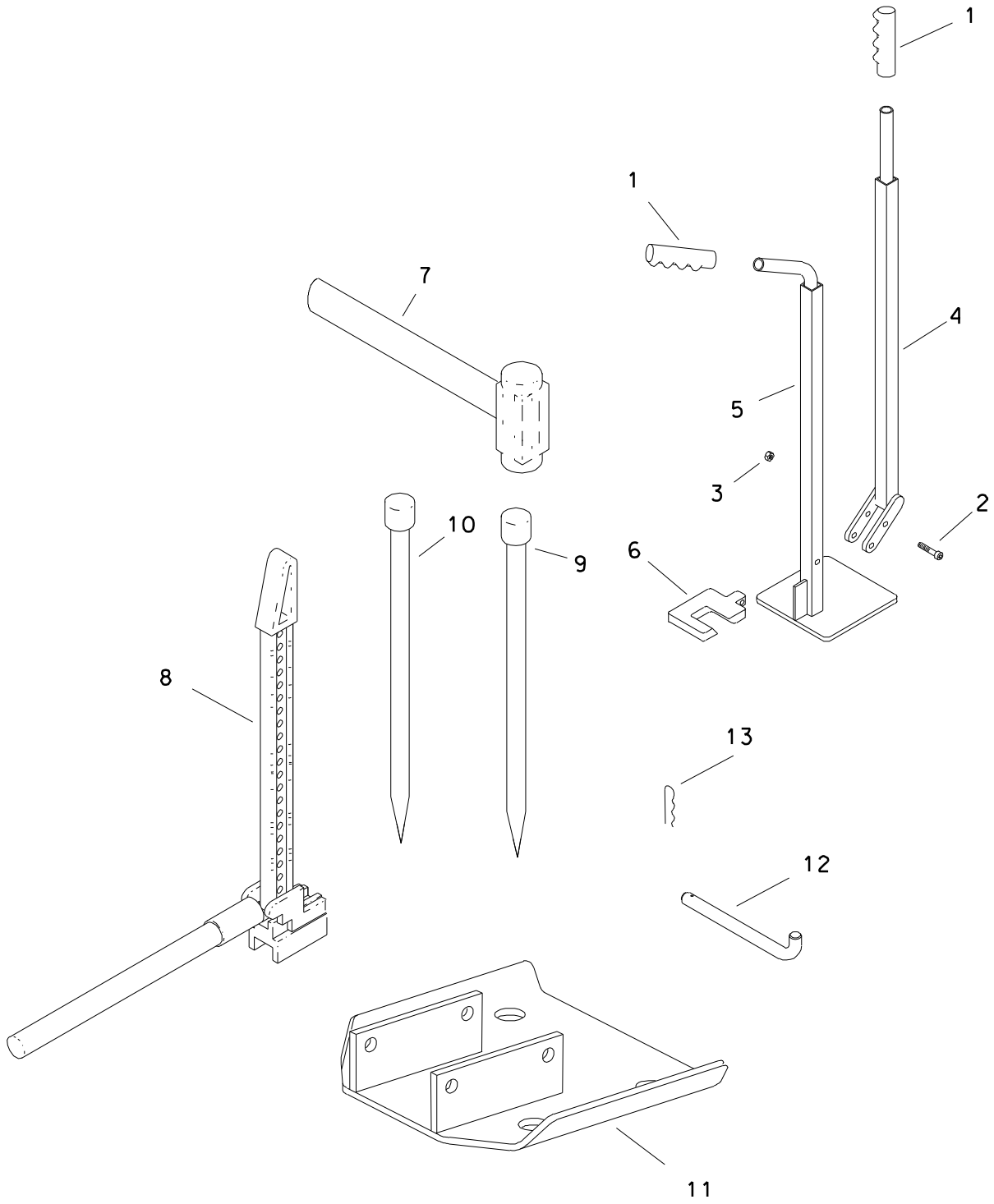

ANCHORING PARTS

REF NO.	PART NUMBER	QTY	DESCRIPTION	REMARKS
	355-654		STAKE JACK	INCL REF NO'S 1-6
1.	110-013	2	HAND GRIP (1", BLK)	
2.	105-880	2	SHOULDER BOLT (3/8" X 2", 5/16-NC)	
3.	105-089	2	LOCK NUT (5/16-NC)	
4.	355-656	1	LEVER	
5.	355-655	1	BASE	
6.	355-657	1	GRIP PLATE	
7.	259-084	1	SLEDGE HAMMER (12LBS)	
8.	355-145	1	HILO JACK PULLER-STAKE	STAKE
9.	355-367	6	STAKE	SEE FOOTNOTE 1
	355-188	6	STAKE (HYD DRIVER)	SEE FOOTNOTE 1
	355-189	1	STAKE	
	355-199	1	STAKE CAP	
	105-555	1	ROLL PIN (.375" X 2-1/2")	
	105-556	1	ROLL PIN (.219" X 2-1/2")	
10.	355-367	6	STAKE	SEE FOOTNOTE 2
	355-258	6	FRAME STAKE (1-1/2")	SEE FOOTNOTE 2
	355-189	1	STAKE	
	355-259	1	STAKE CAP	
	105-555	1	ROLL PIN (.375" X 2-1/2")	
	105-556	1	ROLL PIN (.219" X 2-1/2")	
11.	355-685	4	ANCHOR BRACKET	
12.	183-899	8	PIN	
13.	110-128	8	SPRING CLIP PIN (5/32" X 1")	

FOOTNOTES

1. USED WITH HYDRAULIC DRIVER
2. USED WHEN NOT USING HYDRAULIC DRIVER

2-POINT ANCHOR PARTS

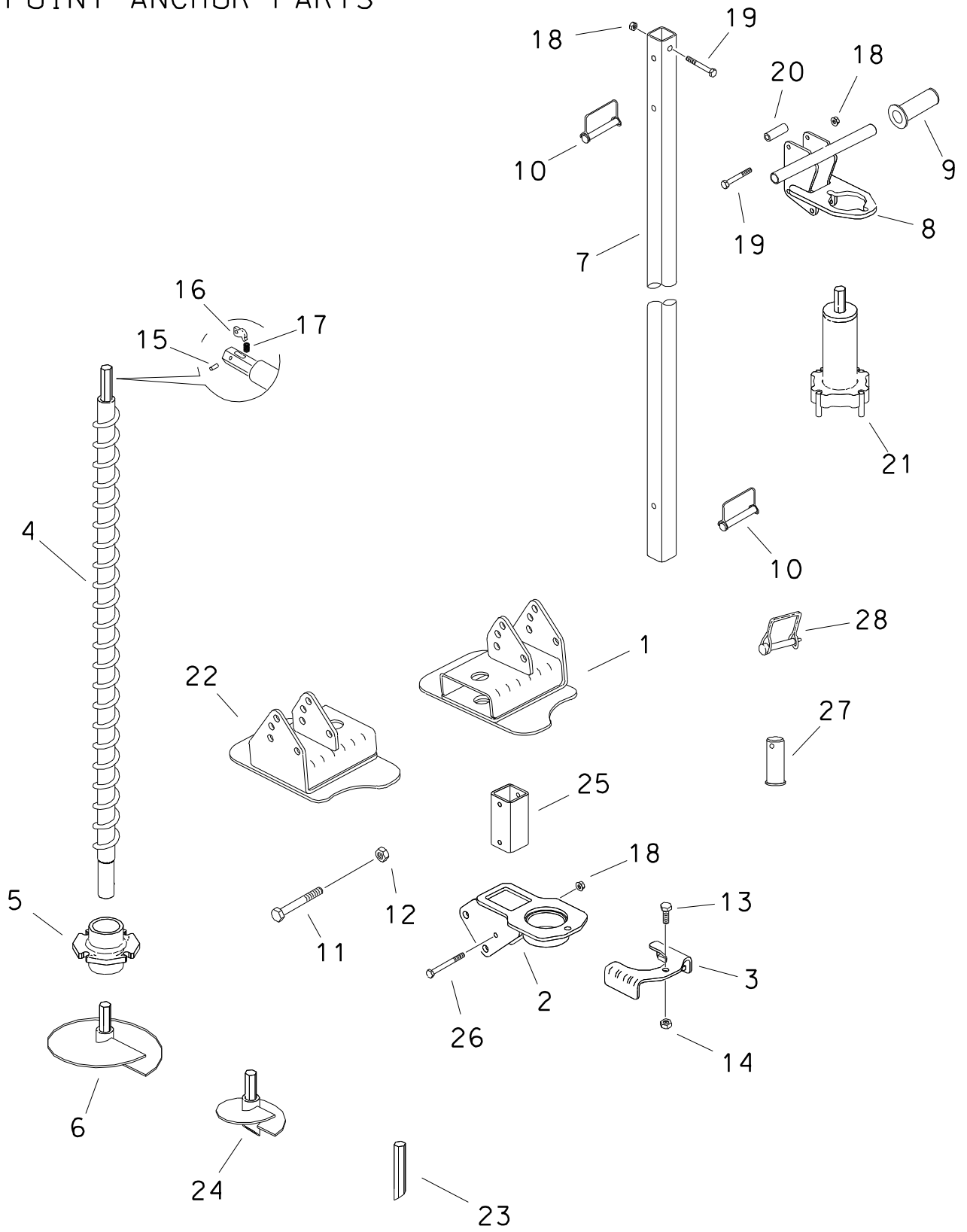

2-POINT ANCHOR PARTS

REF NO.	PART NUMBER	QTY	DESCRIPTION	REMARKS
1.	353-556	1	LT. ANCHOR PLATE	
2.	355-514	2	NUT HOUSING	
3.	355-503	2	NUT RETAINER	
4.	355-566	2	ANCHOR SHAFT	
5.	355-499	2	ANCHOR NUT	
6.	355-575	AR	AUGER (10")	OPTIONAL-INCL REF NO.'S 15, 16 AND 17
7.	355-498	1	TROLLEY RAIL	
8.	355-510	1	MOTOR TROLLEY	
9.	110-013	2	HAND GRIP (1", BLACK)	
10.	110-032	2	SNAPPER PIN (5/16" X 2-1/2")	
11.	106-540	4	SCREW (M16-2.00 X 130MM)	
12.	106-355	4	FLG NUT (M16-2.00, 10.9)	
13.	106-334	2	SCREW (M12-1.75 X 50MM)	
14.	106-089	2	NUT (M12-1.75, 10.9)	
15.	105-535	AR	ROLL PIN (1/8" X 5/8")	
16.	351-234	AR	COUPLING SEAR	
17.	115-618	AR	COMPRESSION SPRING (.625")	
18.	106-266	6	FLANGE NUT (M10-1.50)	
19.	106-332	4	SCREW (M10-1.5 X 70MM)	
20.	355-497	3	TROLLEY SPACER	
21.	355-505	1	NUT DRIVER	
22.	353-555	1	RT. ANCHOR PLATE	
23.	355-582	2	STAKE BIT	INCL REF NO.'S 15, 16 AND 17
24.	355-519	AR	AUGER (6")	OPTIONAL-INCL REF NO.'S 15, 16 AND 17
25.	355-515	2	TUBE SOCKET	
26.	106-564	2	SCREW (M10-1.50 X 100MM)	
27.	353-177	2	PIN	
28.	110-368	2	SNAPPER PIN (3/8 X 1-1/2")	

FOOTNOTES

4 POINT ANCHOR SYSTEM

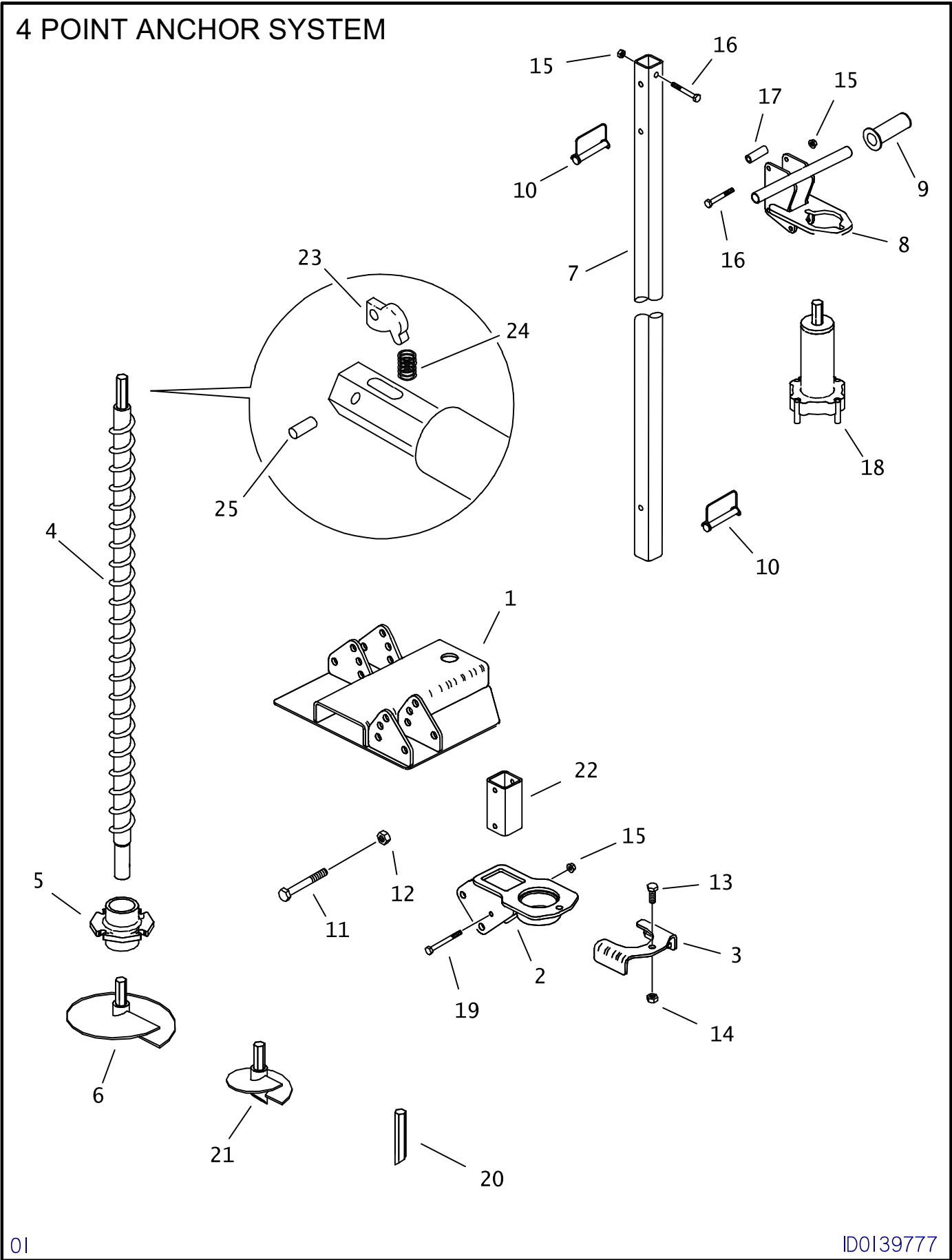

4 POINT ANCHOR SYTEM

REF NO.	PART NUMBER	QTY	DESCRIPTION	REMARKS
1.	355-597	2	DOUBLE ANCHOR BRACKET	
2.	355-514	4	NUT HOUSING	
3.	355-503	1	NUT RETAINER	
4.	355-566	4	ANCHOR SHAFT	
5.	355-499	4	ANCHOR NUT	
6.	355-575	AR	10" AUGER ASSEMBLY	
7.	355-498	1	TROLLEY RAIL TUBE	
8.	355-510	1	MOTOR TROLLEY	
9.	110-013	2	HANDLE GRIP	
10.	110-032	2	CLIP PIN (5/16" X 2-1/2")	
11.	106-540	8	SCREW (M16-2 X 130MM)	
12.	106-355	8	FLG NUT (M16-2.00)	
13.	106-334	1	SCREW (M12-1.75 X 50MM)	
14.	106-089	1	HEX NUT (M12-1.75)	
15.	106-266	8	FLG NUT (M10-1.5)	
16.	106-332	4	SCREW (M10-1.5 X 70MM)	
17.	355-497	3	TROLLEY SPACER	
18.	355-505	1	NUT DRIVER	
19.	106-564	4	SCREW (M10-1.5 X 100MM)	
20.	355-582	4	STAKE BIT (INCL. REF. NO'S 23, 24, AND 25)	
21.	355-519	AR	6" AUGER ASSEMBLY	
22.	355-515	4	TUBE SOCKET	
23.	351-234	AR	COUPLING SEAR	
24.	115-618	AR	COMPRESSION SPRING	
25.	105-535	AR	ROLL PIN (1/8 IN. X † IN.)	
	190-137	AR	SLIP-LATCH REPAIR KIT (INCL. REF. NO'S. 23, 24, AND 25)	

NOT SHOWN:

FOOTNOTES:

NOTE:

ANCHOR EXTENSION

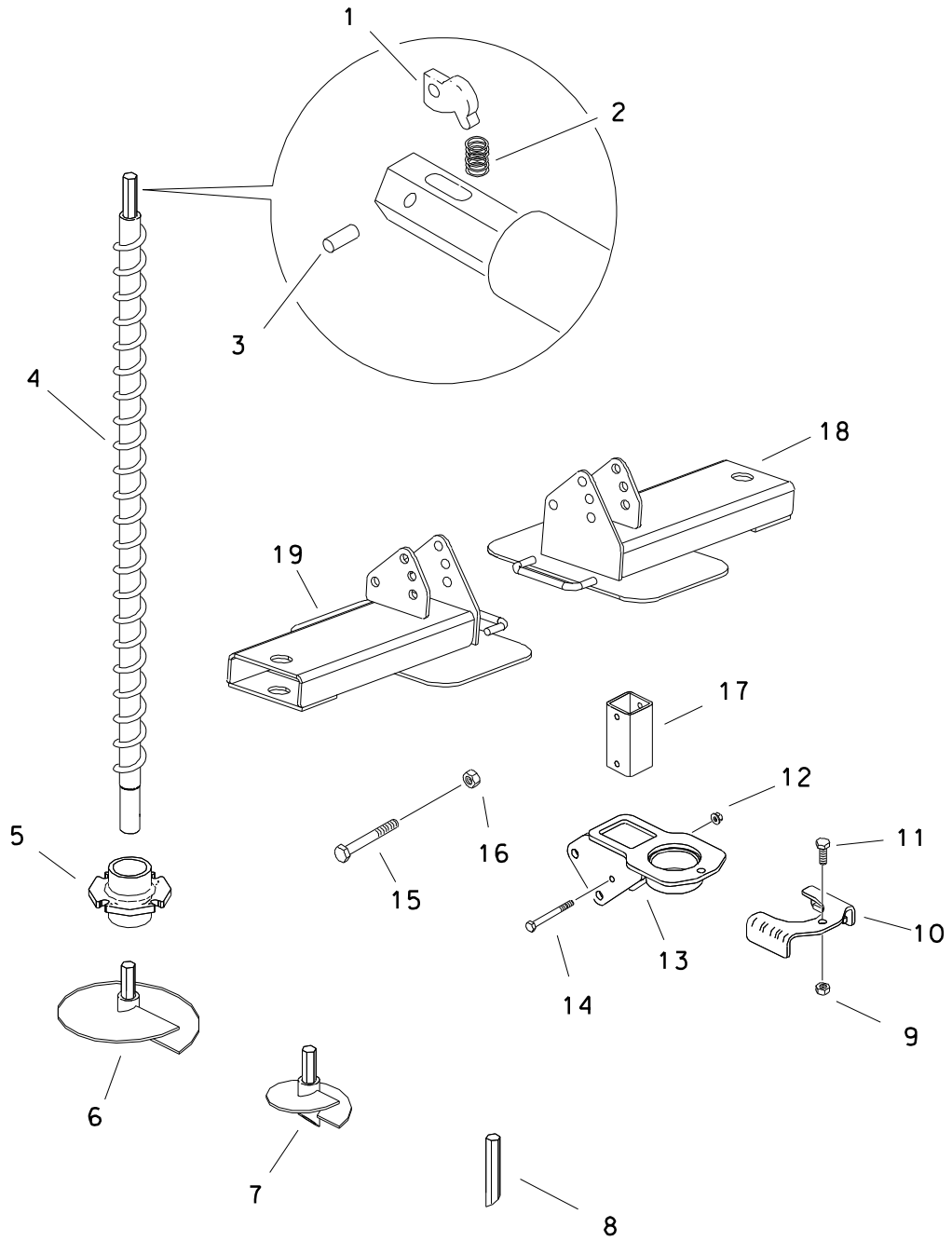

ANCHOR EXTENSION

REF NO.	PART NUMBER	QTY	DESCRIPTION	REMARKS
1.	351-234	AR	COUPLING SEAR	
2.	115-618	AR	COMPRESSION SPRING (.625")	
3.	105-535	AR	ROLL PIN (1/8" X 5/8")	
4.	355-566	4	ANCHOR SHAFT	
5.	355-499	4	ANCHOR NUT	
6.	355-575	AR	AUGER 10"	OPTIONAL - INCL REF NO.'S 15,16, AND 17
7.	355-519	AR	AUGER (6")	OPTIONAL - INCL REF NO.'S 15,16, AND 17
8.	355-582	4	STAKE BIT	INCL REF NO.'S 15,16, AND 17
9.	106-089	1	NUT (M12-1.75, 10.9)	
10.	355-503	1	NUT RETAINER ASS'Y	
11.	106-334	1	SCREW (M12-1.75 X 50MM)	
12.	106-266	8	FLG NUT (M10-1.50)	
13.	355-514	4	NUT HOUSING ASS'Y	
14.	106-564	4	SCREW (M10-1.5 X 100MM)	
15.	106-540	8	SCREW (M16-2 X 130MM)	
16.	106-355	8	FLG NUT (M16 X 2.00, 10.9)	
17.	355-515	4	TUBE SOCKET	
18.	353-234	2	LEFT ANCHOR	
19.	353-235	2	RIGHT ANCHOR	

FOOTNOTES

CURB STAKES

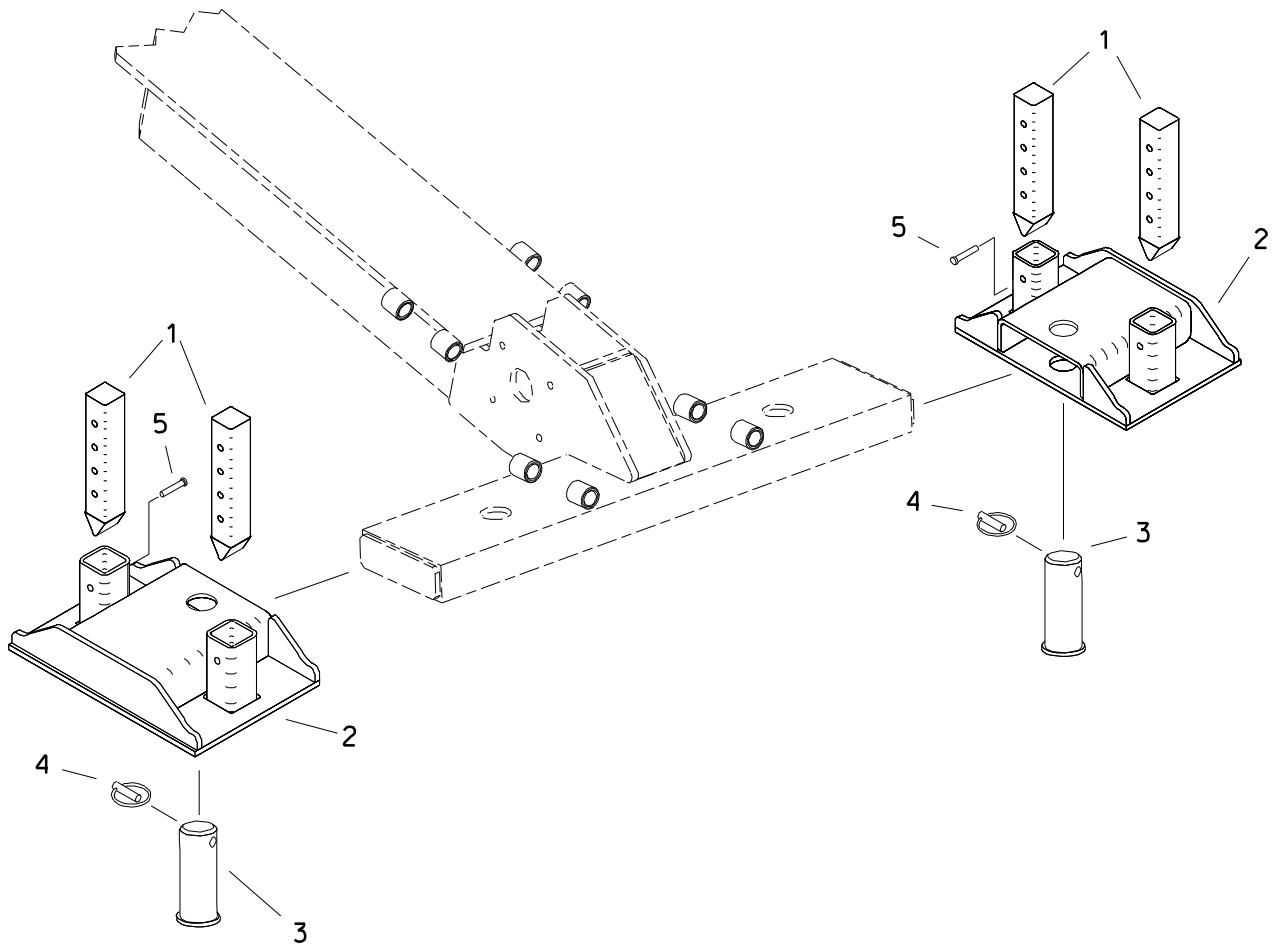

CURB STAKES

REF NO.	PART NUMBER	QTY	DESCRIPTION	REMARKS
1.	353-224	4	STAKE	
2.	353-223	2	STAKE PLATE	
3.	353-177	2	PIN	
4.	110-368	2	SNAPPER PIN (3/8" X 1-1/2")	
5.	110-833	4	SNAPPER PIN (3/8" X 2-3/4")	

FOOTNOTES

WATER TRANSFER SYSTEM

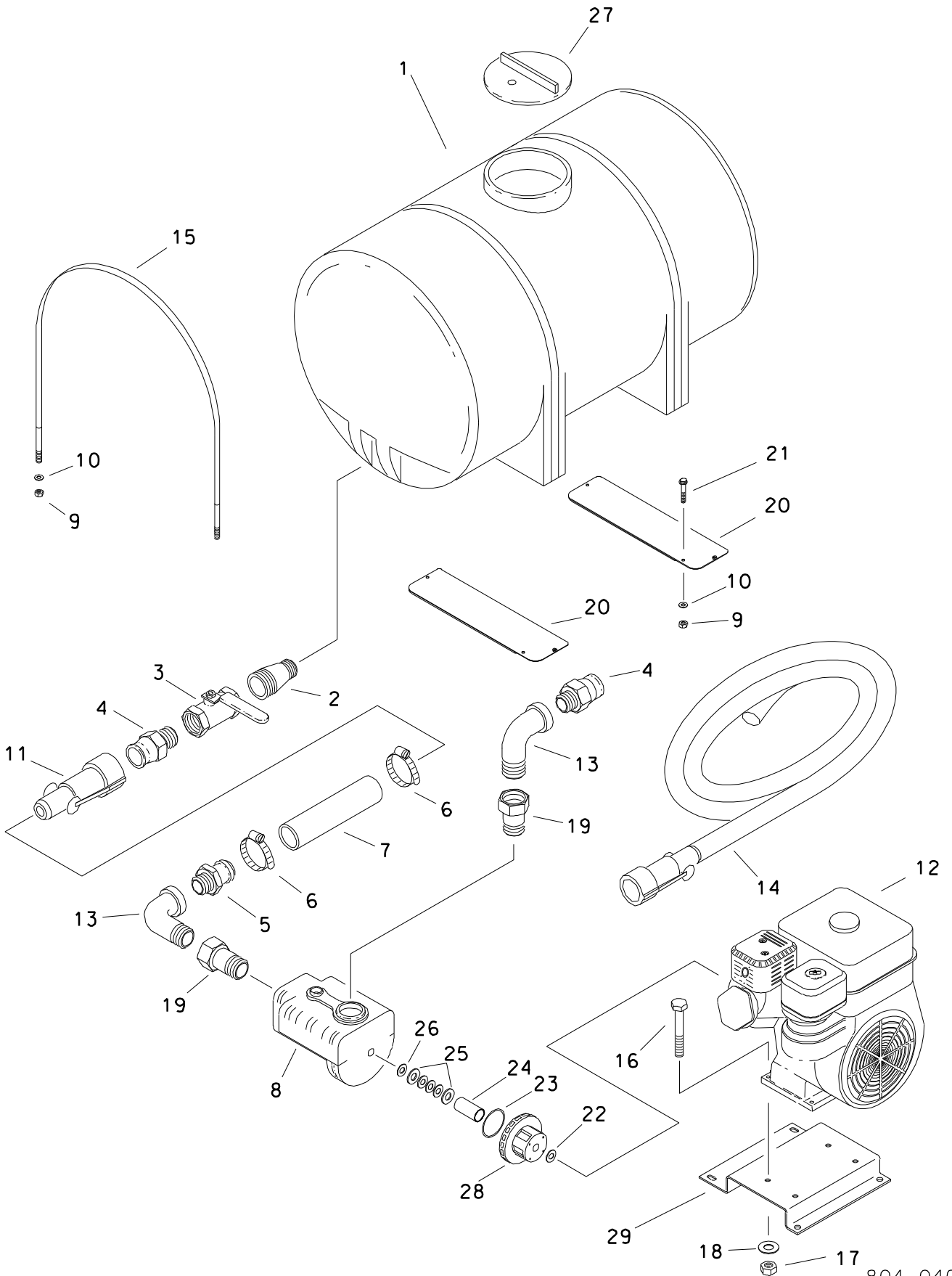

WATER TRANSFER SYSTEM

REF NO.	PART NUMBER	QTY	DESCRIPTION	REMARKS
	<u>100-956</u>		WATER TRANSFER SYSTEM	
1.	364-314	1	STORAGE TANK (325 GAL)	
	190-053		POLY-PATCH TANK REPAIR KIT	
2.	115-437	1	SWEDGE NIPPLE (32N-24N-6.5")	
3.	120-023	1	SHUT-OFF (24NF-24NF)	
4.	155-204	2	FHC ADAPTER (20-24N)	
5.	155-188	1	SLIP-ON COUPLER (24N-24H)	
6.	110-250	2	WORM CLAMP (1-1/4" TO 2-1/8")	
7.	116-782	AR	BULK HOSE (1-1/2", SOLD PER 1")	USE 1 @ 18"
8.	149-929	1	CENTRIFUGAL PUMP	INCL REF NO.'S 22 - 26
9.	105-065	4	LOCKNUT (1/2-NC)	
10.	105-071	4	WASHER (1/2")	
11.	155-205	1	FHC BODY (20-24H)	
	116-491		SQUARE RING (___ D70)	
12.	195-028	1	ENGINE-HONDA	
13.	115-044	2	STREET ELBOW (24N-24NF90)	
14.	154-440	1	HOSE (20FHC-300"-44)	
15.	365-374	2	TANK STRAP	
16.	105-130	4	BOLT (5/16-NC X 2-1/4")	
17.	105-089	4	LOCKNUT (5/16-NC)	
18.	105-117	4	WASHER (5/16")	
19.	115-087	2	REDUCER (32N-24NF)	
20.	<u>344-901</u>	2	BASE PLATE	
21.	105-067	2	BOLT (1/2-NC X 2-3/4")	
22.	500-860	1	SLINGER	
23.	500-248	1	O-RING (246 D70)	
24.	180-817	1	SLEEVE	
25.	191-017	1	PUMP SEAL KIT	
26.	165-834	1	SHIM (.015", IMPELLER)	
27.	364-434	1	TANK CAP (16", VENTED)	
28.	194-044	1	ENGINE ADAPTER	FOR HONDA & LOMBARDINI 5.5 HP ENGINES
29.	346-350	-	ENGINE MOUNT PLATE	NOT INCLUDED WITH SYSTEM

FOOTNOTES

DRILL PIPE ACCESSORIES

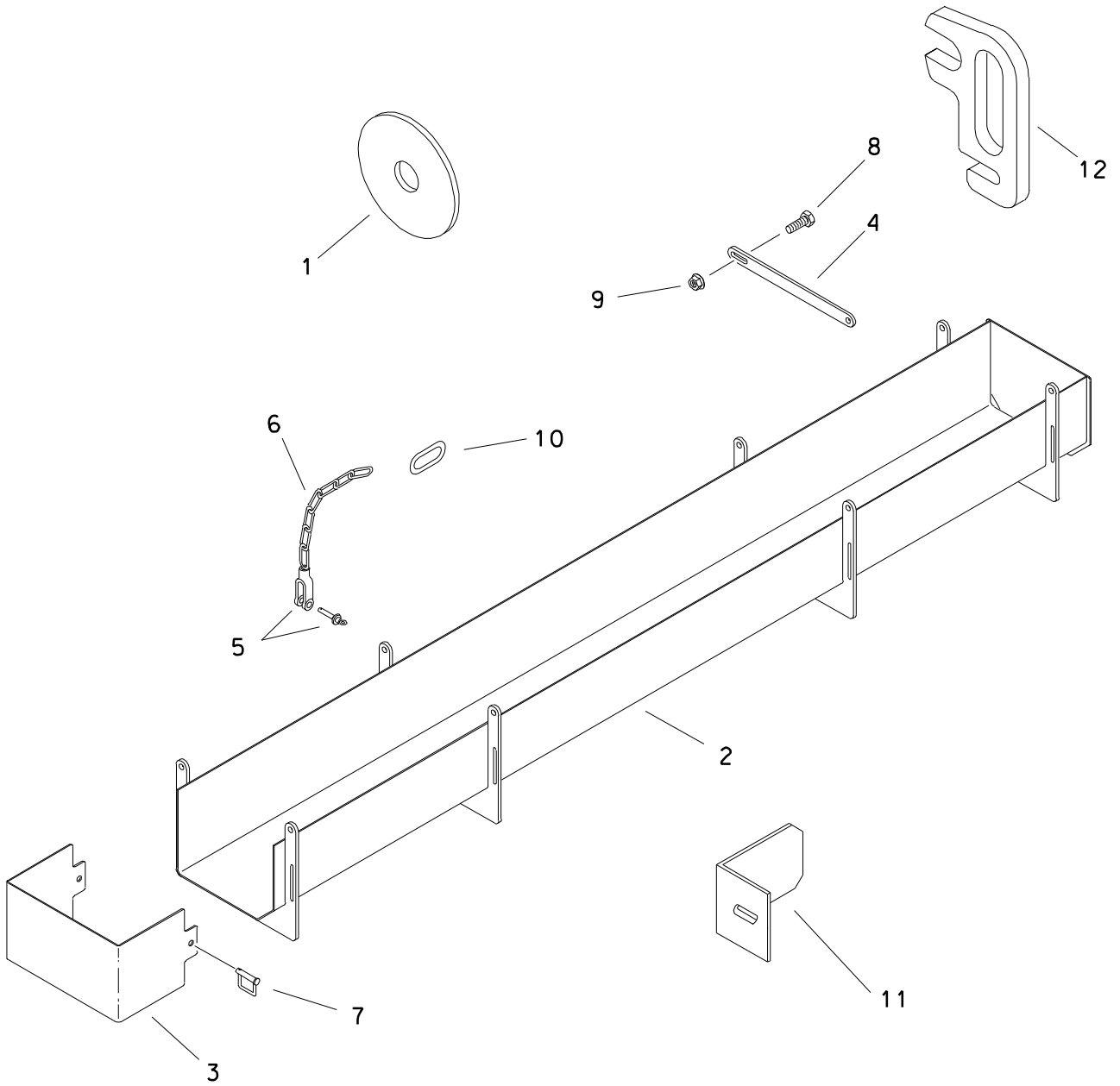

DRILL PIPE ACCESSORIES

REF NO.	PART NUMBER	QTY	DESCRIPTION	REMARKS
	353-167	AR	PIPE BOX	INCL REF NO.'S 2 THRU 11
1.	116-485	1	ROD WIPER	
2.	356-289	1	PIPE BOX	
3.	358-683	1	END COVER	
4.	358-684	2	LOCK BAR	
5.	110-289	6	ANCHOR SHACKLE (5/16")	
6.	110-161	4	CHAIN (5/0 X 32.4")	
7.	110-368	4	SNAPPER PIN (3/8" X 1-1/2")	
8.	105-031	2	BOLT (3/8-NC X 1")	
9.	105-047	2	LOCKNUT (3/8-NC)	
10.	110-516	2	MASTER OBLONG CHAIN LINK	
11.	356-288	4	ROD BOX SPACER	
12.	259-375	1	WRENCH	

FOOTNOTES

EZ-CONNECT

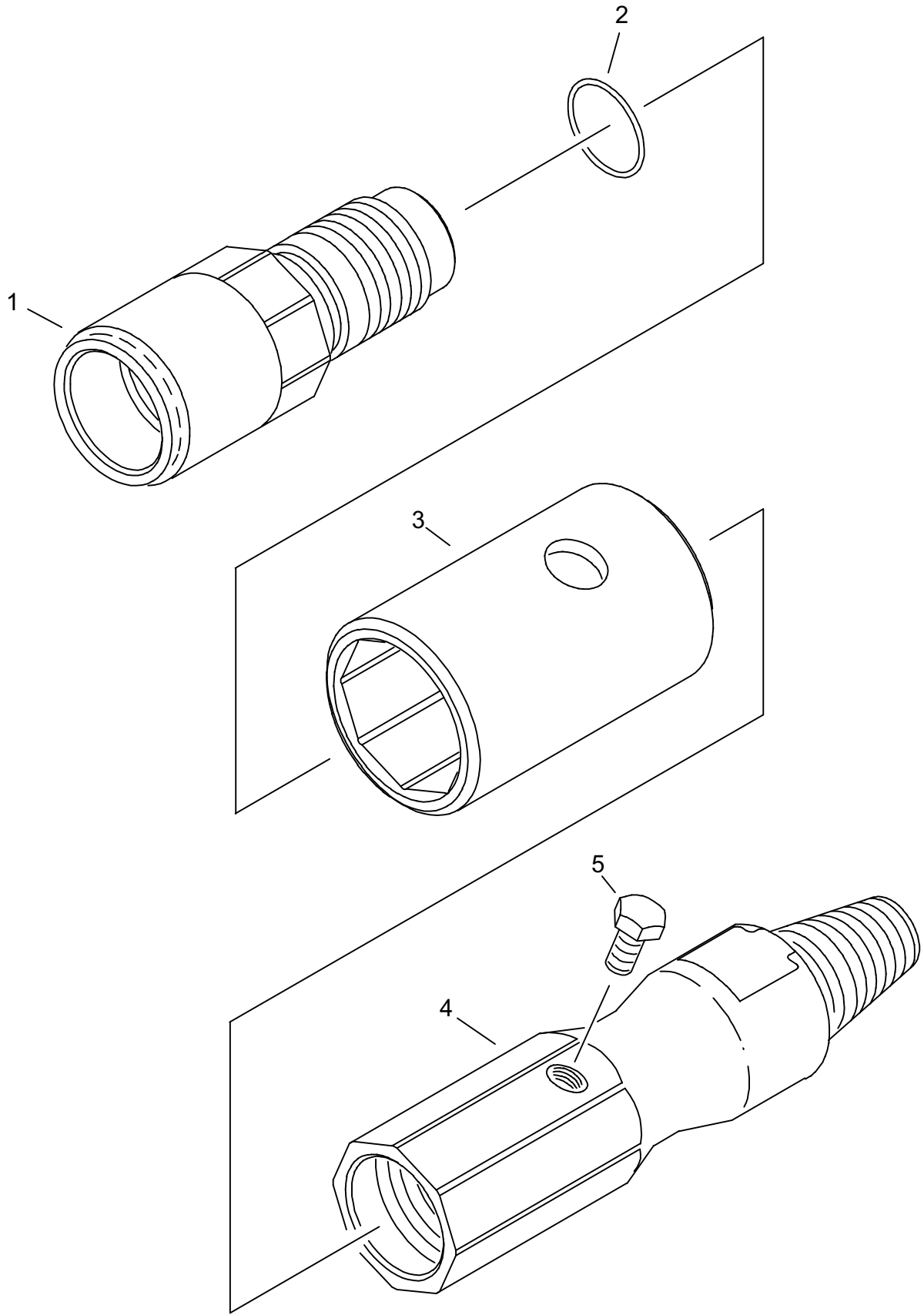

EZ-CONNECT

REF NO.	PART NUMBER	QTY	DESCRIPTION	REMARKS
	359-935		EZ-CONNECT ASS'Y (1.41-6, PT621)	SEE FOOTNOTES 1, 2 & 10 FITS PT620 & PT621
	359-934		EZ-CONNECT ASS'Y (1.41-6, JT440)	SEE FOOTNOTES 1, 3 & 10 FITS JT440A, JT910 & JT911
	344-557		EZ-CONNECT ASS'Y (1.41-6, JT920)	SEE FOOTNOTES 1, 4 & 10 FITS JT1210, JT820, PT1010 & JT920
	359-467		EZ-CONNECT ASS'Y (1.63-6)	SEE FOOTNOTES 1, 5 & 10 FITS JT2510, JT2511 & JT2320
	368-986		EZ-CONNECT ASS'Y (2610T 1.69-6)	SEE FOOTNOTES 1, 7 & 10 FITS JT1720 HD DRILL PIPE
	359-438		EZ-CONNECT ASS'Y (1.94-4)	SEE FOOTNOTES 1, 6 & 10 FITS JT3510, JT2520 & 860JT C THD PIPE
1.	344-555	2	EZ-CONNECT PIN (1.50-6 X 1.41-6)	
	359-462	2	EZ-CONNECT PIN (1.88-6 X 1.63-6)	
	368-334	2	EZ-CONNECT PIN (1.88-6 X 1.81-6)	
	359-468	2	EZ-CONNECT PIN (2.00-6 X 1.69-6)	
	359-433	2	EZ-CONNECT PIN (2.00-6 X 1.94-4)	
2.	157-193	2	O-RING (031 D90) POLYURETHANE	
	157-192	2	O-RING (028 D90) POLYURETHANE	
	157-194	2	O-RING (032 D90) POLYURETHANE	
3.	359-223	1	COLLAR (2.5")	
	359-466	1	COLLAR (3.0")	
	359-437	1	COLLAR (3.25")	
4.	344-556	1	EZ-CONNECT BOX (1.50-6 X 1.41-6)	
	344-587	1	EZ-CONNECT BOX (1.50-6 X 1.41-6)	
	344-588	1	EZ-CONNECT BOX (1.50-6 X 1.41-6)	
	359-463	1	EZ-CONNECT BOX (1.88-6 X 1.63-6)	
	368-335	1	EZ-CONNECT BOX (1.88-6 X 1.81-6)	
	368-987	1	EZ-CONNECT BOX (2.00-6 X 1.69-6)	
	359-434	1	EZ-CONNECT BOX (2.00-6 X 1.94-4)	
5.	105-181	1	BOLT (3/8-NC X 1/2 ")	SEE FOOTNOTE 10
	105-293	1	BOLT (1/2-NC X 3/4 ")	SEE FOOTNOTE 10

FOOTNOTES:

- LUBE THREADS & SHANK BEFORE ASSEMBLY AND EVERY BORE WITH TOOL JOINT COMPOUND.
- EZ-CONNECT ASS'Y (359-935) INCL'S: 2X 344-555 (EZ-CON. PIN), 2X 157-192 (O-RING), 1X 105-181 (SCREW), 1X 344-588 (EZ-CON. BOX), 1X 359-223 (COLLAR).
- EZ-CONNECT ASS'Y (359-934) INCL'S: 2X 344-555 (EZ-CON. PIN), 2X 157-192 (O-RING), 1X 105-181 (SCREW), 1X 344-587 (EZ-CON. BOX), 1X 359-223 (COLLAR).
- EZ-CONNECT ASS'Y (344-557) INCL'S: 2X 344-555 (EZ-CON. PIN), 2X 157-192 (O-RING), 1X 105-181 (SCREW), 1X 344-556 (EZ-CON. BOX), 1X 359-223 (COLLAR).
- EZ-CONNECT ASS'Y (359-467) INCL'S: 2X 359-462 (EZ-CON. PIN), 2X 157-193 (O-RING), 1X 105-293 (SCREW), 1X 359-463 (EZ-CON. BOX), 1X 359-466 (COLLAR).
- EZ-CONNECT ASS'Y (359-438) INCL'S: 2X 359-433 (EZ-CON. PIN), 2X 157-194 (O-RING), 1X 105-293 (SCREW), 1X 359-434 (EZ-CON. BOX), 1X 359-437 (COLLAR).
- EZ-CONNECT ASS'Y (368-986) INCL'S: 2X 359-468 (EZ-CON. PIN), 2X 157-194 (O-RING), 1X 105-293 (SCREW), 1X 368-987 (EZ-CON. BOX), 1X 359-437 (COLLAR).
- EARLY STYLES USE 106-808 (3/8-NC X ", LOW HD ALN).
- EARLY STYLES USE 106-811 (1/2-NC X 1", LOW HD ALN).
- BEFORE INSTALLATION OF RETAINING BOLTS (105-181 & 105-293), APPLY ANTI-SEIZE TO THE THREADS.

NOTE:

ALL EZ-CONNECT ASSEMBLIES INCLUDE REFERENCE NUMBERS 1 THRU 5.

WASH WAND

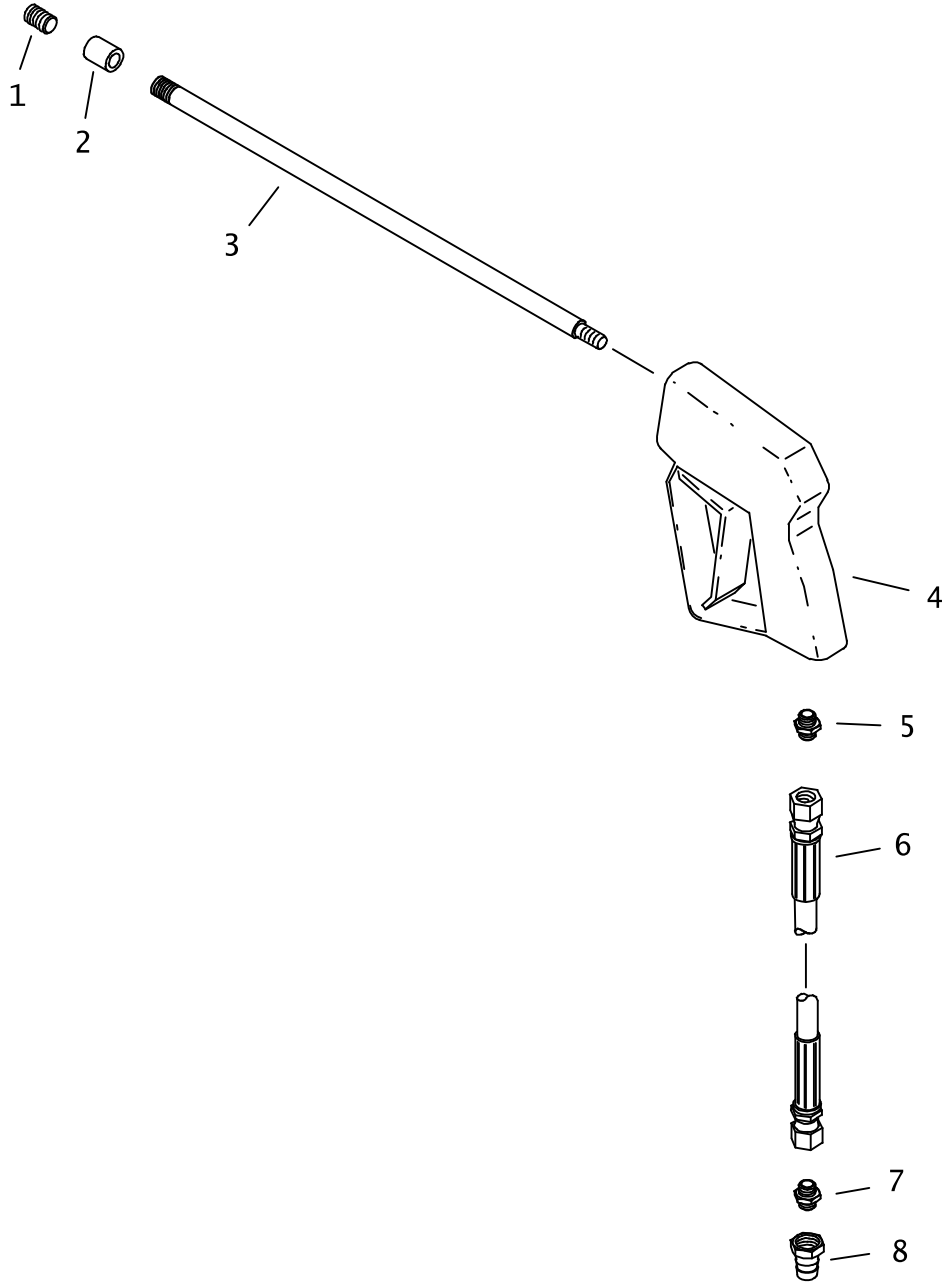

WASH WAND

REF NO.	PART NUMBER	QTY	DESCRIPTION	REMARKS
	259-374		WATER SPRAY GUN (PARTS ASS'Y)	INCL REF NO.'S 1 THRU 8
1.	155-242	1	NOZZLE (04N, ORF. 047", TC)	
2.	115-170	1	COLLAR (04NF)	
3.	259-353	1	WASH WAND (04N-36")	
4.	259-197	1	SPRAY GUN	
	190-179	1	SEAL REPAIR KIT	
5.	514-141	1	CONNECTOR (06N-080)	
6.	154-804	1	HOSE (080FX-290"-3000)	
7.	154-233	1	CONNECTOR (08S-080)	
8.	159-089	1	QDC ADAPTER (08-08SF)	
	190-186	1	SEAL REPAIR KIT	

NOT SHOWN:

FOOTNOTES:

NOTE:

REFER TO O-RING CHART (800-301) IN BACK OF THE BOOK FOR REPLACEMENT OF O-RINGS.

FLUID MIXING ACCESSORIES

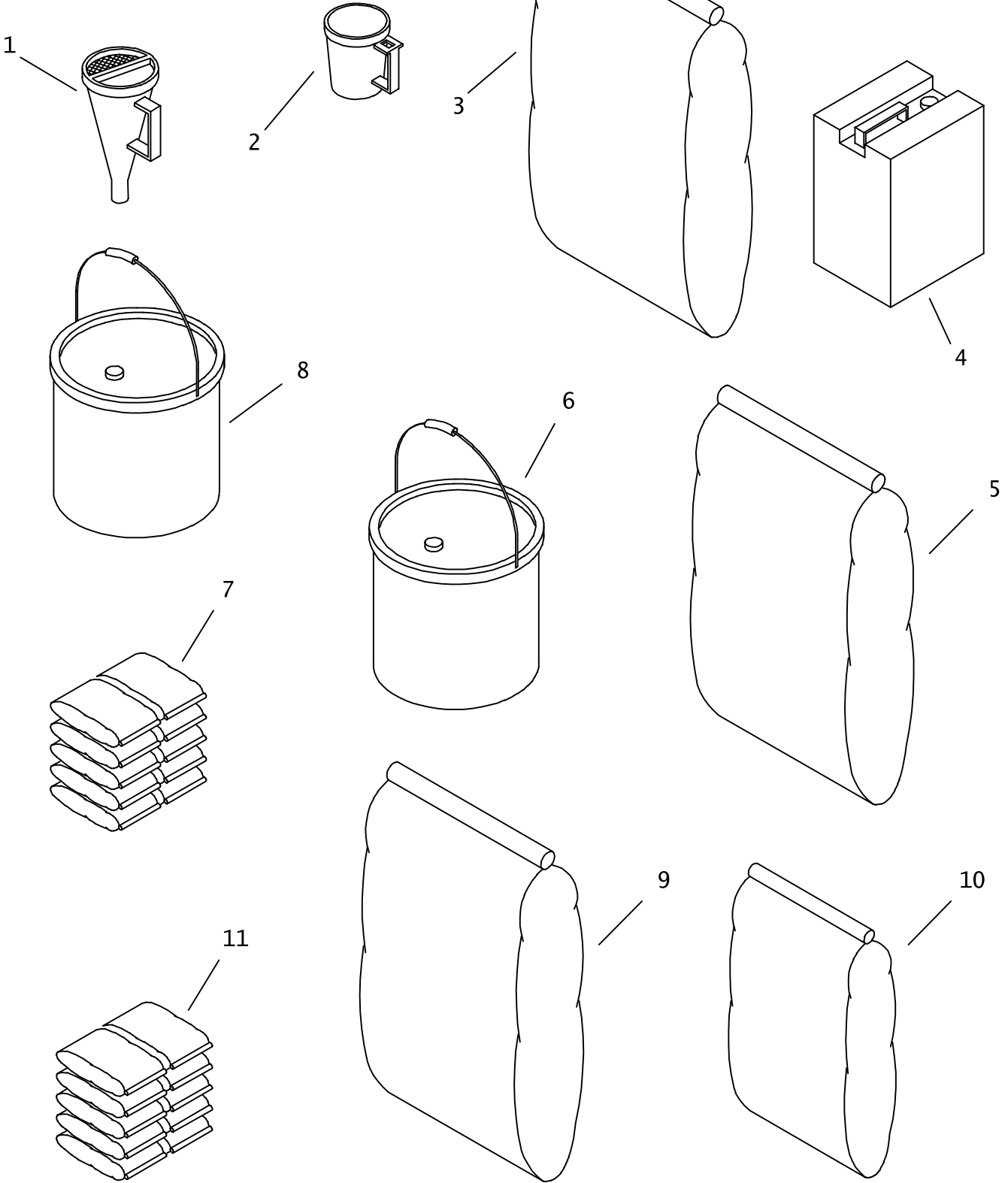

FLUID MIXING ACCESSORIES

REF NO.	PART NUMBER	QTY	DESCRIPTION	REMARKS
1.	259-195	1	VISCOSITY FUNNEL	
2.	259-196	1	VISCOSITY CUP	
3.	259-804	AR	BENTONITE, QUIK-GEL (50 LB)	
4.	259-805	AR	LIQUID POLYMER, EZ-MUD (5 GAL)	
5.	259-807	AR	BENTONITE, BORE-GEL (50 LB)	
6.	259-808	AR	VISCOSIFIER, LIQUI-TROL (5 GAL)	
7.	259-809	AR	POWDER POLYMER, QUIK-TROL (20 LB)	
8.	259-810	AR	WET AGENT, CON-DET (5 GAL)	
9.	259-821	AR	'PAC-R' FILTRATION CONTROL	
10.	259-822	AR	'BARAZAN D+' VISCOSIFIER	
11.	259-832	AR	'NO SAG' (20# BOX/10-2#BAGS)	

NOT SHOWN:

191-158	1	DRILLING FLUID TEST KIT
259-487	1	SHEAROMETER

FOOTNOTES:

NOTE:

WORKING LIGHT

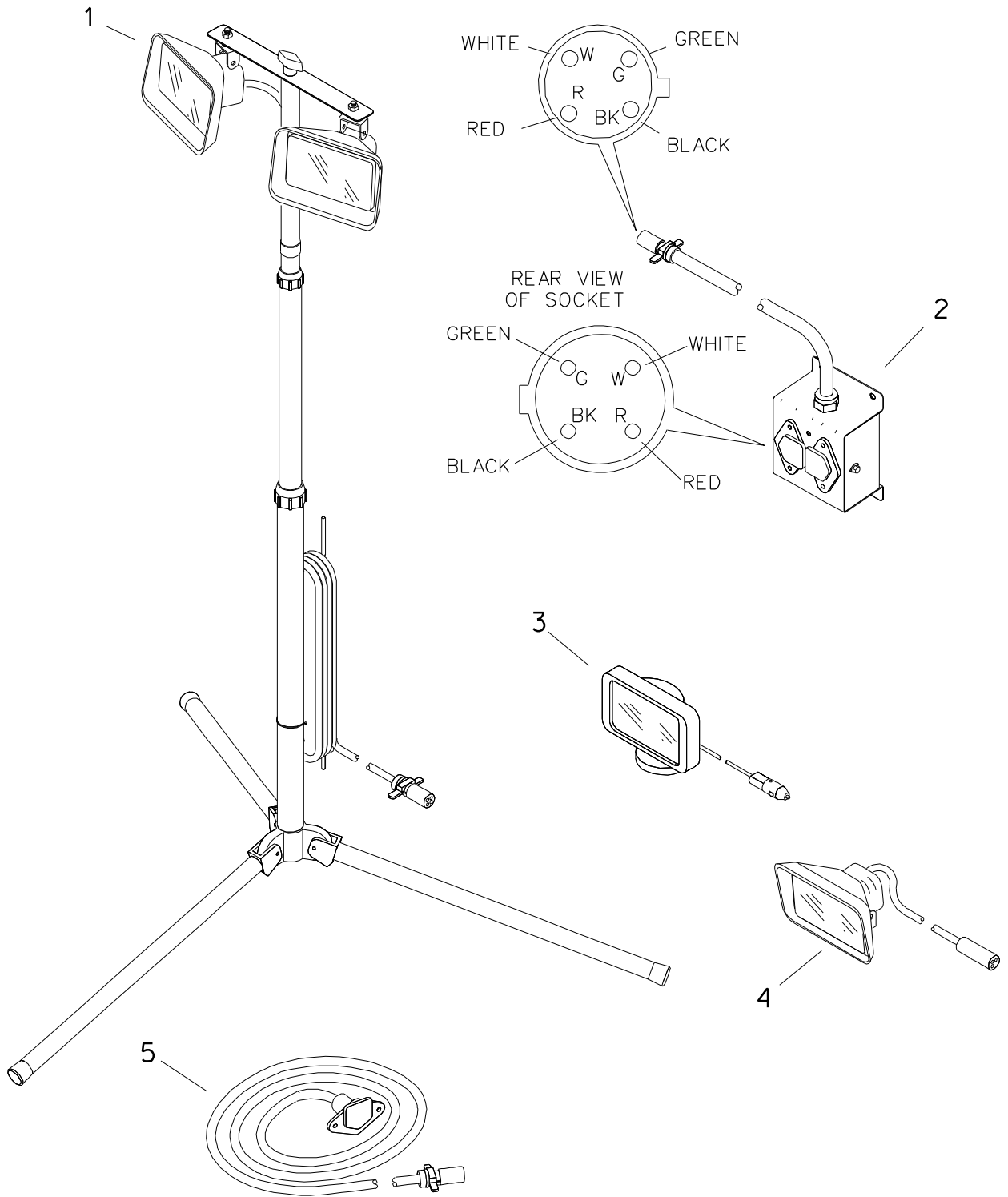

WORKING LIGHT

REF NO.	PART NUMBER	QTY	DESCRIPTION	REMARKS
1.	190-663	1	WORKING LIGHT CONVERSION KIT	INCL TRIPOD
	217-084	-	TRIPOD	
	217-094	1	DUAL LIGHT CABLE	
	217-080	2	WORKING LAMP (12V DC)	RECTANGULAR, MULTI-PURPOSE
	214-228	2	LIQUID-TIGHT FITTING	
	106-176	2	CONDUIT LOCKNUT (Ø8N)	
	110-373	1	BOLT-ON CLAMP (13/16")	
	106-162	1	FLG SCREW (M8-1.25 X 20mm)	
	106-386	1	FLG LOCKNUT (M8-1.25)	
	347-832	1	BRACKET (LIGHT KIT)	
	110-030	1	CABLE TIE (1/16" TO 4")	
	110-259	1	BOLT-ON CLAMP (.625")	
2.	190-664	1	LIGHT BOX KIT	
	347-833	1	LIGHT JUNCTION BOX	
	347-836	1	BACK PLATE	
	214-229	1	LIGHT HARNESS	JUNCTION BOX
	217-040	3	CONNECTOR (4-WAY, FM)	
	217-039	1	INDICATOR LIGHT (RED)	
	106-379	10	FLG LK SCREW (M6-1.00 X 20mm)	
	106-106	6	NUT (M6-1.00)	
	106-754	4	WELD NUT (M10-1.50)	
3.	217-098	1	WORK LAMP {12V DC, MAGNETIC}	
4.	190-665	1	LIGHT KIT (SINGLE)	
	217-080	1	WORKING LAMP (12V DC)	RECTANGULAR, MULTI-PURPOSE
	217-092	1	SINGLE LIGHT CABLE	
	214-228	1	LIQUID-TIGHT FITTING	
	106-176	1	CONDUIT LOCKNUT (Ø8N)	
5.	217-095	1	EXTENSION CABLE (15 M)	50 FT
	217-096	1	EXTENSION CABLE (30M {100'})	

FOOTNOTES

SOIL SAMPLER

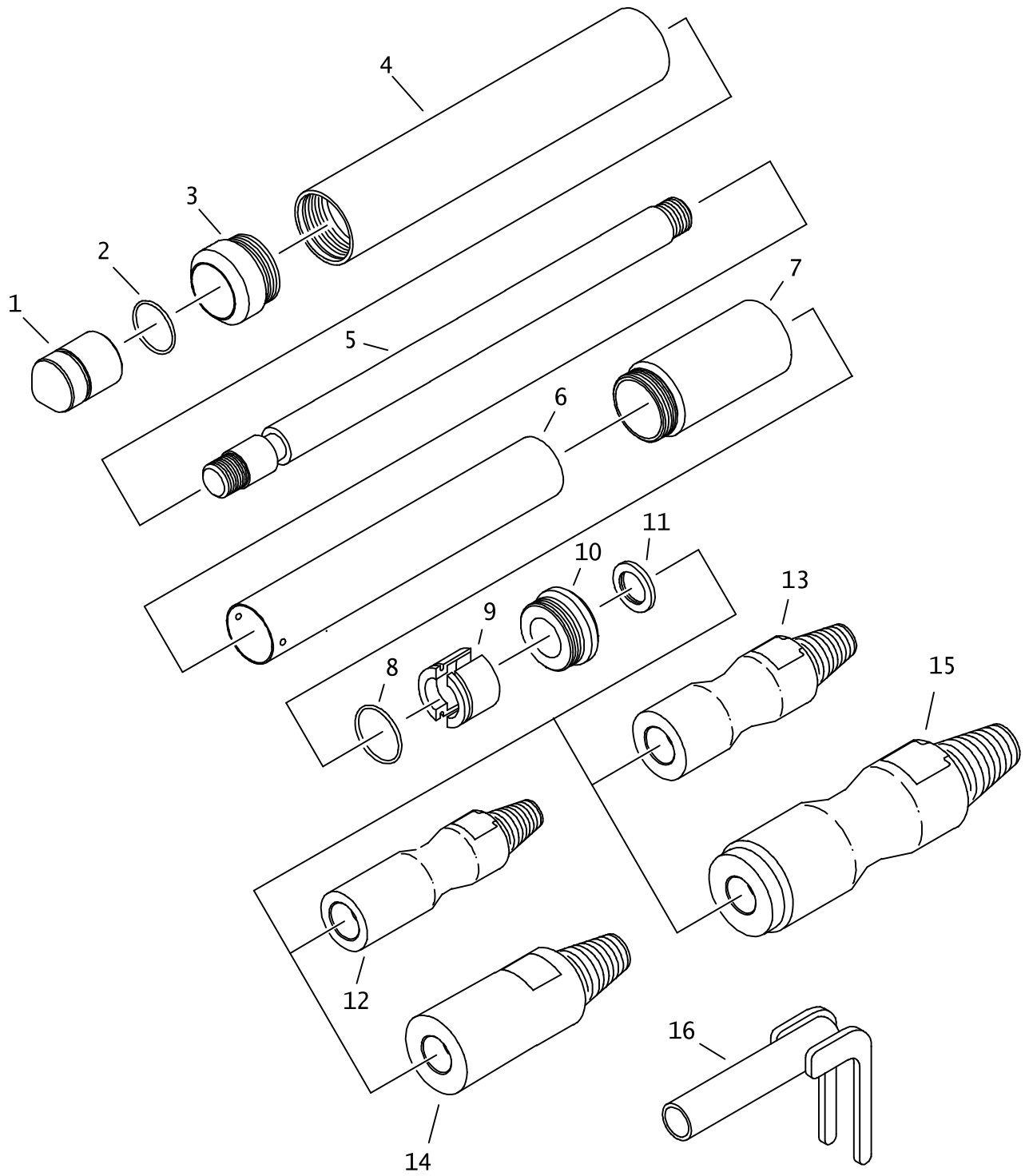

SOIL SAMPLER

REF NO.	PART NUMBER	QTY	DESCRIPTION	REMARKS
	359-696		SOIL SAMPLER (440)	INCL REF NO.'S 1 THRU 12 AND 16
	359-697		SOIL SAMPLER (25/23)	INCL REF NO.'S 1 THRU 11, 13 AND 16
	359-698		SOIL SAMPLER (860)	INCL REF NO.'S 1 THRU 11, 14 AND 16
	359-699		SOIL SAMPLER (3510)	INCL REF NO.'S 1 THRU 11, 15 AND 16
1.	356-218	1	NOSE CONE	
2.	155-730	1	O-RING (129 D70)	
3.	356-214	1	NOSE CONE GUIDE	
4.	356-216	1	MISSILE BODY	
5.	356-217	1	PUSH SHAFT	
6.	356-222	1	SPECIMAN TUBE	
7.	356-219	1	STAGE TWO	
8.	155-794	1	O-RING (124 D70)	
9.	356-221	1	LOCK	
10.	356-220	1	TAILPIECE	
11.	155-880	1	INTERNAL SEAL	
12.	359-668	1	440 SOIL SAMPLER ADAPTER	
13.	359-669	1	25/23 SOIL SAMPLER ADAPTER	
14.	359-670	1	860 SOIL SAMPLER ADAPTER	
15.	359-671	1	3510 SOIL SAMPLER ADAPTER	
16.	359-692	1	SPREADER	

NOT SHOWN:

FOOTNOTES:

NOTE:

NOTES:

MISCELLANEOUS

SAE Bolt and Nut Torque Value Chart

Grade 5: UNC or UNF Thread

Size	Hex nut, or bolt tapped into hex nut, or d&t hole		Hex top deformed locknut		Flange nut, locknut, or bolt tapped into flange nut or d&t* hole	
	ft•lb	N•m	ft•lb	N•m	ft•lb	N•m
1/4	12	16	8	11	20	27
5/16	25	34	15	20	45	60
3/8	40	54	25	34	75	100
7/16	65	90	40	55	125	170
1/2	100	135	60	80	190	260
9/16	150	200	90	125	270	370
5/8	200	270	120	165	370	500
3/4	350	475	210	285	650	880
7/8	560	760	340	460	1250	1425
1	840	1140	500	680	1580	2145
1-1/8	1030	1400	320	840	1950	3645
1-1/4	1460	1980	880	1195	2760	3475

Grade 8: UNC or UNF Thread

Size	Hex nut, or bolt tapped into hex nut, or d&t hole		Hex top deformed locknut		Flange nut, locknut, or bolt tapped into flange nut or d&t* hole	
	ft•lb	N•m	ft•lb	N•m	ft•lb	N•m
1/4	14	19	10	14	24	33
5/16	30	40	18	25	50	70
3/8	55	73	35	50	90	125
7/16	85	115	50	70	140	190
1/2	130	175	80	110	220	300
9/16	190	260	110	150	310	420
5/8	260	355	160	245	430	585
3/4	450	610	270	365	750	1015
7/8	730	990	440	600	1210	1640
1	1090	1480	650	880	1320	2465
1-1/8	1550	2100	930	1260	2580	3500
1-1/4	2180	2955	1310	1780	3640	4935

*drilled and tapped

Metric Bolt and Cap Screw Torque Values

Size	Class 4.8				Class 8.8 and 9.8				Class 10.9				Class 12.9			
	Lubricated		Dry		Lubricated		Dry		Lubricated		Dry		Lubricated		Dry	
	N•m	ft•lb	N•m	ft•lb	N•m	ft•lb	N•m	ft•lb	N•m	ft•lb	N•m	ft•lb	N•m	ft•lb	N•m	ft•lb
M6	4.8	3.5	6	4.5	9	6.5	11	8.5	13	9.5	17	12	15	11.5	19	14.5
M8	12	8.5	15	11	22	16	28	20	32	24	40	30	37	28	47	35
M10	23	17	29	21	43	32	55	40	63	47	80	60	75	55	95	70
M12	40	29	50	37	75	55	95	70	110	80	140	105	130	95	165	120
M14	63	47	80	60	120	88	150	110	175	130	225	165	205	150	260	190
M16	100	73	125	92	190	140	240	175	275	200	350	225	320	240	400	300
M18	135	100	175	125	260	195	330	250	375	275	475	350	440	325	560	410
M20	190	140	240	180	375	275	475	350	530	400	675	500	625	460	800	580
M22	260	190	330	250	510	375	650	475	725	540	925	675	850	625	1075	800
M24	330	250	425	310	650	475	825	600	925	675	1150	850	1075	800	1350	1000
M27	490	360	625	450	950	700	1200	875	1350	1000	1700	1250	1600	1150	2000	1500
M30	675	490	850	625	1600	950	1650	1200	1850	1350	2300	1700	2150	1600	2700	2000
M33	900	675	1150	850	1750	1300	2200	1650	2500	1850	3150	2350	2900	2150	3700	2750
M36	1150	850	1450	1075	2250	1650	2850	2100	3200	2350	4050	3000	3750	2750	4750	3500

Do not use these values if a different torque value or tightening procedure is given for specific application. Torque values listed are for general use only. Check tightness of fasteners periodically.

Shear bolts are designed to fail under predetermined loads. Always replace shear bolts with identical property class fasteners.

Fasteners should be replaced with the same or higher property class. If higher property class fasteners are used, these should only be tightened to strength of original.

Make sure fastener threads are clean and that the threads are properly started. This will prevent them from cross threading or galling when tightened.

Tighten plastic insert or crimped type steel locknuts to approximately 50% of dry torque indicated on chart. Apply torque to the nut - not the bolt head. Tighten toothed or serrated type locknuts to full torque value.

LUBRICATED means coated with lubricant. DRY means plain or zinc plated without any type of lubricant.

Hydraulic Cylinder Bolt Torque Chart

Bolt Size (inch)	Bolt Part No.	Cylinder Repair Kit Part No.	Torque (ft•lb)	Torque (N•m)
1/2	106-096	190-165	90-100	120-135
5/8	106-097	190-166 & 190-169	180-200	245-270
3/4	106-098	190-167 & 190-170	290-325	395-440
7/8	106-122	190-172 & 190-174	410-640	550-625
1	106-145	190-175 & 190-189	630-700	855-950
1-1/8	106-146	190-177	770-850	1045-1170

As a general rule:

- 1/2-inch bolts are used in cylinders with 1-inch rods
- 5/8-inch bolts are used in cylinders with 1 1/4-inch rods
- 3/4-inch bolts are used in cylinders with 1 1/2-inch rods
- 7/8-inch bolts are used in cylinders with 1 3/4-inch rods
- 1-inch bolts are used in cylinders with 2-inch rods (one with 1 3/4-inch)
- 1-1/8-inch bolts are used in cylinders with 2-1/4-inch rods

IMPORTANT: Do not reuse cylinder piston bolts when rebuilding a hydraulic cylinder. Each cylinder repair kit contains a new bolt. Use it. Lubricate lightly and torque to value shown on chart.

SAE & ORS Hydraulic Fitting Replacement O-Ring Chart

Fraction Size	Dash Size	SAE (Port Seal O-Ring)		ORS (Face Seal O-Ring)	
		Thread Size	O-Ring P/N	Thread Size	O-Ring P/N
1/16	1	NA	NA	NA	NA
1/8	2	5/16 - 24	NA	NA	NA
3/16	3	3/8 - 24	NA	NA	NA
1/4	4	7/16 - 20	155-760	9/16 - 18	157-037
5/16	5	1/2 - 20	NA	NA	NA
3/8	6	9/16 - 18	155-705	11/16 - 16	157-038
1/2	8	3/4 - 16	155-706	13/16 - 16	157-039
5/8	10	7/8 - 14	155-707	1 - 14	157-040
3/4	12	1-1/16 - 12	155-709	1-3/16 - 12	157-017
7/8	14	1-3/16 - 12	155-747	NA	NA
1	16	1-5/16 - 12	155-748	1-7/16 - 12	155-714
1-1/4	20	1-5/8 - 12	155-702	1-11/16 - 12	NA
1-1/2	24	1-7/8 - 12	157-001	2 - 12	NA
2	32	2-1/2 - 12	NA	NA	NA
2-1/2	40	3 - 12	NA	NA	NA
3	48	3-1/2 - 12	NA	NA	NA

Thread size indicates the diameter of the threaded area in fractions of an inch and number of threads per inch.

NA = not a current CMW part numbered o-ring, or dash size does not occur in current CMW applications

SAE = straight thread fitting that seals by sandwiching a hard o-ring between a shoulder on the male part and an angular surface at the mouth of the female port.

ORS = o-ring face seal; a type of fitting that seals by compressing a hard, captive o-ring between two flat parallel faces, one grooved for the o-ring and the other plain to act as the sealing surface



Parts Manual Change Request

(Please print clearly)

Date: _____ Dealer No. (required): _____

Your Name: _____ Position: _____

Phone: _____ Fax: _____ E-mail: _____

Publication Information:

Parts Manual No.: _____ - _____ Model: _____

Illustration Part No.:	Manual Page No.:
1. _____ - _____	1. _____
2. _____ - _____	2. _____
3. _____ - _____	3. _____

Nature of Change Request:

- Text
 Graphics
 Missing Information

Describe change requested (if possible, include copy of publication page with changes marked.):

Please fax completed form to
Parts Manual Department (580) 572-3525

Thank you for taking the time to submit this request. We will contact you if further information is needed to process your request.

**A Note To
Ditch Witch
Equipment Owners:**

If your equipment was purchased through a Ditch Witch dealer, there is no need to read further.

However, if you purchased from any other source, please fill out the form on the reverse side and return it to us.

This will enable you to receive updates on this equipment as well as information on new products of interest.

Thanks for using Ditch Witch equipment.

(Please Fold Along This Line And Seal At Bottom With Tape)



**NO POSTAGE
NECESSARY
IF MAILED
IN THE
UNITED STATES**

BUSINESS REPLY MAIL
FIRST CLASS PERMIT NO 23 PERRY OKLAHOMA

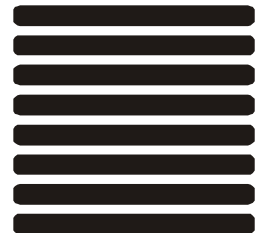

POSTAGE WILL BE PAID BY

**The Charles Machine Works, Inc.
P.O. Box 66
Perry, Oklahoma 73077-9989**



Ditch Witch® Registration Card

Please Type or Print All Information

Purchaser's Company Name

Attention

Street Address or P.O. Box

City

County

State

Zip

Nation

()

Phone Number With Area Code

Model

Serial Number

Attachments/Accessories

Serial Numbers

Attachments/Accessories

Serial Numbers

Attachments/Accessories

Serial Numbers

Name of Ditch Witch Dealership

Your Signature